

RÜCKSEITENWERKZEUGE FÜR STAR LANGDREHAUTOMATEN

BACKWORKING TOOLS FOR
STAR AUTOMATIC LATHE

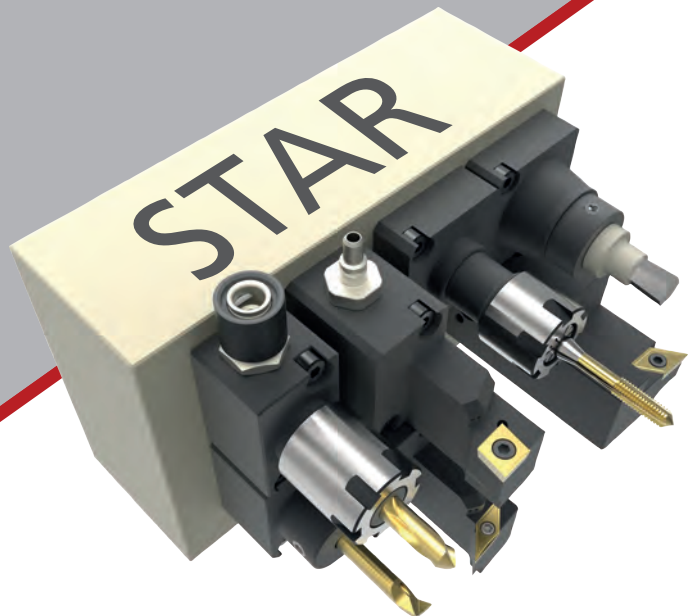

Das gesamte Werkzeugprogramm finden Sie in den folgenden Katalogen:

**Hochleistungs-Werkzeuge für Drehautomaten
Rundschaft-Werkzeuge
Höhenverstellbare Rückseitenbearbeitungs-Werkzeuge**

Bitte besuchen Sie unsere Homepage

www.Graf-Werkzeugsysteme.de

You can find the complete tool program in the following catalogs:

**High performance tooling
Round shank tools
High adjustable back working tools**

Please visit our homepage

www.Graf-Werkzeugsysteme.de

Werkzeugschlüssel/tool key

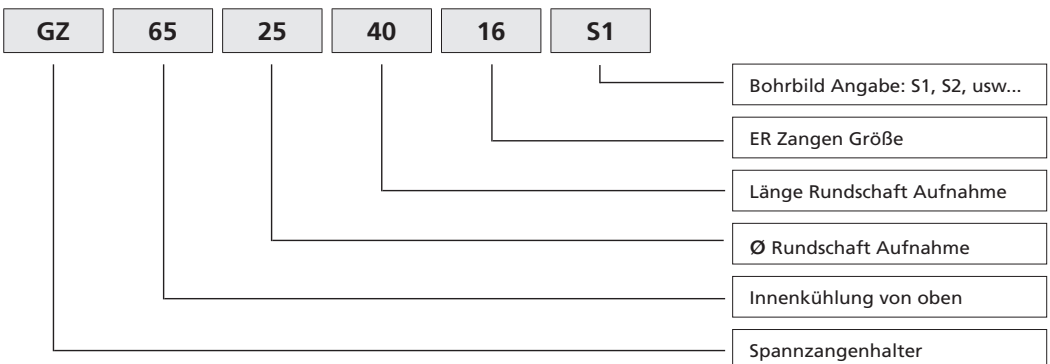
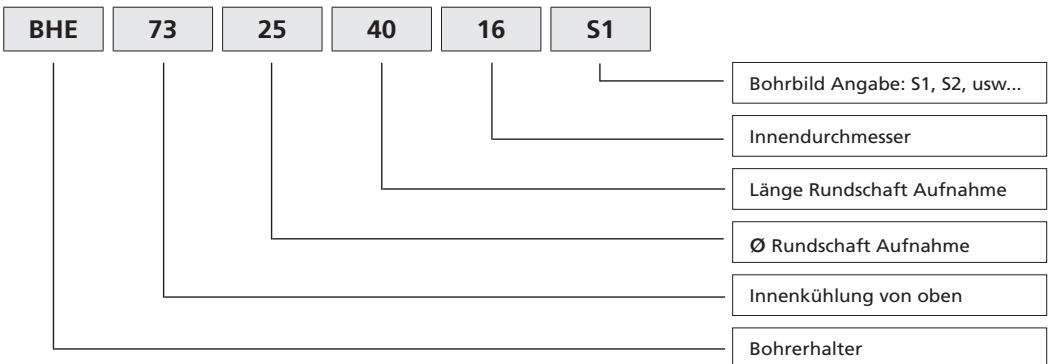
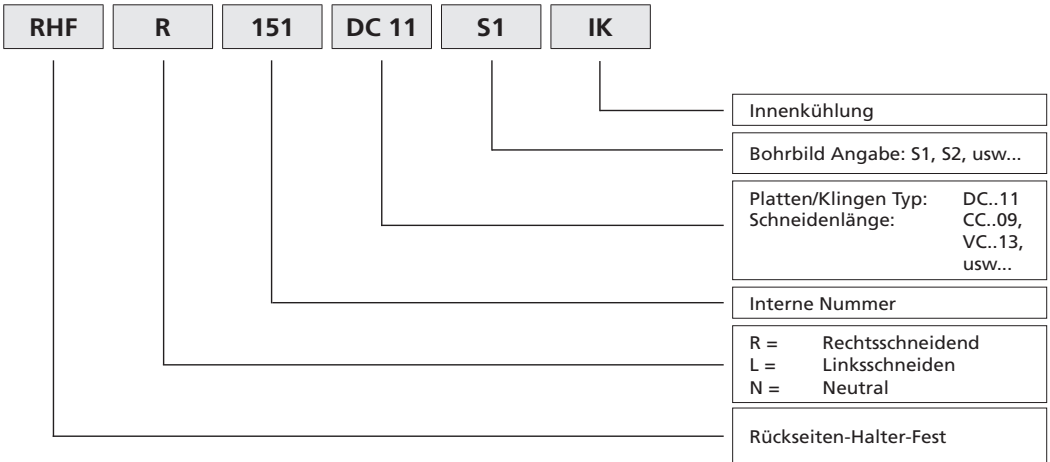

Tool key/Werkzeugschlüssel

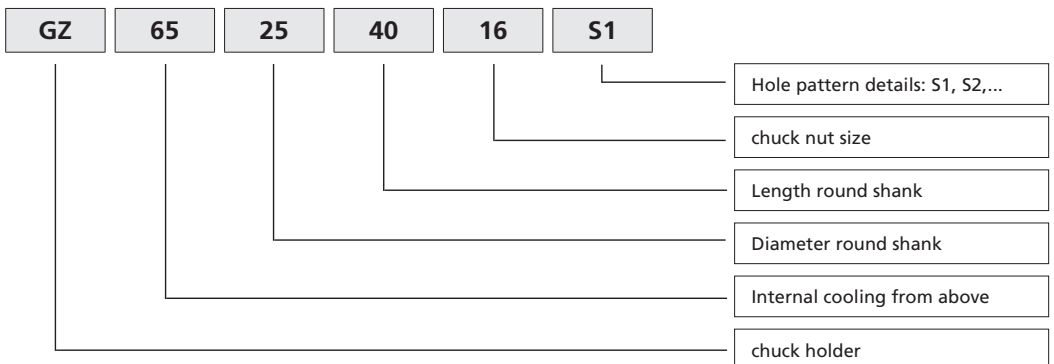
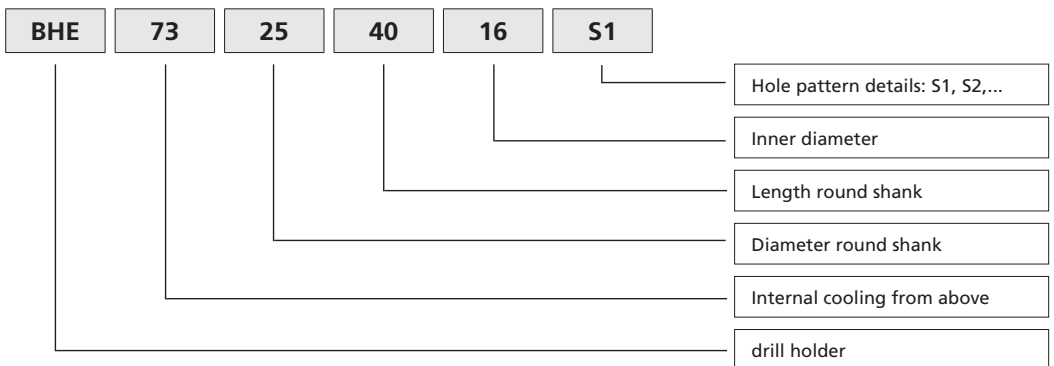
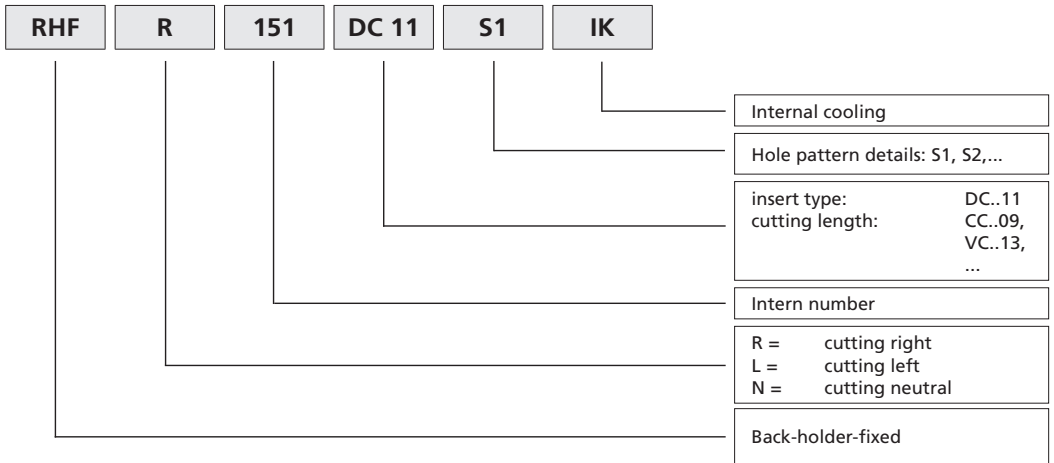

Befestigungsbeispiel Lochbild S1 - S5

Mounting example hole pattern S1 - S5

S1

- SW-20

S2

- SB-12 / 20 R
- SR-20 RIV
- SW-12 RII
- SW-20
- SR-38

S3

- ECAS-12 / 20
- SB-12 / 20 R
- SR-10J
- SR-20J / JN
- SR-20 RII / RIII / RIV
- SR-32J / JN
- SW-12 RII

S4

- ECAS-12 / 20
- SB-12 / 20 R
- SR-20J / JN
- SR-20 RII / RIII / RIV
- SR-32J / JN
- SW-20
- SV-12 / 20
- SV-32 / 32 JII
- SV-38 R

S5

- SL-7
- SL-10

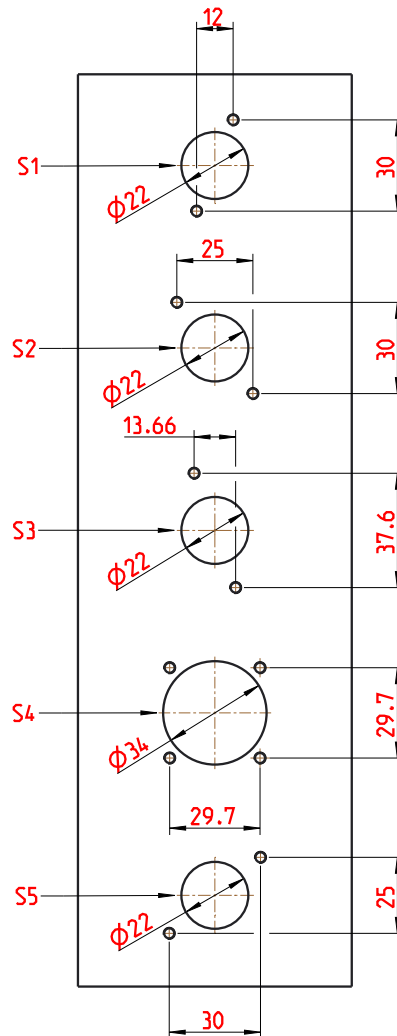

INHALTSVERZEICHNIS

SUMMARY

S1 Werkzeuge / S1 tools

Innenbearbeitung / Internal Processing

Spannzangenhalter Typ GZ 65.. Mit Innenkühlung	12
Chuck holder type GZ 65.. With coolant supply	12
Spannzangenhalter Typ GZ 51..	13
Chuck holder type GZ 51..	13
Bohrerhalter Typ BHE 73.. Mit Innenkühlung	14
Drill holder type BHE 73.. With coolant supply	14
Bohrstangenhalter Typ BS 71..	15
Boring bar holder type BS 71..	15
Bohrerhalter Typ BS 75.. Mit Innenkühlung	16
Drill holder type BS 75.. With coolant supply	16
Gewindebohrerhalter Typ GB 68.....	17
Square leaded tap holder holder type GB 68.....	17
Rückseitenhalter für HORN Schneideinsatz Typ 105.. Mit Innenkühlung	18-19
Back working holder for HORN insert type 105.. With coolant supply	18-19
Pendelhalter Typ GP 70.....	20
Floating holder type GP 70..	20

Außenbearbeitung / External Processing

Rückseitenhalter für Schneidplatte Typ DC 11.. Mit Innenkühlung	21
Back working holder for insert type DC 11.. With coolant supply	21
Rückseitenhalter für Schneidplatte Typ VC 11.. Mit Innenkühlung	22-25
Back working holder for insert type VC 11.. With coolant supply	22-25
Rückseitenhalter für Schneidplatte Typ VC 13.. Mit Innenkühlung	26
Back working holder for insert type VC 13.. With coolant supply	26
Rückseitenhalter für Schneidplatte Typ CC 09 T3.. Mit Innenkühlung	27-28
Back working holder for insert type CC 09 T3.. With coolant supply	27-28
Rückseitenhalter für Schneidplatte Typ YW 11.. Mit Innenkühlung	29
Back working holder for insert type YW 11.. With coolant supply	29
Rückseitenhalter für Schneidplatte Typ 16 ER/EL.. Mit Innenkühlung	30
Back working holder for insert type 16 ER/EL.. With coolant supply	30
Rückseitenhalter für Schneidplatte Typ GRAF G.0004.. Mit Innenkühlung.....	31
Back working holder for insert type GRAF G.0004.. With coolant supply.....	31
Rückseitenhalter für Schneidplatte Typ HORN S274.. Mit Innenkühlung	32
Back working holder for insert type HORN S274.. With coolant supply	32
Rückseitenhalter für Schneidplatte Typ PRECI 615..Mit Innenkühlung	33
Back working holder for insert type PRECI 615.. With coolant supply	33
Rückseitenhalter für Vierkantschaft	34
Back working holder for square shank.....	34
Gewindeschneideisenhalter Typ TYP GS 69.....	35
Screw threading holder type GS 69..	35
Zwischenstück.....	36-37
Zwischenstück.....	36-37

INHALTSVERZEICHNIS

SUMMARY

S2 Werkzeuge / S2 tools

Innenbearbeitung / Internal Processing

Spannzangenhalter Typ GZ 65.. Mit Innenkühlung	38
Chuck holder type GZ 65.. With coolant supply	38
Spannzangenhalter Typ GZ 51..	39
Chuck holder type GZ 65..	39
Bohrhalter Typ BHE 73.. Mit Innenkühlung.....	40
Drill holder type BHE 73.. With coolant supply	40
Bohrstangenhalter Typ BS 71..	41
Boring bar holder type BS 71..	41
Bohrstangenhalter Typ BS 75.. Mit Innenkühlung	42
Boring bar holder type BS 75.. With coolant supply	42
Gewindebohrerhalter Typ GB 68.....	43
Square leaded tap holder holder type GB 68.....	43
Rückseitenhalter für HORN Schneideinsatz Typ 105.. Mit Innenkühlung	44-46
Back working holder for HORN insert type 105.. With coolant supply	44-46
Pendelhalter Typ GP 70.....	47
Floating holder type GP 70..	47
Mehrkant-Drückgerät GDF 76.....	48
Multi-sided equipment GDF 76..	48

Außenbearbeitung / External Processing

Rückseitenhalter für Schneidplatte Typ DC 07.. Mit Innenkühlung	49-50
Back working holder for insert type DC 07.. With coolant supply	49-50
Rückseitenhalter für Schneidplatte Typ DC 11.. Mit Innenkühlung.....	51-54
Back working holder for insert type DC 11.. With coolant supply	51-54
Rückseitenhalter für Schneidplatte Typ CC 06.. Mit Innenkühlung	55
Back working holder for insert type CC 06.. With coolant supply	55
Rückseitenhalter für Schneidplatte Typ CC 09.. Mit Innenkühlung	56-57
Back working holder for insert type CC 09.. With coolant supply	56-57
Rückseitenhalter für Schneidplatte Typ VC 07.. Mit Innenkühlung	58
Back working holder for insert type VC 07.. With coolant supply	58
Rückseitenhalter für Schneidplatte Typ VC 11..	59-60
Back working holder for insert type VC 11..	59-60
Rückseitenhalter für Schneidplatte Typ VC 11.. Mit Innenkühlung	61-63
Back working holder for insert type VC 11.. With coolant supply	61-63
Rückseitenhalter für Schneidplatte Typ VC 13.. Mit Innenkühlung.....	64-65
Back working holder for insert type VC 13.. With coolant supply	64-65
Rückseitenhalter für Schneidplatte Typ VC 16.. Mit Innenkühlung.....	66
Back working holder for insert type VC 16.. With coolant supply	66
Rückseitenhalter für Schneidplatte Typ VP 10.. Mit Innenkühlung	67
Back working holder for insert type VP 10.. With coolant supply	67
Rückseitenhalter für Schneidplatte Typ VP 11.. Mit Innenkühlung	68
Back working holder for insert type VP 11.. With coolant supply	68
Rückseitenhalter für Schneidplatte Typ TC 11.. Mit Innenkühlung	69
Back working holder for insert type TC 11.. With coolant supply	69
Rückseitenhalter für Schneidplatte Typ YW 11.. Mit Innenkühlung	70
Back working holder for insert type YW 11.. With coolant supply	70

INHALTSVERZEICHNIS

SUMMARY

Rückseitenhalter für Schneidplatte Typ 16 ER/EL.. Mit Innenkühlung	71
Back working holder for insert type 16 ER/EL.. With coolant supply	71
Rückseitenhalter für Schneidplatte Typ GRAF G.0004.. Mit Innenkühlung.....	72
Back working holder for insert type GRAF G.0004.. With coolant supply.....	72
Rückseitenhalter für Schneidplatte Typ HORN S274.. Mit Innenkühlung	73
Back working holder for insert type HORN S274.. With coolant supply	73
Rückseitenhalter für Schneidplatte Typ HORN S312.. Mit Innenkühlung	74-75
Back working holder for insert type HORN S312.. With coolant supply	74-75
Rückseitenhalter für Schneidplatte Typ HORN S315.. Mit Innenkühlung	76
Back working holder for insert type HORN S315.. With coolant supply	76
Rückseitenhalter für Schneidplatte Typ CS/SCD/TPCS/UPCS Mit Innenkühlung	77
Back working holder for insert type CS/SCD/TPCS/UPCS With coolant supply	77
Rückseitenhalter für Schneidplatte Typ PRECI 615.. Mit Innenkühlung	78
Back working holder for insert type PRECI 615.. With coolant supply	78
Rückseitenhalter für Schneidplatte Typ QER 12.. Mit Innenkühlung	79
Back working holder for insert type QER 12.. With coolant supply	79
Rückseitenhalter für Vierkantschaft	80
Back working holder for square shank.....	80
Gewindeschneideisenhalter Typ TYP GS 69.....	81
Screw threading holder type GS 69..	81
Zwischenstück.....	82-83
Plate between	82-83
Kühlmittelbrücke für STAR S2 Halter.....	84
Coolant bridge for STAR S2 holder	84

INHALTSVERZEICHNIS
SUMMARY

S3 Werkzeuge / S3 tools

Innenbearbeitung / Internal Processing

Spannzangenhalter Typ GZ 65.. Mit Innenkühlung	85-86
Back working chuck holder type GZ 65.. With coolant supply.....	85-86
Spannzangenhalter Typ GZ 51..	87
Chuck holder type GZ 65..	87
Bohrstangenhalter Typ BS 71..	88
Boring bar holder type BS 71..	88
Bohrerhalter Typ BHE 73.. Mit Innenkühlung	89
DRILL holder type BHE 73.. With coolant supply	89
Gewindebohrerhalter Typ GB 68.....	90
Square leaded tap holder holder type GB 68.....	90
Rückseitenhalter für HORN Schneideinsatz Typ 105.. Mit Innenkühlung	91-92
Back working holder for HORN insert type 105.. With coolant supply	91-92
Pendelhalter Typ GP 70.....	93
Floating holder type GP 70.....	93
Mehrkant-Drückgerät GDF 76.....	94
Multi-sided equipment GDF 76..	94

Außenbearbeitung / External Processing

Rückseitenhalter für Schneidplatte Typ YW 11.. Mit Innenkühlung	95
Back working holder for insert type YW 11.. With coolant supply	95
Gewindeschneideisenhalter Typ TYP GS 69.....	96
Screw threading holder type GS 69..	96
Zwischenstück.....	97-98
Plate between	97-98

INHALTSVERZEICHNIS

SUMMARY

S4 Werkzeuge / S4 tools

Innenbearbeitung / Internal Processing

Spannzangenhalter Typ GZ 65.. Mit Innenkühlung	99
Chuck holder type GZ 65.. With coolant supply	99
Bohrerhalter Typ BHE 73.. Mit Innenkühlung	100
Drill holder type BHE 73.. With coolant supply	100
Rückseitenhalter für HORN Schneideinsatz Typ 105.. Mit Innenkühlung	101-102
Back working holder for HORN insert type 105.. With coolant supply	101-102
Rückseitenhalter für HORN Schneideinsatz Typ 110.. Mit Innenkühlung	103
Rückseitenhalter für HORN Schneideinsatz Typ 110.. Mit Innenkühlung	103

Außenbearbeitung / External Processing

Rückseitenhalter für Schneidplatte Typ DC 11.. Mit Innenkühlung	104-105
Back working holder for insert type DC 11.. With coolant supply	104-105
Rückseitenhalter für Schneidplatte Typ VC 11.. Mit Innenkühlung	106-107
Back working holder for insert type VC 11.. With coolant supply	106-107
Rückseitenhalter für Schneidplatte Typ YW 11.. Mit Innenkühlung	108
Back working holder for insert type YW 11.. With coolant supply	108
Rückseitenhalter für Schneidplatte Typ CC 09.. Mit Innenkühlung	109
Back working holder for insert type CC 09.. With coolant supply	109
Rückseitenhalter für Schneidplatte Typ GRAF G.0004.. Mit Innenkühlung	110
Back working holder for insert type GRAF G.0004.. With coolant supply	110
Rückseitenhalter für Schneidplatte Typ HORN S274.. Mit Innenkühlung	111-112
Back working holder for insert type HORN S274.. With coolant supply	111-112
Rückseitenhalter für Schneidplatte Typ 16 ER/EL.. Mit Innenkühlung	113
Back working holder for insert type 16 ER/EL.. With coolant supply	113
Rückseitenhalter für Vierkantschaft	114
Back working holder for square shank	114

S5 Werkzeuge / S5 tools

Außenbearbeitung / External Processing

Rückseitenhalter für Schneidplatte Typ DC 07.. Mit Innenkühlung	115
Back working holder for insert type DC 07.. With coolant supply	115
Rückseitenhalter für Schneidplatte Typ YW 11.. Mit Innenkühlung	116
Back working holder for insert type YW 11.. With coolant supply	116
Rückseitenhalter für Schneidplatte Typ 16 ER/EL.. Mit Innenkühlung	117
Back working holder for insert type 16 ER/EL.. With coolant supply	117

INHALTSVERZEICHNIS
SUMMARY

Dreifach Rückseitenhalter / triple backworking holder

Dreifach Rückseitenhalter für STAR Maschinen	118-120
Triple backworking holder for STAR machine	118-120

Wendeplattenhalter für Dreifach Rückseitenhalter	121-123
Turret plate holder for triple backworking holder	121-123

Größenzuordnung Spannkeil für HORN 105.....	124
Sizing wedge for HORN 105.....	124

Berechnung des Steigungswinkel β	125-126
Calculation the helix angles β	125-126

Spannzangenhalter Typ GZ 65.. Chuck holder type GZ 65..

Lochbild S1
hole pattern S1

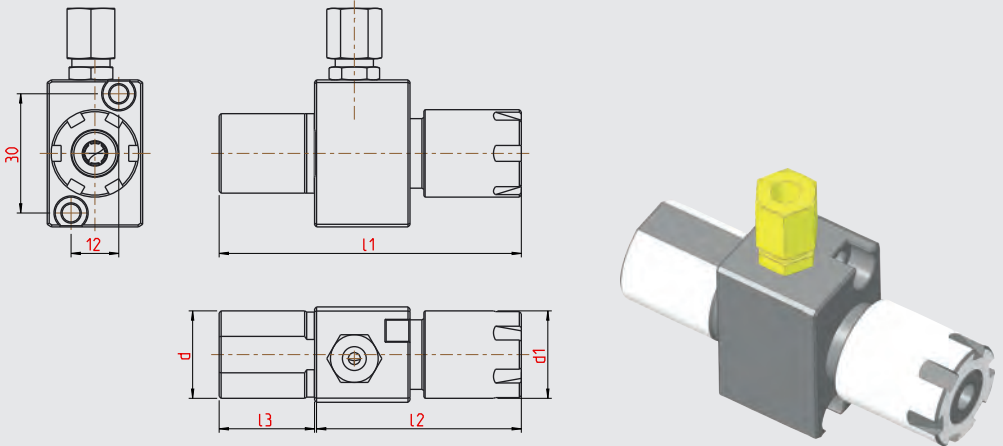

Art. Nummer Art. Number	Bezeichnung Description	d	l1	l2	l3	d1	für Spannzange for collet
12-1121	GZ65.2224.16.S1	22	76	52	24	22	ER16

Abmessungen in mm
Dimensions in mm

Hinweis/Note:

IK Anschluss oben und unten
coolant connection at the top and down

Ersatzteile / Spare parts

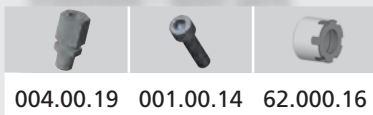

004.00.19 001.00.14 62.000.16

Abdichtbare Spannmutter muß separat bestellt werden
Sealed chucking nut must be ordered separately

Spannzangenhalter Typ GZ 51..
Chuck holder type GZ 51..

Lochbild S1
hole pattern S1

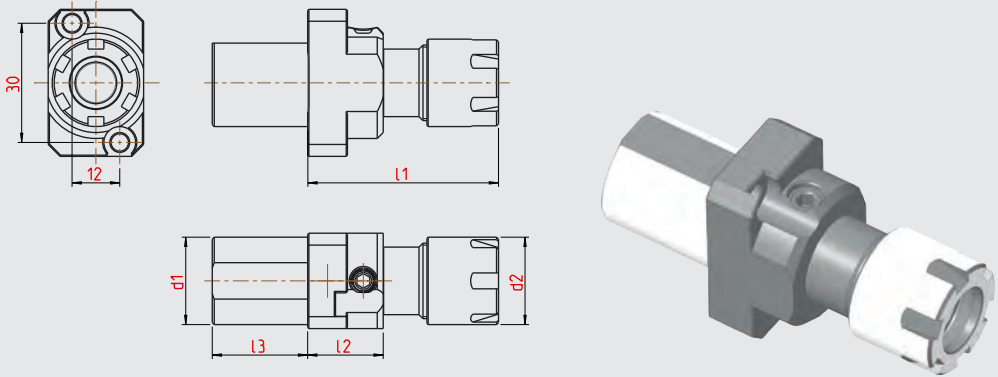

Art. Nummer Art. Number	Bezeichnung Description	d	l _{min}	l _{max}	l2	d2	für Spannzeuge for collet
11-3221	GZ51.2224.11.S1	22	38	58	24	16	ER11
11-3225	GZ51.2224.16.S1	22	48	68	24	22	ER16

Abmessungen in mm
Dimensions in mm

Hinweis/Note:

max. Auszug 7mm
max. excerpt is 7mm

Ersatzteile / Spare parts

Art.-Nr:		
11-3221	001.00.66	62.000.11
11-3225	001.00.66	62.000.16

Bohrerhalter Typ BHE 73.. Drill holder type BHE 73..

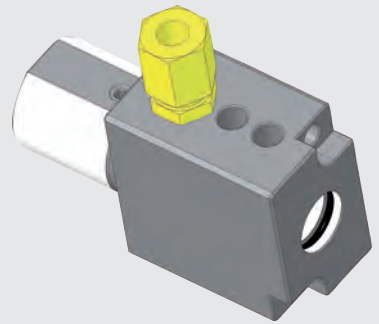
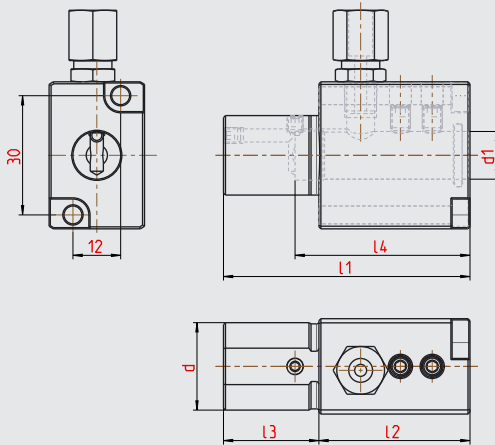

Lochbild S1 hole pattern S1



Art. Nummer Art. Number	Bezeichnung Description	d	d1	l1	l2	l3	l4
12-1189	BHE73.2224.06.S1	22	6	62	38	24	42
12-1115	BHE73.2224.08.S1	22	8	62	38	24	42
12-1116	BHE73.2224.10.S1	22	10	62	38	24	44
12-1117	BHE73.2224.12.S1	22	12	62	38	24	44
12-1130	BHE73.2224.16.S1	22	16	62	38	24	40

Abmessungen in mm
Dimensions in mm

Ersatzteile / Spare parts

Art.-Nr			
12-1189			002.00.175
12-1115			002.00.111
12-1116	004.00.19	001.01.108	20.010.101
12-1117			002.00.109
12-1130			002.00.103

Hinweis/Note:

IK Anschluss oben und unten
coolant connection at the top and down

Bohrstangenhalter Typ BS 71..
Boring bar holder type BS 71..

Lochbild S1
hole pattern S1

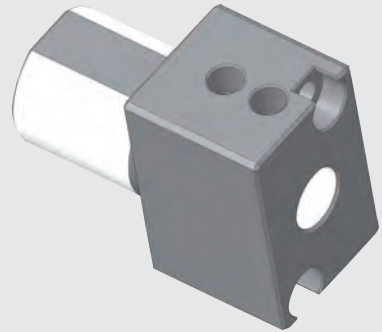
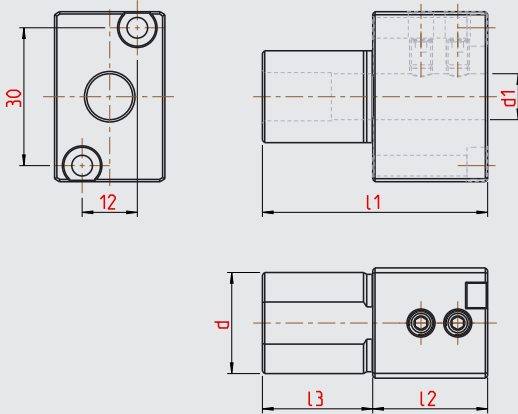

Art. Nummer Art. Number	Bezeichnung Description	d	d1	l1	l2	l3
12-1119	BS71.2224.10.S1	22	10	62	38	24
12-1118	BS71.2224.16.S1	22	16	44	20	24

Abmessungen in mm
Dimensions in mm

Hinweis/Note:

ohne IK
no internal cooling

Ersatzteile / Spare parts

Art.-Nr:	
12-1119	001.01.142
12-1118	001.00.19

Bohrstangenhalter Typ BS 75.. Boring bar holder type BS 75..

Lochbild S1
hole pattern S1

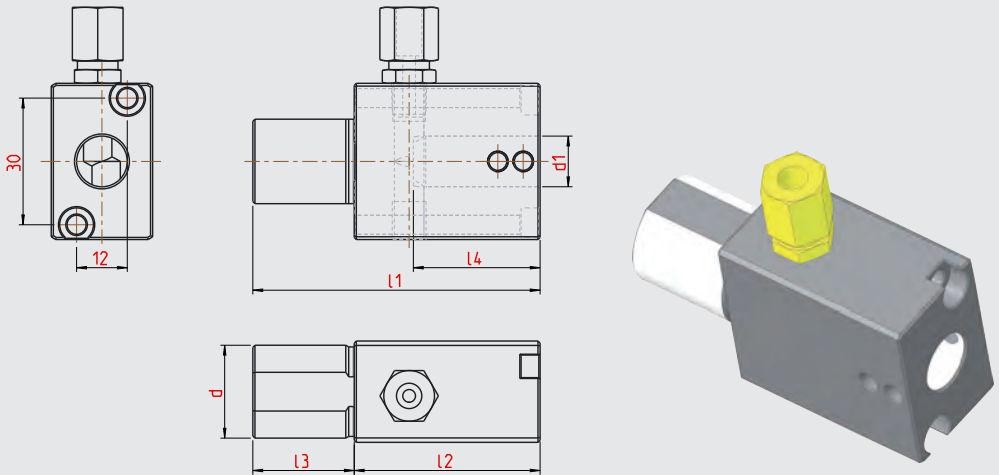

Art. Nummer Art. Number	Bezeichnung Description	d	d1	l1	l2	l3	l4	für Reduzierhülsen for reduction sleeves
12-1120	BS75.2224.12.S1	22	12	68	44	24	30	RH... 12...

Abmessungen in mm
Dimensions in mm

Hinweis/Note:

IK Anschluss oben und unten
coolant connection at the top and down

Ersatzteile / Spare parts



Reduzierhülsen für Bohrstangenhalter Typ Picco
Adapter sleeve for boring bar holder type Picco
Douille de Réduction pour porte outil type Picco

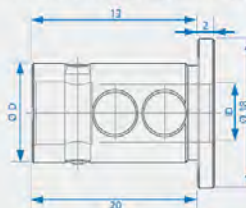

Bestell-Nr.	D	ID
RH 12 0420	12	4
RH 12 0520	12	5
RH 12 0620	12	6
RH 12 0720	12	7
RH 12 0820	12	8

Gewindebohrerhalter Typ GB 68..
Square leded tap holder type GB 68..

Lochbild S1
hole pattern S1

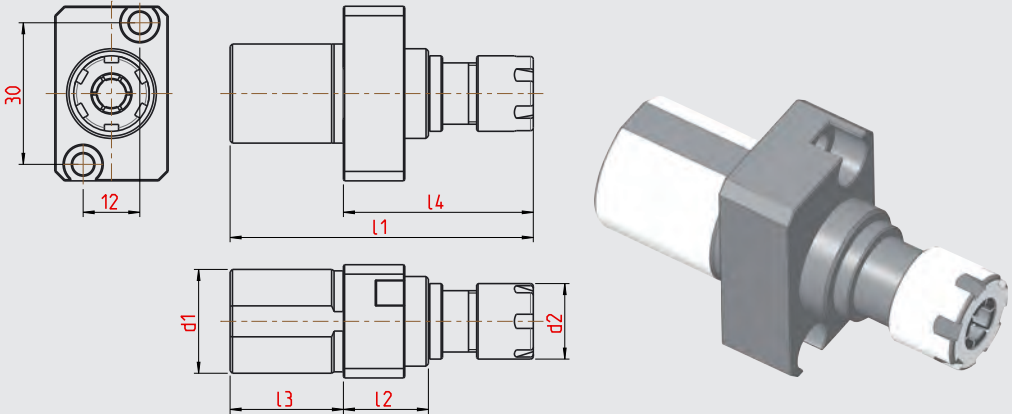

Art. Nummer Art. Number	Bezeichnung Description	d	l1	l2	l3	l4	d2	für Spannzange for collet
11-0393	GB68.2224.11.S1	22	64	18	24	40	16	ER11
11-0395	GB68.2224.16.S1	22	74	18	24	50	22	ER16

Abmessungen in mm
Dimensions in mm

Hinweis/Note:

max. Auszug 7mm
max. excerpt is 7mm

Ersatzteile / Spare parts

Art.-Nr:		
12-0393	6200011	001.00.66
12-0395	6200016	001.00.66

Rückseitenhalter für HORN Schneideinsatz Typ 105

Back working holder HORN insert type 105

Lochbild S1
hole pattern S1

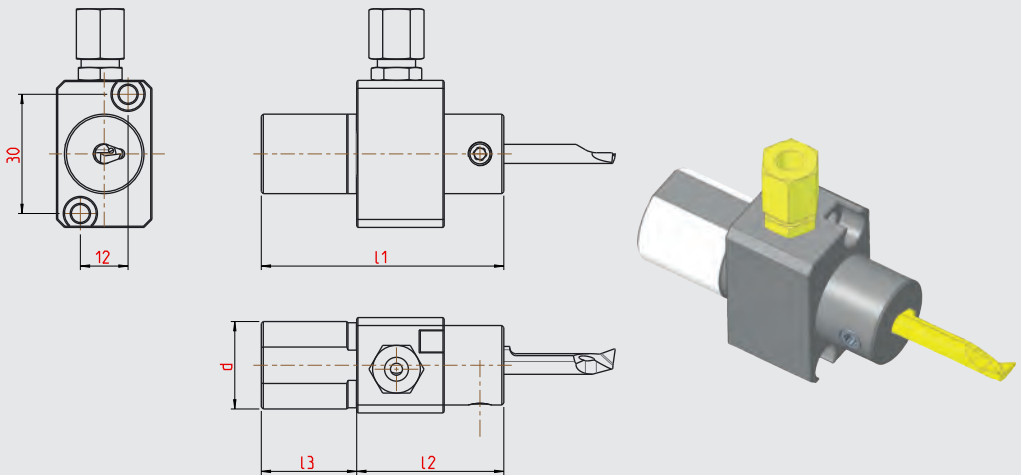



Art. Nummer Art. Number	Bezeichnung Description	d	l1	l2	l3	für Schneideinsatz for insert
12-1057	RHF.N.145.H105.S1.IK	22	61	37	24	Horn Typ 105
12-1318	RHF.N.200.H105.S1.IK	22	76	52	24	Horn Typ 105

Abmessungen in mm
Dimensions in mm

Hinweis/Note:

IK Anschluss oben und unten
coolant connection at the top and down

Ersatzteile / Spare parts

Art.-Nr:			
12-1057	001.01.36	004.00.19	001.00.19
12-1318	001.01.36	004.00.19	001.00.09

Rückseitenhalter für HORN Schneideinsatz Typ 105 Back working holder HORN insert type 105

Lochbild S1
hole pattern S1

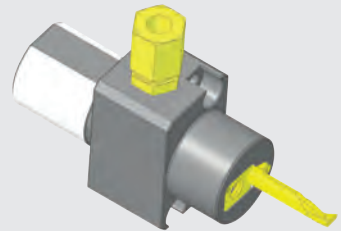
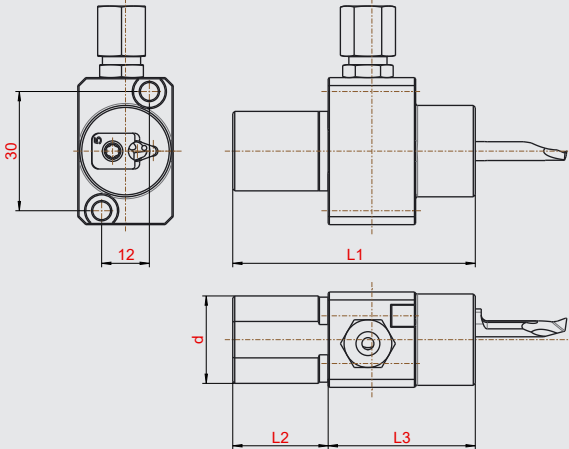

Art. Nummer Art. Number	Bezeichnung Description	d	l1	l2	l3	für Schneideinsatz for insert
12-1571	RHF.N.281.S.H105.S1.IK.03	22	61	24	37	Horn Typ 105, Größe 03
12-1572	RHF.N.281.S.H105.S1.IK.04	22	61	24	37	Horn Typ 105, Größe 04
12-1573	RHF.N.281.S.H105.S1.IK.05	22	61	24	37	Horn Typ 105, Größe 05
12-1575	RHF.N.282.S.H105.S1.IK.03	22	76	24	52	Horn Typ 105, Größe 03
12-1576	RHF.N.282.S.H105.S1.IK.04	22	76	24	52	Horn Typ 105, Größe 04
12-1577	RHF.N.282.S.H105.S1.IK.05	22	76	24	52	Horn Typ 105, Größe 05

Abmessungen in mm
Dimensions in mm

Hinweis/Note:

Zur Bestimmung der Keilgröße, entnehmen Sie die Maße „b“ aus den HORN-Katalogen
To determine the wedge size, refer to the dimensions „b“ in the HORN catalogues

Ersatzteile / Spare parts

			
004.00.19	002.00.170	001.00.19	435203/4/5
004.00.19	002.00.170	001.00.19	435203/4/5

Pendelhalter Floating holder

Lochbild S1 hole pattern S1

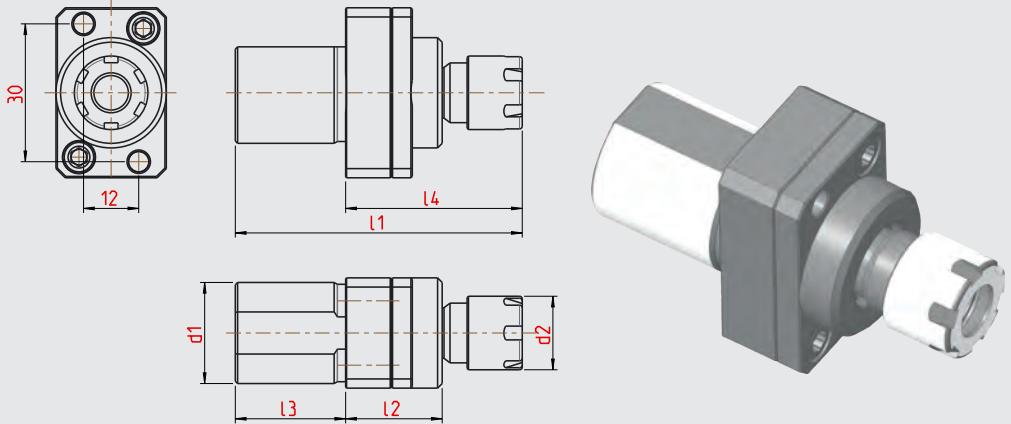

Art. Nummer Art. Number	Bezeichnung Description	d	l1	l2	l3	l4	d2	für Spannzange for collet
11-3228	GP70.2224.11.S1	22	62,5	21	24	38,5	16	ER11

Abmessungen in mm
Dimensions in mm

Ersatzteile / Spare parts



62.000.11 001.00.19

Rückseitenhalter für Schneidplatte Typ DC..11..
Back working holder for insert type DC..11..

Lochbild S1
hole pattern S1

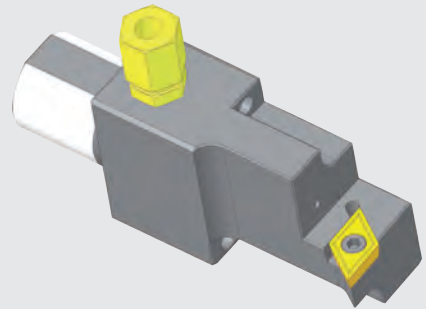
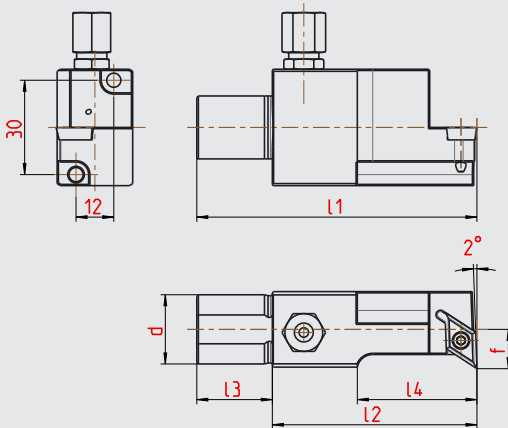

Ausführung rechtsschneidend, wie dargestellt · right cutting version as shown

Art. Nummer Art. Number	Bezeichnung Description	d	l1	l2	l3	l4	f	für Schneidplatte for insert
12-1090	RHF.R.146.DC11.S1.IK	22	89	65	24	38	125	DC... 11...
12-1089	RHF.L.146.DC11.S1.IK	22	89	65	24	38	125	DC... 11...

Abmessungen in mm
Dimensions in mm

Hinweis/Note:

IK Anschluss oben und unten
coolant connection at the top and down

Ersatzteile / Spare parts

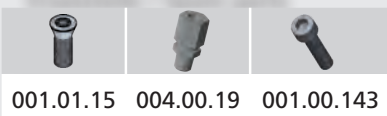

Rückseitenhalter für Schneidplatte Typ VC..11.. Back working holder for insert type VC..11..

Lochbild S1
hole pattern S1

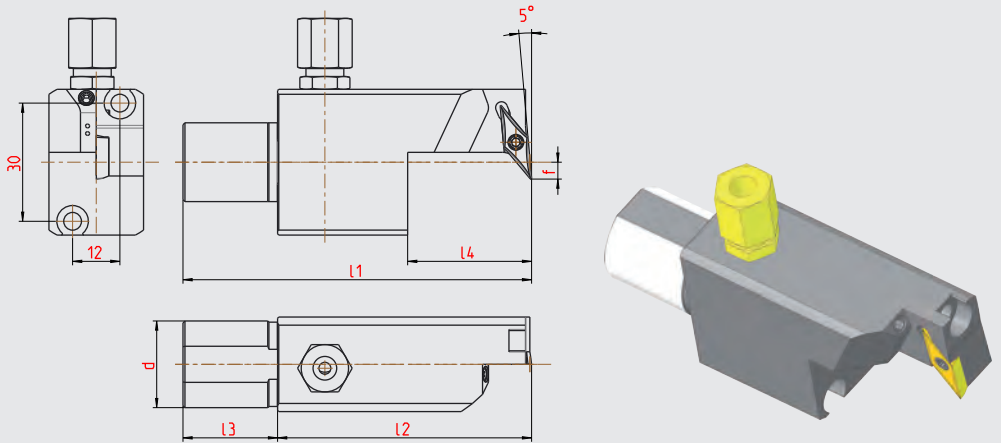

Ausführung rechtsschneidend, wie dargestellt · right cutting version as shown

Art. Nummer Art. Number	Bezeichnung Description	d	l1	l2	l3	f	l4	für Schneidplatte for insert
12-1059	RHFR.147.VC11.S1.IK	22	89	65	24	4,3	31	VC... 11...

Abmessungen in mm
Dimensions in mm

Hinweis/Note:

IK Anschluss oben und unten
coolant connection at the top and down

Ersatzteile / Spare parts

		
001.01.08 S2	004.00.19	001.00.143
		001.00.146

Rückseitenhalter für Schneidplatte Typ VC..11..
Back working holder for insert type VC..11..

Lochbild S1
hole pattern S1

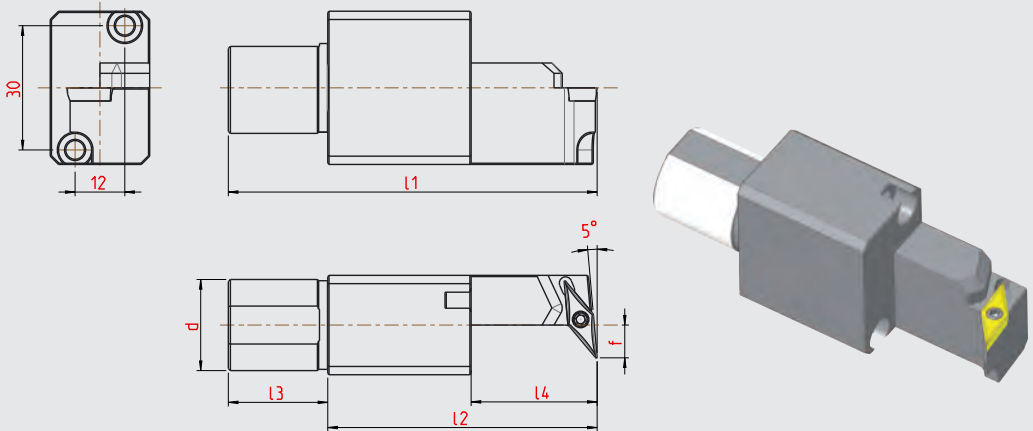

Ausführung rechtsschneidend, wie dargestellt · right cutting version as shown

Art. Nummer Art. Number	Bezeichnung Description	d	l1	l2	l3	f	l4	für Schneidplatte for insert
12-1056	RHF.R.108.VC11.S1	22	89	65	24	8	30	VC... 11...
12-1065	RHF.L.108.VC11.S1	22	89	65	24	8	30	VC... 11...

Abmessungen in mm
Dimensions in mm

Hinweis/Note:

ohne IK
no internal cooling

Ersatzteile / Spare parts

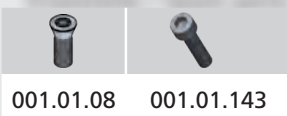

Rückseitenhalter für Schneidplatte Typ VC.. 11.. Back working holder for insert type VC.. 11..

Lochbild S1
hole pattern S1

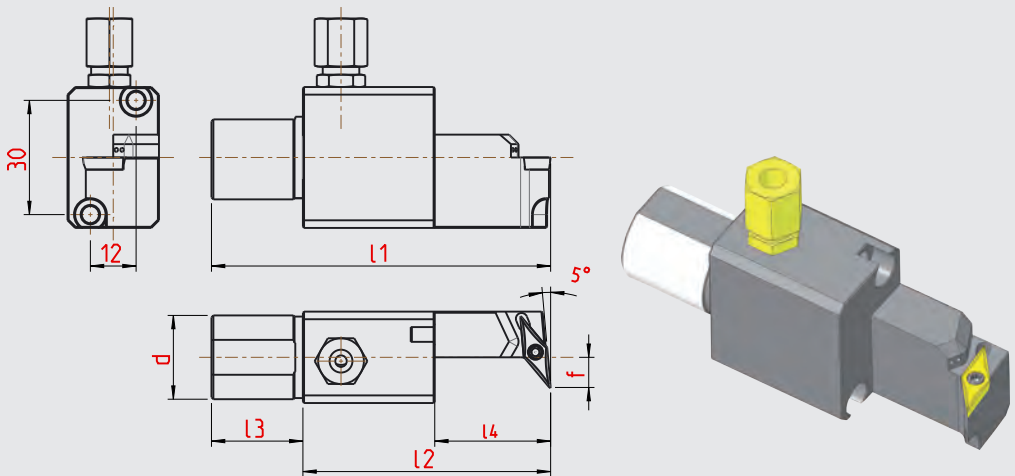

Ausführung rechtsschneidend, wie dargestellt · right cutting version as shown

Art. Nummer Art. Number	Bezeichnung Description	d	l1	l2	l3	f	l4	für Schneidplatte for insert
12-1168	RHF.R.108.VC11.S1.IK	22	89	65	24	8	30	VC.. 11 03..
12-1191	RHF.L.108.VC11.S1.IK	22	89	65	24	8	30	VC.. 11 03..

Abmessungen in mm
Dimensions in mm

Hinweis/Note:

IK Anschluss oben und unten
coolant connection at the top and down

Ersatzteile / Spare parts



Rückseitenhalter für Schneidplatte VC.. 11..
Back working holder for insert type VC.. 11..

Lochbild S1
hole pattern S1

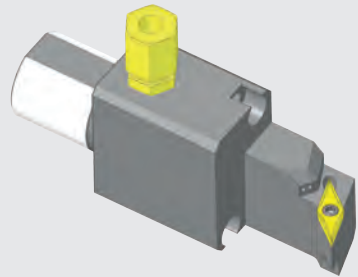
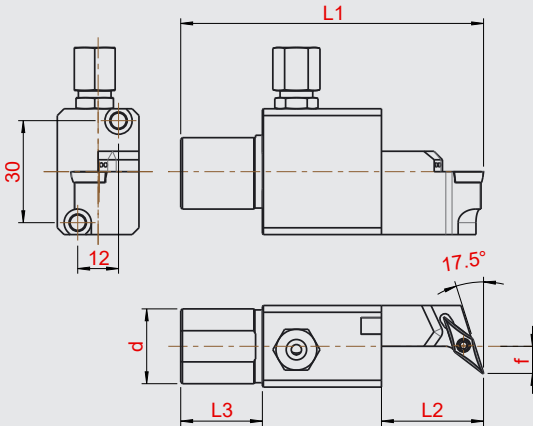

Ausführung rechtsschneidend, wie dargestellt · right cutting version as shown



Art. Nummer Art. Number	Bezeichnung Description	d	I1	I2	I3	f	für Schneidplatte for insert
12-1424	RHF.R.240.VC11.S1.IK	22	89	30	24	8	VC.. 11..
12-1425	RHF.L.240.VC11.S1.IK	22	89	30	24	8	VC.. 11..

Abmessungen in mm
Dimensions in mm

Hinweis/Note:

IK Anschluss oben und unten
coolant connection at the top and down

Ersatzteile / Spare parts

		
004.00.19	002.00.168	001.01.08
	002.00.170	

Rückseitenhalter für Schneidplatte Typ VC..13.. Back working holder for insert type VC..13..

Lochbild S1
hole pattern S1

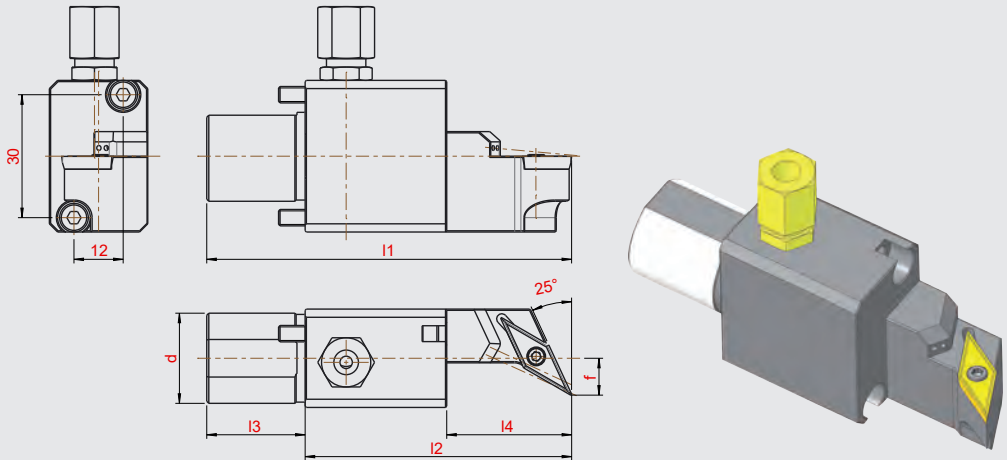

Ausführung rechtsschneidend, wie dargestellt · right cutting version as shown

Art. Nummer Art. Number	Bezeichnung Description	d	l1	l2	l3	f	l4	für Schneidplatte for insert
12-1315	RHF.R.198.VC13.S1.IK	22	89	65	24	9	30	VC... 13.03...
12-1379	RHF.L.198.VC13.S1.IK	22	89	65	24	9	30	VC... 13.03...

Abmessungen in mm
Dimensions in mm

Hinweis/Note:

IK Anschluss oben und unten
coolant connection at the top and down

Ersatzteile / Spare parts

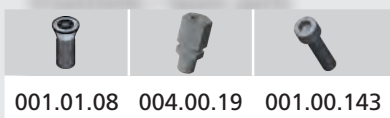

001.01.08 004.00.19 001.00.143

Rückseitenhalter für Schneidplatte Typ CC..09 T3..
Back working holder for insert type CC..09 T3..

Lochbild S1
hole pattern S1

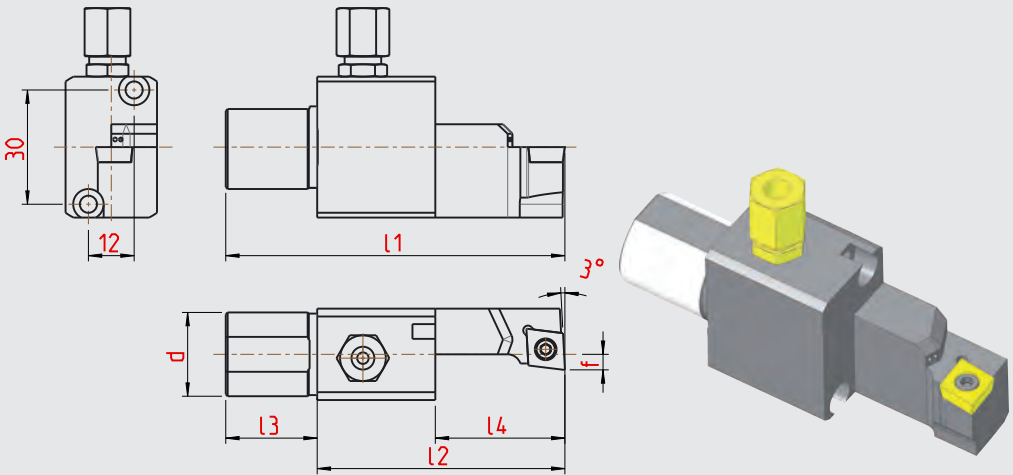

Ausführung rechtsschneidend, wie dargestellt · right cutting version as shown

Art. Nummer Art. Number	Bezeichnung Description	d	l1	l2	l3	f	l4	für Schneidplatte for insert
12-1169	RHF.R.142.CC09.S1.IK	22	89	65	24	4,1	34	CC... 09 T3...
12-1192	RHF.L.142.CC09.S1.IK	22	89	65	24	4,1	34	CC... 09 T3...

Abmessungen in mm
Dimensions in mm

Hinweis/Note:

IK Anschluss oben und unten
coolant connection at the top and down

Ersatzteile / Spare parts

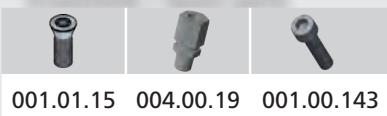

001.01.15 004.00.19 001.00.143

Rückseitenhalter für Schneidplatte Typ CC..09 T3.. Back working holder for insert type CC..09 T3..

Lochbild S1
hole pattern S1

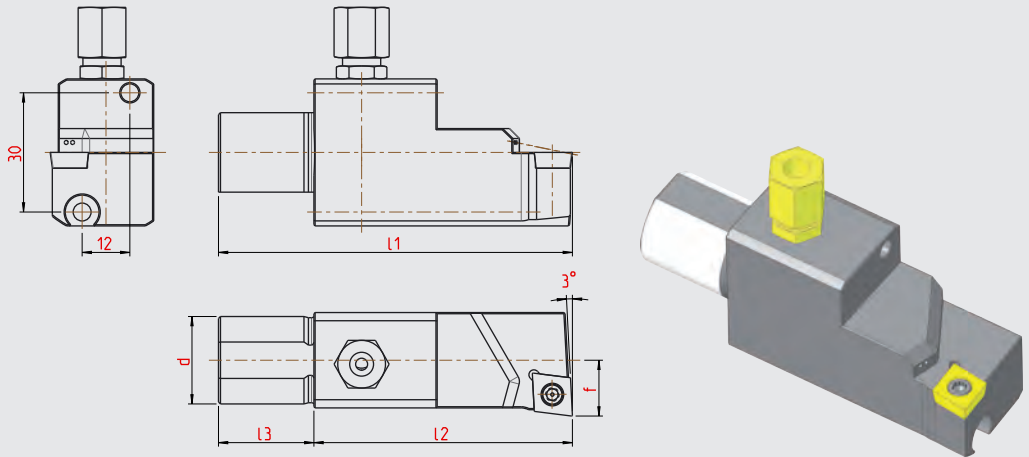

Ausführung rechtsschneidend, wie dargestellt · right cutting version as shown



Art. Nummer Art. Number	Bezeichnung Description	d	l1	l2	l3	f	für Schneidplatte for insert
12-1274	RHF.R.188.CC09.S1.IK	22	89	65	24	14	CC... 09 T3...
12-1275	RHF.L.188.CC09.S1.IK	22	89	65	24	14	CC... 09 T3...

Abmessungen in mm
Dimensions in mm

Hinweis/Note:

IK Anschluss oben und unten
coolant connection at the top and down

Ersatzteile / Spare parts

		
001.01.15	004.00.19	001.00.143
		001.00.145

Rückseitenhalter für Schneidplatte YW.. 11..
Back working holder for insert type YW.. 11..

Lochbild S1
hole pattern S1

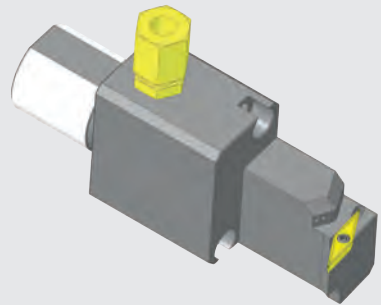
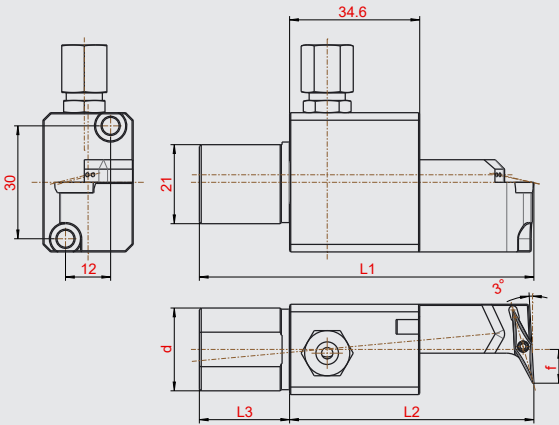

Ausführung rechtsschneidend, wie dargestellt · right cutting version as shown





Art. Nummer Art. Number	Bezeichnung Description	d	l1	l2	l3	f	für Schneidplatte for insert
12-1605	RHF.R.289.YW11.S1.IK	22	89	65	24	9	YW.. 11..
12-1606	RHF.L.289.YW11.S1.IK	22	89	65	24	9	YW.. 11..

Abmessungen in mm
Dimensions in mm

Hinweis/Note:

IK Anschluss oben und unten
coolant connection at the top and down

Ersatzteile / Spare parts

			
004.00.19	002.00.168	001.01.25	001.00.143
	002.00.170		

Rückseitenhalter für Schneidplatte Typ 16 ER/EL.. Back working holder for insert type 16 ER/EL..

Lochbild S1
hole pattern S1

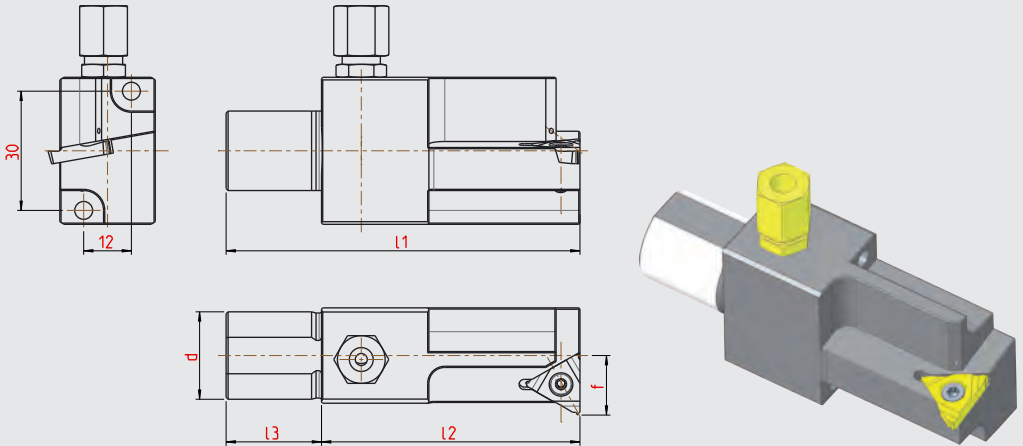

Ausführung rechtsschneidend, wie dargestellt · right cutting version as shown

Art. Nummer Art. Number	Bezeichnung Description	d	l1	l2	l3	f	für Schneidplatte for insert
12-1088	RHF.R.149.16ER.S1.IK	22	89	65	24	15	16ER
12-1087	RHF.L.149.16EL.S1.IK	22	89	65	24	15	16EL

Abmessungen in mm
Dimensions in mm

Hinweis/Note:

IK Anschluss oben und unten
coolant connection at the top and down

Ersatzteile / Spare parts

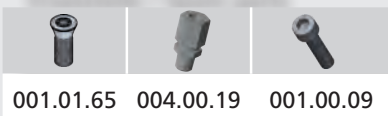

Berechnung Steigungswinkel
auf Seite 125-126.
Calculation helix angles on page 125-126.

Rückseitenhalter für Schneidplatte Typ GRAF G.0004..
Back working holder for insert type GRAF G.0004..

Lochbild S1
hole pattern S1

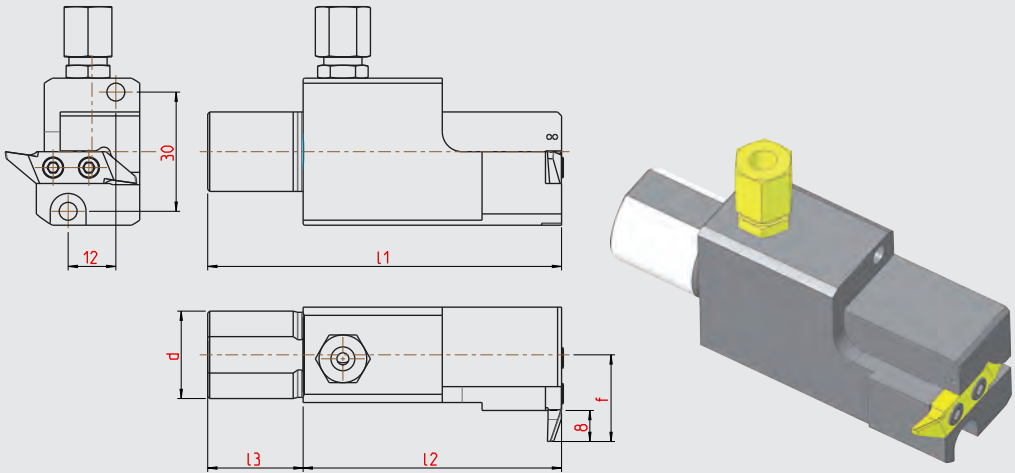

Ausführung rechtsschneidend, wie dargestellt · right cutting version as shown



Art. Nummer Art. Number	Bezeichnung Description	d	l1	l2	l3	f	für Schneidplatte for insert
12-1258	RHF.R.186.G0004.S1.IK	22	89	65	24	22	GRAF G.0004
12-1259	RHF.L.186.G0004.S1.IK	22	89	65	24	22	GRAF G.0004

Abmessungen in mm
Dimensions in mm

Hinweis/Note:

IK Anschluss oben und unten
coolant connection at the top and down

Ersatzteile / Spare parts

		
001.01.15	004.00.19	001.00.108
		001.00.146

Rückseitenhalter für Schneidplatte Typ HORN S274.. Back working holder for insert type HORN S274..

Lochbild S1 hole pattern S1

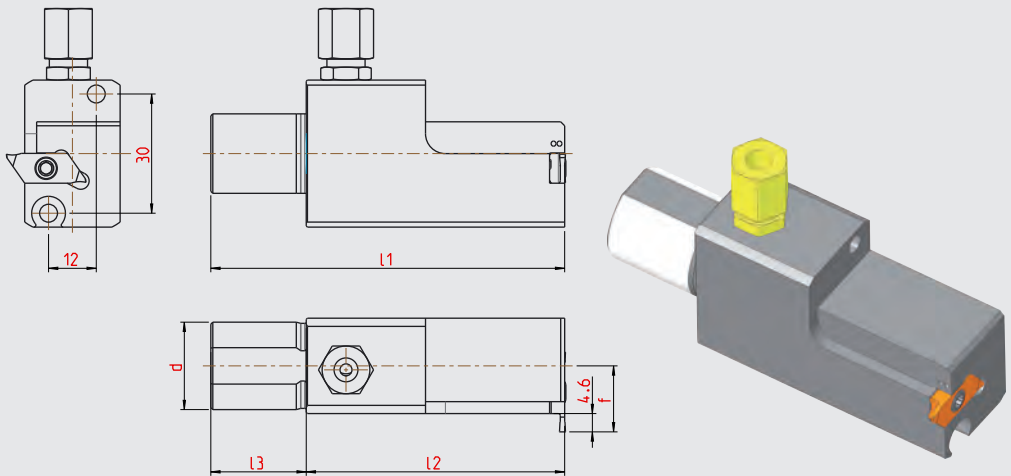

Ausführung rechtsschneidend, wie dargestellt · right cutting version as shown



Art. Nummer Art. Number	Bezeichnung Description	d	l1	l2	l3	f	für Schneidplatte for insert
12-1260	RHF.R.187.S274.S1.IK	22	89	65	24	16,5	Horn Typ S274
12-1261	RHF.L.187.S274.S1.IK	22	89	65	24	16,5	Horn Typ S274

Abmessungen in mm
Dimensions in mm

Hinweis/Note:

IK Anschluss oben und unten
coolant connection at the top and down

Ersatzteile / Spare parts

		
001.01.39	004.00.19	001.00.143
		001.00.146

Rückseitenhalter für Schneidplatte Typ PRECI 615..
Back working holder for insert type PRECI 615..

Lochbild S1
hole pattern S1

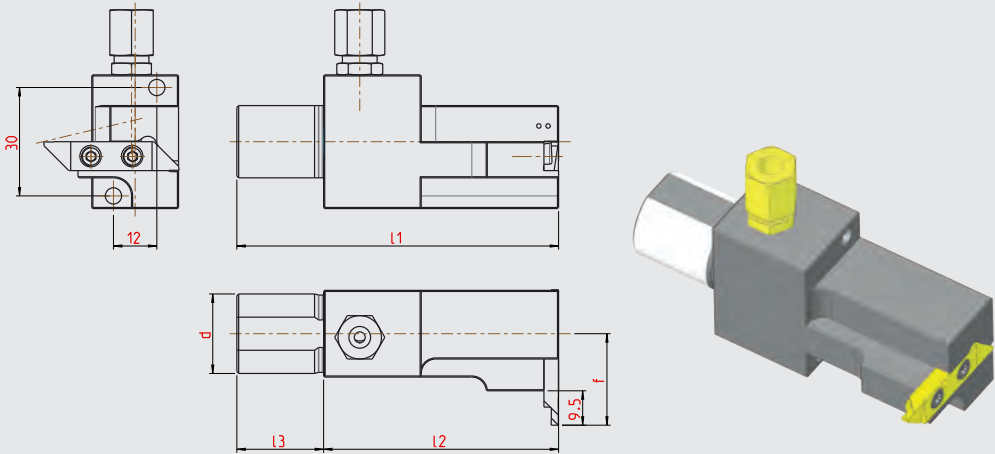

Ausführung rechtsschneidend, wie dargestellt · right cutting version as shown



Art. Nummer Art. Number	Bezeichnung Description	d	l1	l2	l3	f	für Schneidplatte for insert
12-1091	RHF.R.148.P615.S1.IK	22	89	65	24	25,3	PRECI 615..
12-1028	RHF.L.148.P615.S1.IK	22	89	65	24	25,3	PRECI 615..

Abmessungen in mm
Dimensions in mm

Hinweis/Note:

IK Anschluss oben und unten
coolant connection at the top and down

Ersatzteile / Spare parts

		
004.00.19	002.00.168	001.01.15
	002.00.170	

Rückseitenhalter für Vierkantschaft Back working holder for square shank

Lochbild S1 hole pattern S1

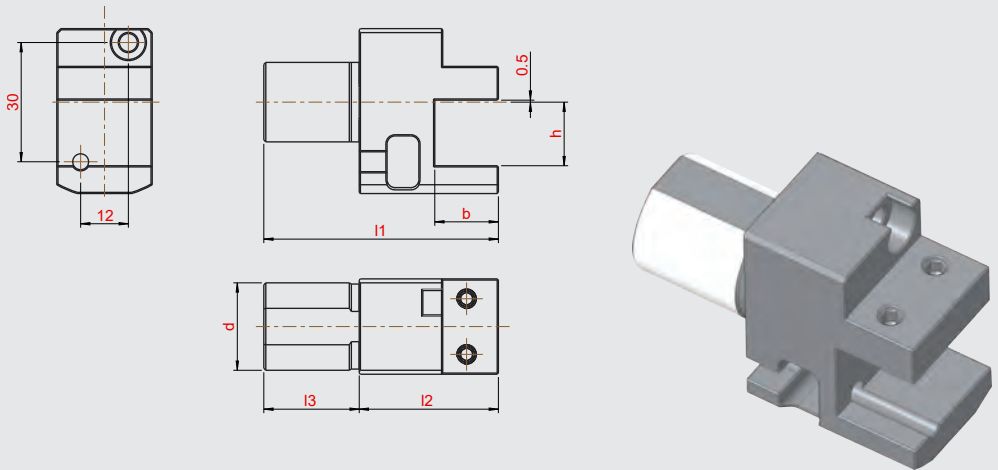

Art. Nummer Art. Number	Bezeichnung Description	d	l1	l2	l3	b	h
12-1322	RHF.N.202.1212.S1	22	59	35	24	12	12
12-1321	RHF.N.202.1616.S1	22	59	35	24	16	16

Abmessungen in mm
Dimensions in mm

Ersatzteile / Spare parts

	
001.01.24	001.00.09
001.01.24	001.00.66

Gewindeschneideisenhalter Typ GS 69..
Screw threading holder type GS 69..

Lochbild S1
hole pattern S1

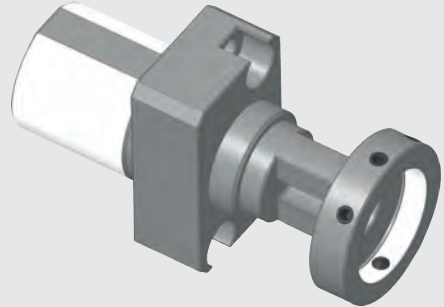
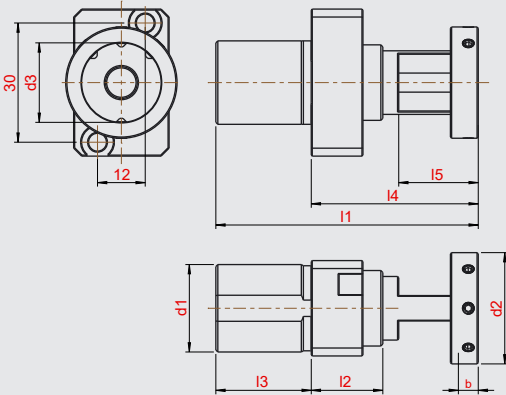

Art. Nummer Art. Number	Bezeichnung Description	d	l1	l2	l3	l4	l5	d2	d3	b
11-0400	GS69.2224.S1.1620	22	67	18	24	43	21	24	16	5
11-0397	GS69.2224.S1.2020	22	67	18	24	43	21	28	20	6
11-0402	GS69.2224.S1.2030	22	77	19	24	53	31	28	20	6

Abmessungen in mm
Dimensions in mm

Hinweis/Note:

max. Auszug 7mm
max. excerpt is 7mm

Ersatzteile / Spare parts



002.00.48

001.00.66

Zwischenstück Plate between

Lochbild S1
hole pattern S1

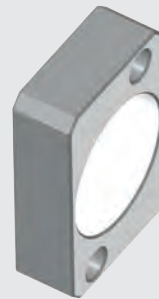
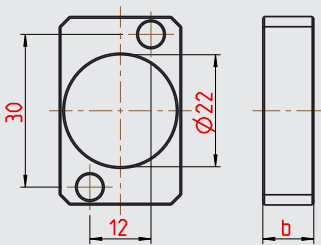

Art. Nummer Art. Number	Bezeichnung Description	b
12-1378	Z 2,5 S1	2,5
12-0550	Z 5 S1	5
12-0551	Z 10 S1	10
12-0552	Z 15 S1	15

Abmessungen in mm
Dimensions in mm

Hinweis/Note:

Zwischenstücke für Bohrbild S1
plate between for hole pattern S1

Zwischenstück
Plate between

Lochbild S1
hole pattern S1

Hinweis/Note:

Anwendung von Zwischenstücken
application from plate between

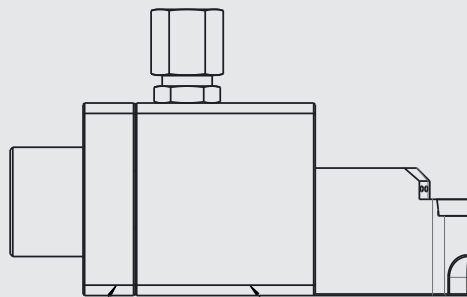
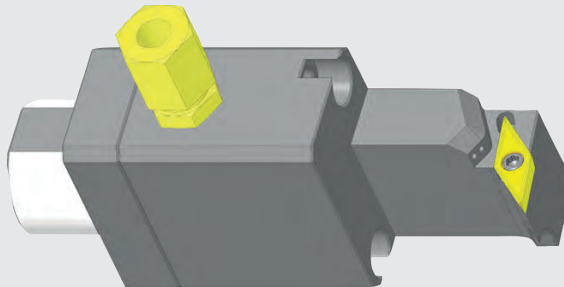

Zwischenstück Z ... S1
plate between Z.. S1

Einsatz RHF
holder RHF

Spannzangenhalter Typ GZ 65.. Holder type GZ 65..

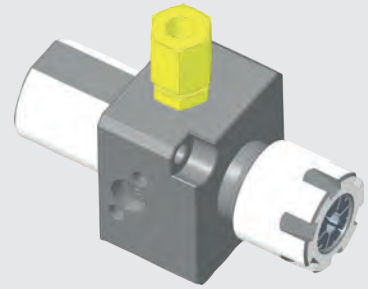
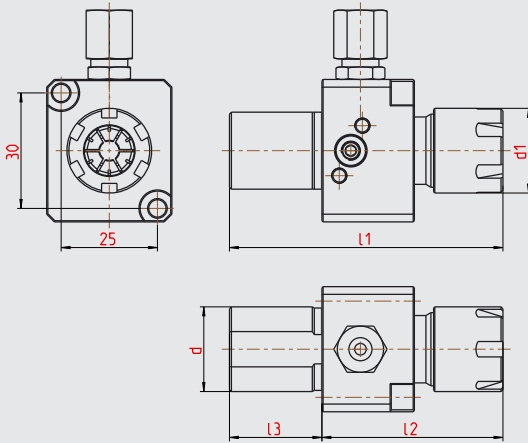

Lochbild S2
hole pattern S2



Art. Nummer Art. Number	Bezeichnung Description	d	l1	l2	l3	d1	für Spannzange for collet
12-1108	GZ65.2224.16.S2	22	76	52	24	22	ER16
12-1198	GZ65.2224.20.S2	22	78	54	24	28	ER20
12-1293	GZ65.2224.25.S2	22	86	62	24	35	ER25

Abmessungen in mm
Dimensions in mm

Ersatzteile / Spare parts

Art.-Nr:			
12-1108	004.00.19	001.00.142	62.00.16
12-1198	004.00.19	001.00.142	62.00.20
12-1293	004.00.19	001.00.142	62.000.25

Hinweis/Note:

IK Anschluss oben und unten
coolant connection at the top and down

Abdichtbare Spannmutter
muß separat bestellt werden
Sealed chucking nut
must be ordered separately

Spannzangenhalter Typ GZ 51..
Chuck holder type GZ 51..

Lochbild S2
hole pattern S2

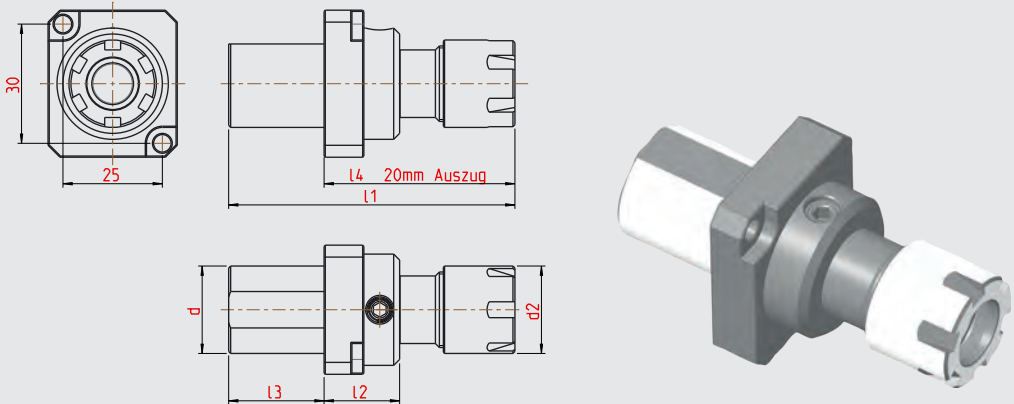

Art. Nummer Art. Number	Bezeichnung Description	d	l _{min}	l _{max}	l2	d2	für Spannzeuge for collet
11-3223	GZ51.2224.11.S2	22	39	59	25	16	ER11
11-3227	GZ51.2224.16.S2	22	48	68	19	22	ER16

Abmessungen in mm
Dimensions in mm

Hinweis/Note:

Spannzangenhalter mit Längenverstellung, max. Auszug 20 mm
chuck holder with length adjustment, max. excerpt is 20mm

Ersatzteile / Spare parts

Art.-Nr:		
11-3223	001.00.66	62.000.11
11-3227	001.00.66	62.000.16

Bohrerhalter Typ BHE 73.. Drill holder type BHE 73..

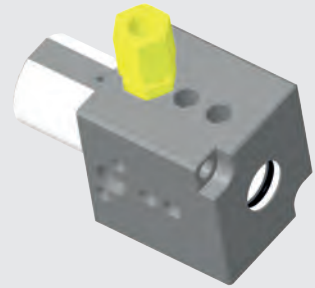
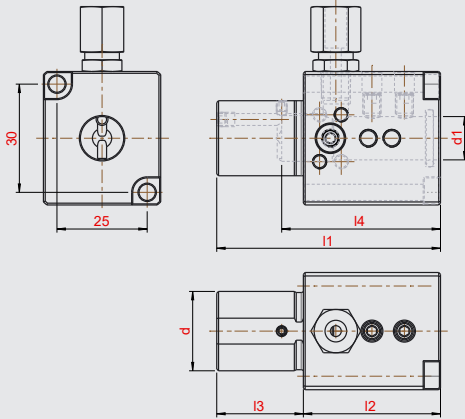

Lochbild S2
hole pattern S2



Art. Nummer Art. Number	Bezeichnung Description	d	d1	l1	l2	l3	l4
12-1495	BHE73.2224.04.S2	22	4	62	38	24	25
12-1253	BHE73.2224.06.S2	22	6	62	38	24	36
12-1112	BHE73.2224.08.S2	22	8	62	38	24	42
12-1113	BHE73.2224.10.S2	22	10	62	38	24	40
12-1214	BHE73.2224.12.S2	22	12	62	38	24	44
12-1215	BHE73.2224.16.S2	22	16	62	41	24	48

Abmessungen in mm
Dimensions in mm

Ersatzteile / Spare parts

Art.-Nr			
12-1495		001.00.19	
12-1253		001.00.108	002.00.175
12-1112	004.00.19	001.00.108	002.00.111
12-1113		001.00.108	002.00.101
12-1214		001.00.108	002.00.109
12-1115		001.00.109	002.00.103

Bohrstangenhalter Typ BS 71..
Boring bar holder type BS 71..

Lochbild S2
hole pattern S2

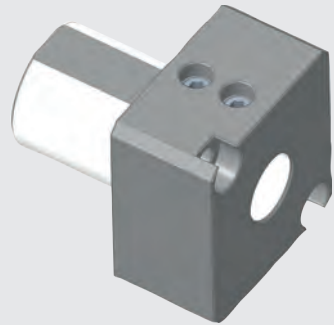
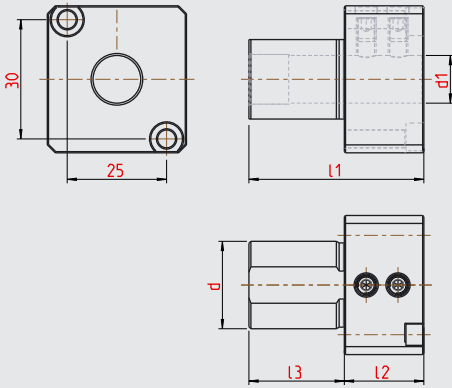

Art. Nummer Art. Number	Bezeichnung Description	d	d1	l1	l2	l3
12-1111	BS71.2224.10.S2	22	10	45	21	24
12-1122	BS71.2224.12.S2	22	12	44	20	24
12-1110	BS71.2224.16.S2	22	16	44	20	24

Abmessungen in mm
Dimensions in mm

Hinweis/Note:
ohne IK
no internal cooling

Ersatzteile / Spare parts



001.00.19

Bohrstangenhalter Typ BS 75.. Boring bar holder type BS 75..

Lochbild S2
hole pattern S2

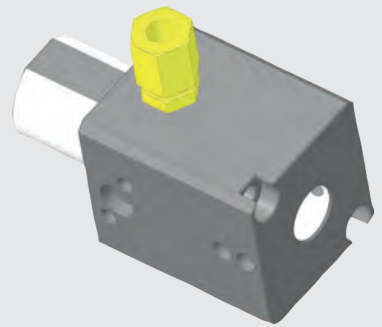
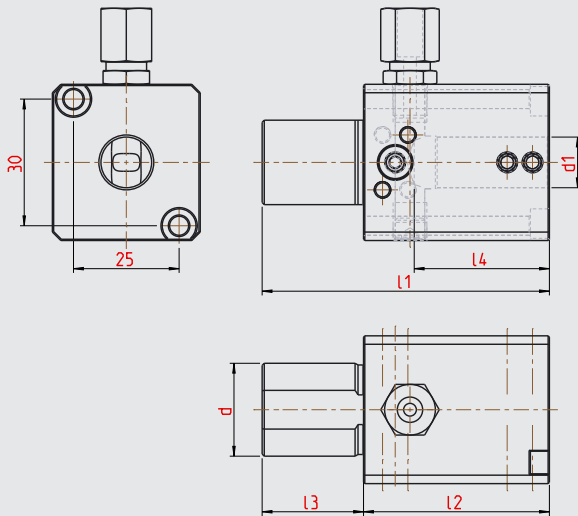

Art. Nummer Art. Number	Bezeichnung Description	d	d1	l1	l2	l3	l4	für Reduzierhülsen for reduction sleeves
12-1109	BS75.2224.12.S2	22	12	68	44	24	32	RH... 12...

Abmessungen in mm
Dimensions in mm

Hinweis/Note:

IK Anschluss oben und unten
coolant connection at the top and down

Ersatzteile / Spare parts

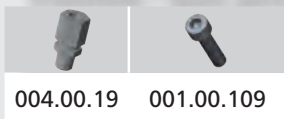

004.00.19 001.00.109

Reduzierhülsen für Bohrstangenhalter Typ Picco
Adapter sleeve for boring bar holder type Picco
Douille de Réduction pour porte outil type Picco

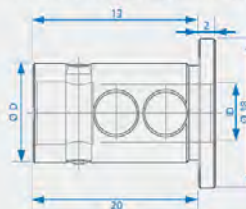

Bestell-Nr.	D	ID
RH 12 0420	12	4
RH 12 0520	12	5
RH 12 0620	12	6
RH 12 0720	12	7
RH 12 0820	12	8

Gewindebohrerhalter Typ GB 68..
Square leaded tap holder type GB 68..

Lochbild S2
hole pattern S2

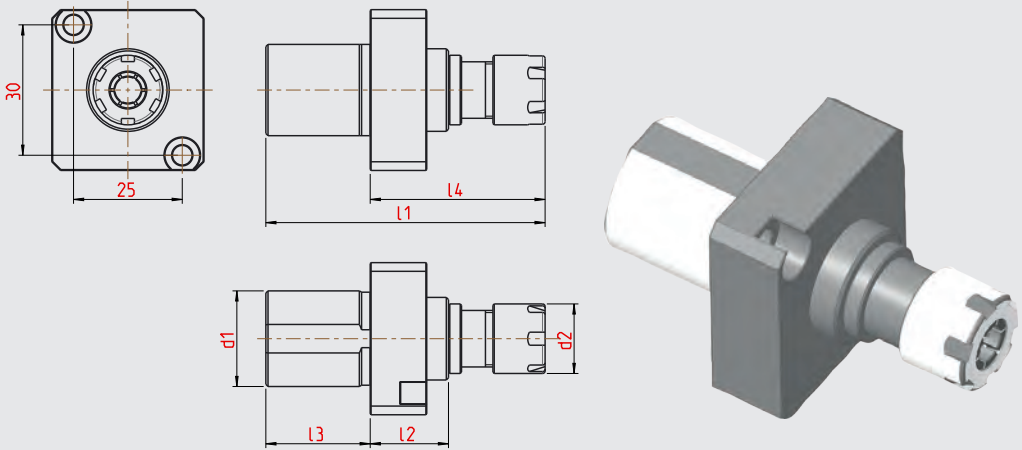

Art. Nummer Art. Number	Bezeichnung Description	d	l1	l2	l3	l4	d2	für Spannzange for cutting insert
11-0390	GB68.2224.11.S2	22	64	18	24	40	16	ER11
11-0391	GB68.2224.16.S2	22	74	18	24	50	22	ER16

Abmessungen in mm
Dimensions in mm

Hinweis/Note:

max. Auszug 7mm
max. excerpt is 7mm

Ersatzteile / Spare parts

Art.-Nr:		
12-0390	6200011	001.00.66
12-0391	6200016	001.00.66

Rückseitenhalter für HORN Schneideinsatz Typ 105.. Back working holder HORN insert type 105..

Lochbild S2
hole pattern S2

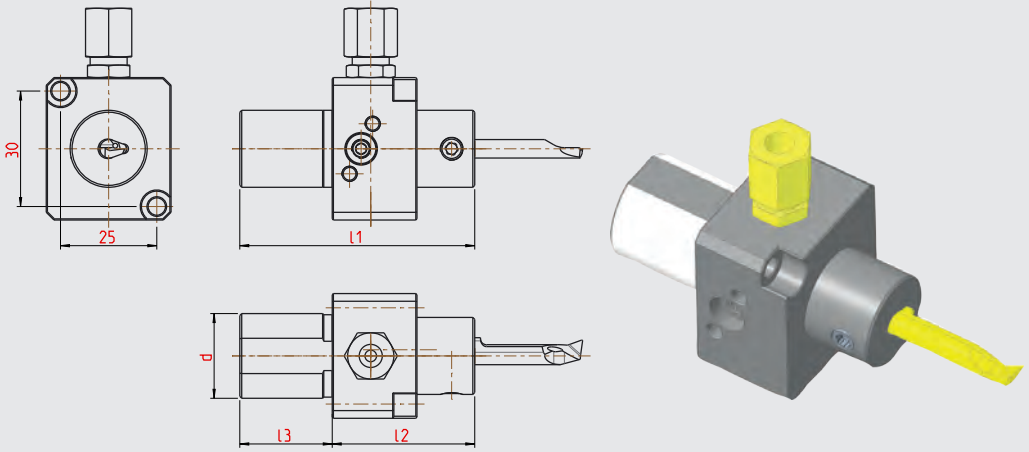



Art. Nummer Art. Number	Bezeichnung Description	d	l1	l2	l3	für Schneideinsatz for insert
12-1092	RHF.N.151.H105.S2.IK	22	61	37	24	Horn Typ 105
12-1136	RHF.N.152.H105.S2.IK	22	76	52	24	Horn Typ 105

Abmessungen in mm
Dimensions in mm

Hinweis/Note:

IK Anschluss oben und unten
coolant connection at the top and down

Ersatzteile / Spare parts

Art.-Nr:			
12-1092	001.01.36	004.00.19	001.00.19
12-1036	001.01.36	004.00.19	001.00.142

Rückseitenhalter für HORN Schneideinsatz Typ 105..

Back working holder HORN insert type 105..

Lochbild S2
hole pattern S2

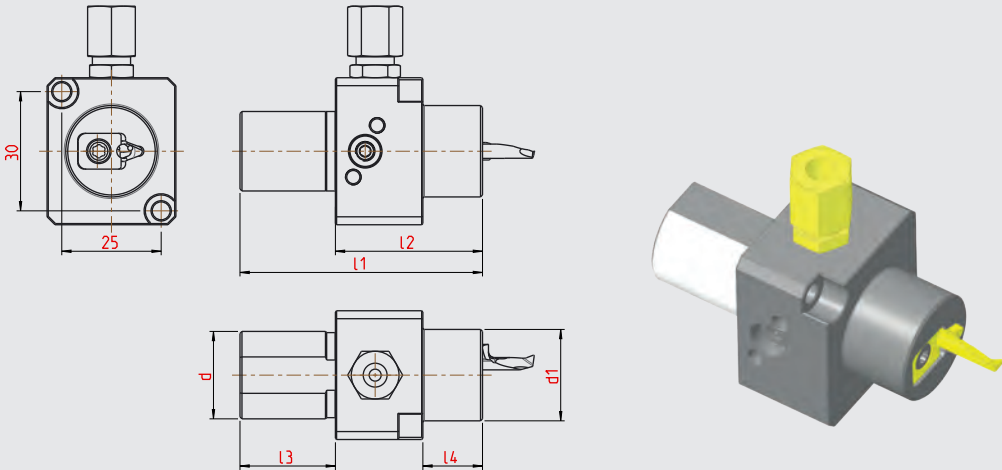





Art. Nummer Art. Number	Bezeichnung Description	d	l1	l2	l3	l4	d1	für Schneideinsatz for insert
12-1405	RHF.N.151.H105.S2.IK-03	22	61	37	24	15	23	Horn Typ 105, Größe 03
12-1406	RHF.N.151.H105.S2.IK-04	22	61	37	24	15	23	Horn Typ 105, Größe 04
12-1407	RHF.N.151.H105.S2.IK-05	22	61	37	24	15	23	Horn Typ 105, Größe 05

Abmessungen in mm
Dimensions in mm

Hinweis/Note:

Zur Bestimmung der Keilgröße, entnehmen Sie die Maße „b“ aus den HORN-Katalogen
To determine the wedge size, refer to the dimensions „b“ in the HORN catalogues

Ersatzteile / Spare parts

Art.-Nr:				
12-1405	001.01.36	004.00.19	001.00.19	4.352.03
12-1406	001.01.36	004.00.19	001.00.19	4.352.04
12-1407	001.01.36	004.00.19	001.00.19	4.352.05

Rückseitenhalter für HORN Schneideinsatz Typ 105.. Back working holder HORN insert type 105..

Lochbild S2
hole pattern S2

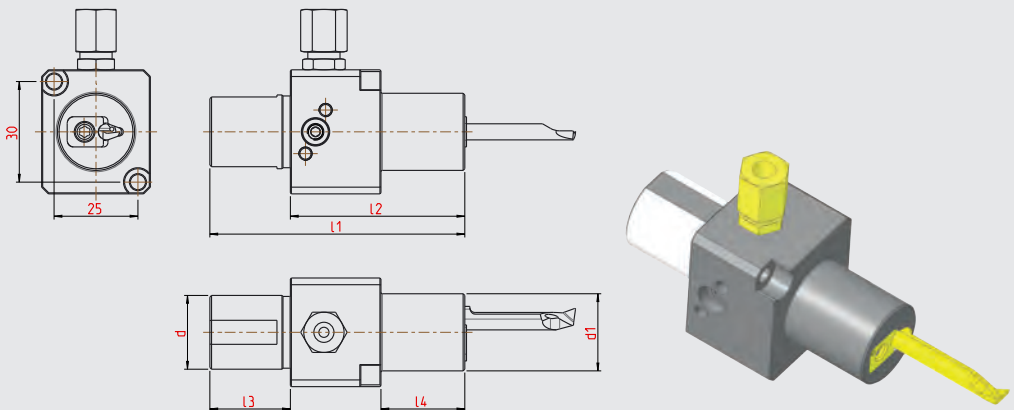





Art. Nummer Art. Number	Bezeichnung Description	d	l1	l2	l3	l4	d1	für Schneideinsatz for insert
12-1399	RHF.N.152.H105.S2.IK-03	22	76	52	24	25	23	Horn Typ 105, Größe 03
12-1400	RHF.N.152.H105.S2.IK-04	22	76	52	24	25	23	Horn Typ 105, Größe 04
12-1401	RHF.N.152.H105.S2.IK-05	22	76	52	24	25	23	Horn Typ 105, Größe 05

Abmessungen in mm
Dimensions in mm

Hinweis/Note:

Zur Bestimmung der Keilgröße, entnehmen Sie die Maße „b“ aus den HORN-Katalogen
To determine the wedge size, refer to the dimensions „b“ in the HORN catalogues

Ersatzteile / Spare parts

Art.-Nr:				
12-1399	001.01.36	004.00.19	001.00.142	4.352.03
12-1400	001.01.36	004.00.19	001.00.142	4.352.04
12-1401	001.01.36	004.00.19	001.00.142	4.352.05

Pendelhalter
Floating holder

Lochbild S2
hole pattern S2

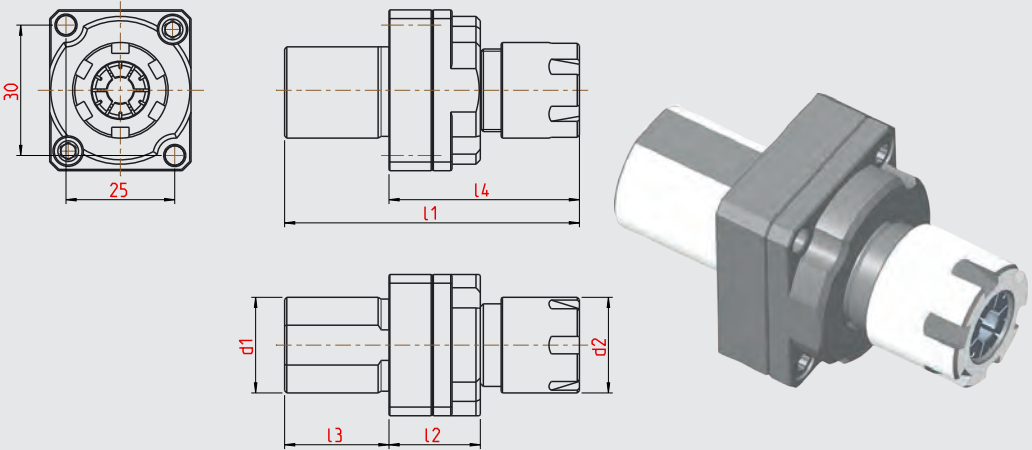

Art. Nummer Art. Number	Bezeichnung Description	d	l1	l2	l3	l4	d2	für Spannzange for collet
11-3235	GP70.2224.11.S2	22	62,5	21	24	38,5	16	ER11
11-3238	GP70.2224.16.S2	22	68	21	24	44	22	ER16

Abmessungen in mm
Dimensions in mm

Ersatzteile / Spare parts

Art.-Nr:		
11-3235	62.000.11	001.00.19
11-3238	62.000.16	001.00.19

Mehrkant-Drückgerät GDF Multi-sided equipment GDF

Lochbild S2
hole pattern S2

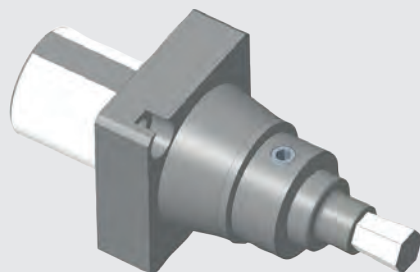
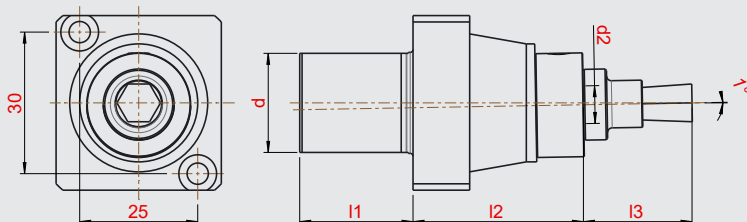

Art. Nummer Art. Number	Bezeichnung Description	d	l1	l2	l3	d2
11-1207	GDF76.2224.S2.08	22	24	36	23	8
11-1222	GDF78.2224.S2.08	22	24	49	23	8
11-1218	GDF78.2224.S2.12	22	24	49	23	12

Abmessungen in mm
Dimensions in mm

Ersatzteile / Spare parts



001.00.66

Rückseitenhalter für Schneidplatte TYP DC.. 07..
Back working holder for insert type DC.. 07..

Lochbild S2
hole pattern S2

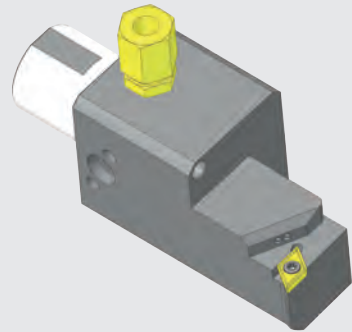
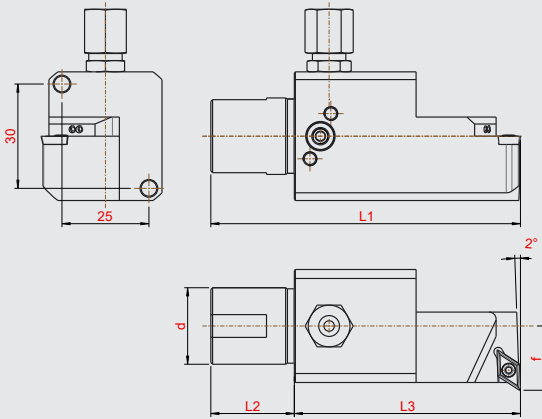

Ausführung rechtsschneidend, wie dargestellt · right cutting version as shown



Art. Nummer Art. Number	Bezeichnung Description	d	I1	I2	I3	f	für Schneidplatte for insert
12-1445	RHF.R.243.DC07.S2.IK	22	89	24	65	18	DC... 07...
12-1446	RHF.L.243.DC07.S2.IK	22	89	24	65	18	DC... 07...

Abmessungen in mm
Dimensions in mm

Hinweis/Note:

IK Anschluss oben und unten
coolant connection at the top and down

Ersatzteile / Spare parts

		
004.00.19	002.00.168	001.01.15
	002.00.170	

Rückseitenhalter für Schneidplatte TYP DC.. 07.. Back working holder for insert type DC.. 07..

Lochbild S2
hole pattern S2

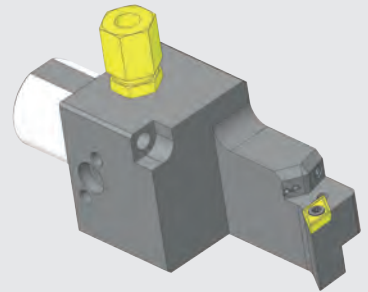
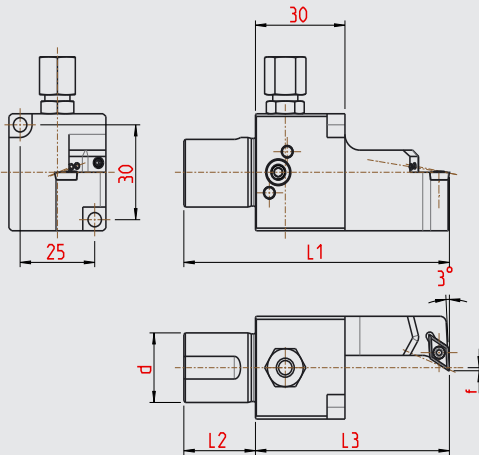

Ausführung rechtsschneidend, wie dargestellt · right cutting version as shown



Art. Nummer Art. Number	Bezeichnung Description	d	l1	l2	l3	f	für Schneidplatte for insert
12-1526	RHF.R.265.DC07.S2.IK	22	89	24	65	1	DC... 07...
12-1598	RHF.L.265.DC07.S2.IK	22	89	24	65	1	DC... 07...

Abmessungen in mm
Dimensions in mm

Hinweis/Note:

IK Anschluss oben und unten
coolant connection at the top and down

Ersatzteile / Spare parts

		
004.00.19	002.00.166	001.01.01
	002.00.168	
	002.00.170	

Rückseitenhalter für Schneidplatte Typ DC..11..
Back working holder for insert type DC..11..

Lochbild S2
hole pattern S2

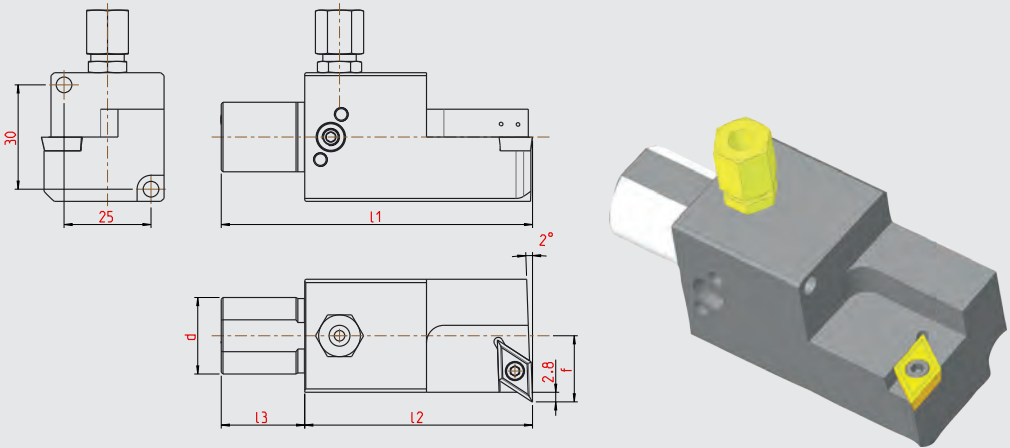

Ausführung rechtsschneidend, wie dargestellt · right cutting version as shown

Art. Nummer Art. Number	Bezeichnung Description	d	I1	I2	I3	f	für Schneidplatte for insert
12-1063	RHF.R.153.DC11.S2.IK	22	89	65	24	19	DC... 11...
12-1058	RHF.L.153.DC11.S2.IK	22	89	65	24	19	DC... 11...

Abmessungen in mm
Dimensions in mm

Hinweis/Note:

IK Anschluss oben und unten
coolant connection at the top and down

Ersatzteile / Spare parts

		
001.01.15	004.00.19	001.00.108
		001.00.145

Rückseitenhalter für Schneidplatte Typ DC..11.. Back working holder for insert type DC..11..

Lochbild S2
hole pattern S2

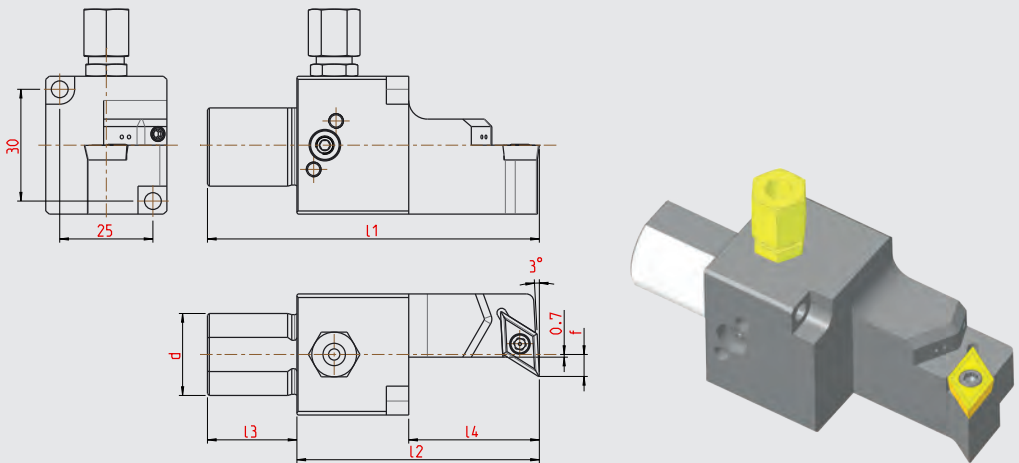

Ausführung rechtsschneidend, wie dargestellt · right cutting version as shown

Art. Nummer Art. Number	Bezeichnung Description	d	l1	l2	l3	f	l4	für Schneidplatte for insert
12-1334	RHF.R.207.DC11.S2.IK	22	89	65	24	5,9	25	DC... 11...
12-1335	RHF.L.207.DC11.S2.IK	22	89	65	24	5,9	25	DC... 11...

Abmessungen in mm
Dimensions in mm

Hinweis/Note:

IK Anschluss oben und unten
coolant connection at the top and down

Ersatzteile / Spare parts

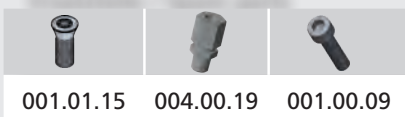

001.01.15

004.00.19

001.00.09

Rückseitenhalter für Schneidplatte Typ DC..11..
Back working holder for insert type DC..11..

Lochbild S2
hole pattern S2

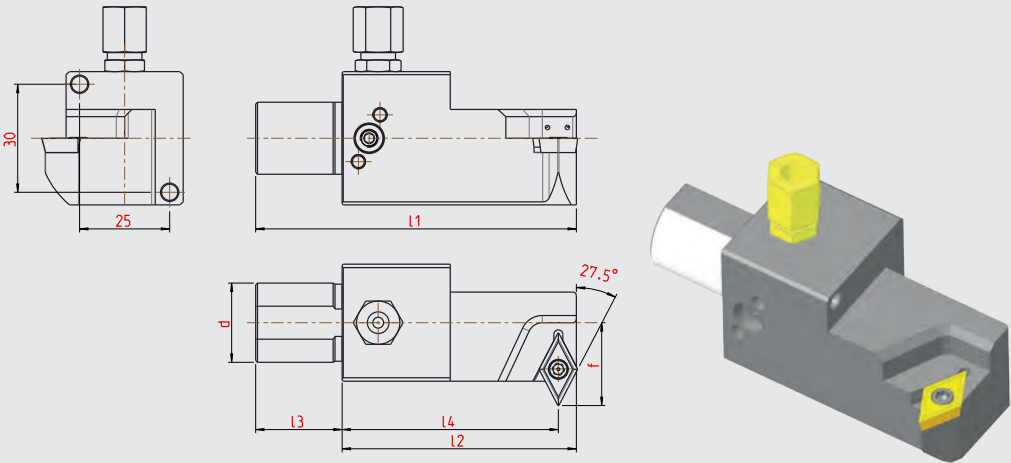

Ausführung rechtsschneidend, wie dargestellt · right cutting version as shown

Art. Nummer Art. Number	Bezeichnung Description	d	l1	l2	l3	f	l4	für Schneidplatte for insert
12-1362	RHF.R.219.DC11.S2.IK	22	89	65	24	23	60	DC... 11...
12-1363	RHF.L.219.DC11.S2.IK	22	89	65	24	23	60	DC... 11...

Abmessungen in mm
Dimensions in mm

Hinweis/Note:

IK Anschluss oben und unten
coolant connection at the top and down

Ersatzteile / Spare parts



001.01.15 004.00.19 001.00.143

Rückseitenhalter für Schneidplatte Typ DC..11..

Back working holder for insert type DC..11..

Lochbild S2
hole pattern S2

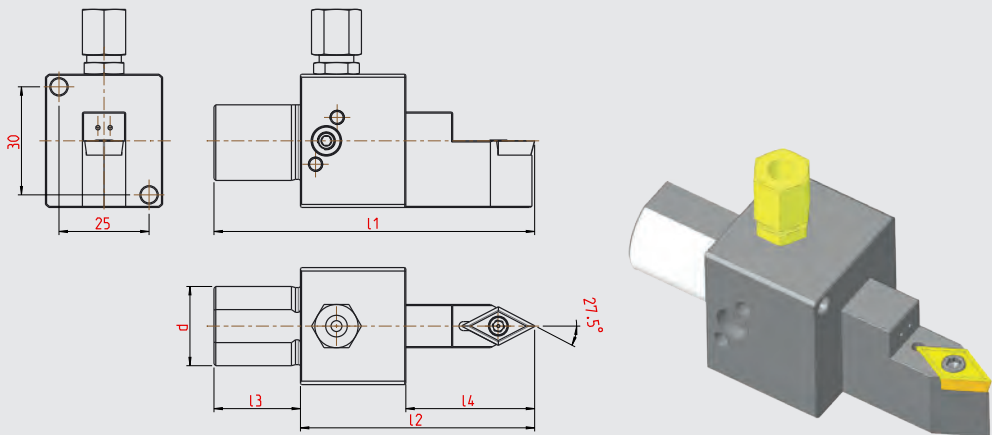

Art. Nummer Art. Number	Bezeichnung Description	d	l1	l2	l3	l4	für Schneidplatte for insert
12-1374	RHF.N.224.DC11.S2.IK	22	89	65	24	36	DC... 11...

Abmessungen in mm
Dimensions in mm

Hinweis/Note:

IK Anschluss oben und unten
coolant connection at the top and down

Ersatzteile / Spare parts

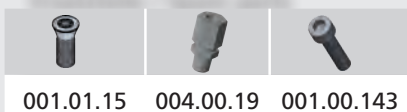

001.01.15 004.00.19 001.00.143

Rückseitenhalter für Schneidplatte Typ CC 06..
Back working holder for insert type CC 06..

Lochbild S2
hole pattern S2

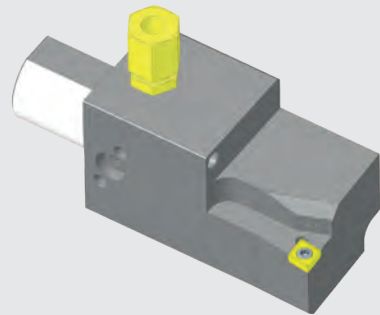
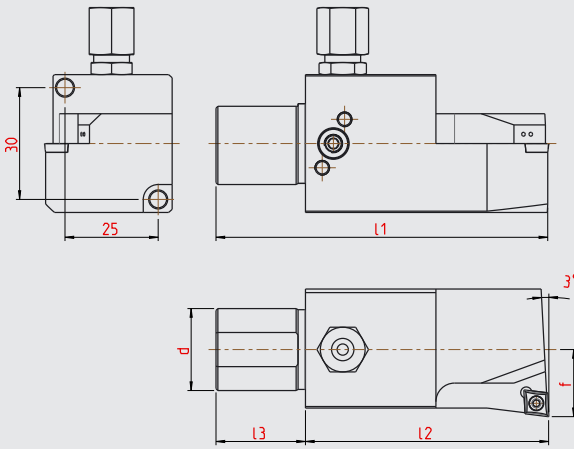

Ausführung rechtsschneidend, wie dargestellt · right cutting version as shown

Art. Nummer Art. Number	Bezeichnung Description	d	l1	l2	l3	f	für Schneidplatte for insert
12-1129	RHF.R.158.CC06.S2.IK	22	89	65	24	18	CC06...
12-1128	RHF.L.158.CC06.S2.IK	22	89	65	24	18	CC06...

Abmessungen in mm
Dimensions in mm

Hinweis/Note:

IK Anschluss oben und unten
coolant connection at the top and down

Ersatzteile / Spare parts

Art.-Nr:			
12-1129	001.01.01	004.00.19	001.00.108
12-1128	001.01.01	004.00.19	001.00.108/144

Rückseitenhalter für Schneidplatte Typ CC 09..
Back working holder for insert type CC 09..

Lochbild S2
 hole pattern S2

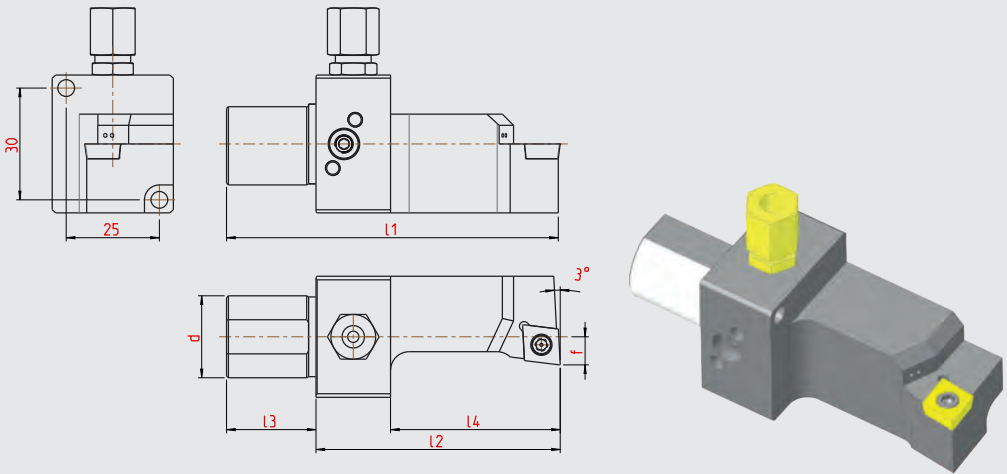

Ausführung rechtsschneidend, wie dargestellt · right cutting version as shown



Art. Nummer Art. Number	Bezeichnung Description	d	l1	l2	l3	f	l4	für Schneidplatte for insert
12-1170	RHF.R.144.CC09.S2.IK	22	89	65	24	7,5	45	CC09...
12-1195	RHF.L.144.CC09.S2.IK	22	89	65	24	7,5	45	CC09...

Abmessungen in mm
 Dimensions in mm

Hinweis/Note:

IK Anschluss oben und unten
 coolant connection at the top and down

Ersatzteile / Spare parts

Art.-Nr:			
12-1170	001.01.15	004.00.19	001.00.142/144
12-1195	001.01.15	004.00.19	001.00.144

Rückseitenhalter für Schneidplatte Typ CC 09..
Back working holder for insert type CC 09..

Lochbild S2
hole pattern S2

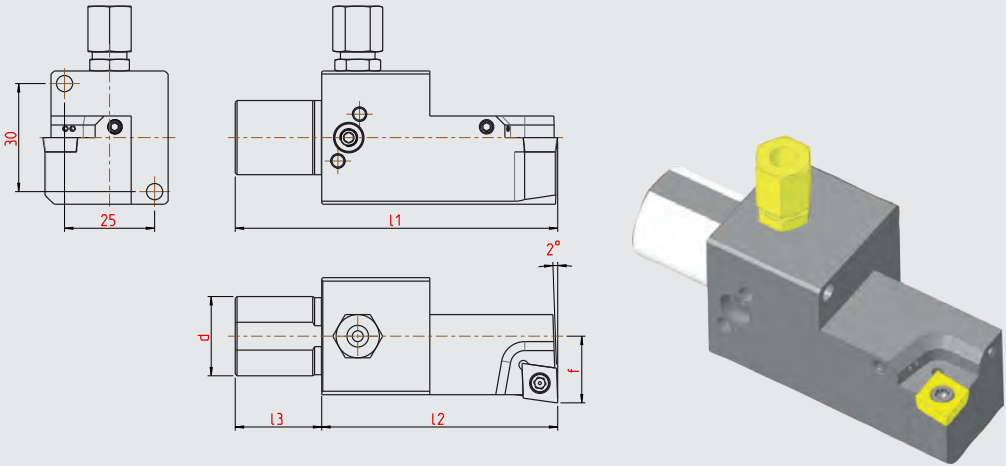

Ausführung rechtsschneidend, wie dargestellt · right cutting version as shown

Art. Nummer Art. Number	Bezeichnung Description	d	l1	l2	l3	f	für Schneidplatte for insert
12-1340	RHF.R.210.CC09.S2.IK	22	89	65	24	18,5	CC09...
12-1341	RHF.L.210.CC09.S2.IK	22	89	65	24	18,5	CC09...

Abmessungen in mm
Dimensions in mm

Hinweis/Note:

IK Anschluss oben und unten
coolant connection at the top and down

Ersatzteile / Spare parts

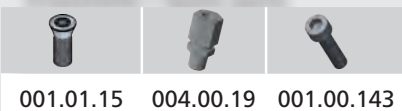

Rückseitenhalter für Schneidplatte TYP VC.. 07.. Back working holder for insert type VC.. 07..

Lochbild S2
hole pattern S2

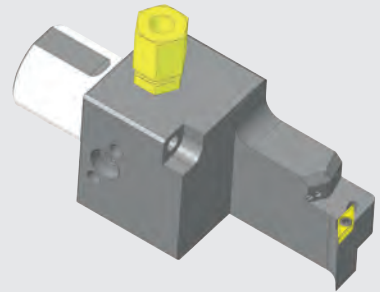
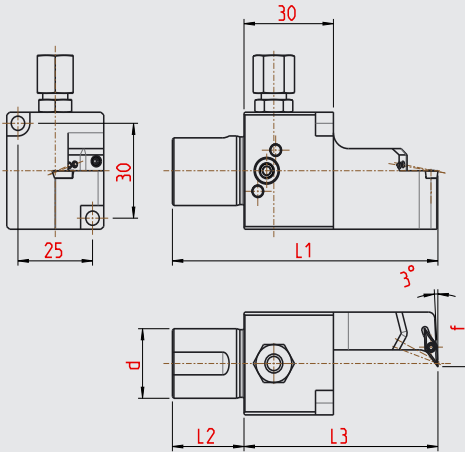

Ausführung rechtsschneidend, wie dargestellt · right cutting version as shown



Art. Nummer Art. Number	Bezeichnung Description	d	l1	l2	l3	f	für Schneidplatte for insert
12-1527	RHF.R.266.VC07.S2.IK	22	89	24	65	1	VC... 07...
12-1599	RHF.L.266.VC07.S2.IK	22	89	24	65	1	VC... 07...

Abmessungen in mm
Dimensions in mm

Hinweis/Note:

IK Anschluss oben und unten
coolant connection at the top and down

Ersatzteile / Spare parts

		
004.00.19	002.00.166	001.01.01
	002.00.168	
	002.00.170	

Rückseitenhalter für Schneidplatte Typ VC..11..
Back working holder for insert type VC..11..

Lochbild S2
hole pattern S2

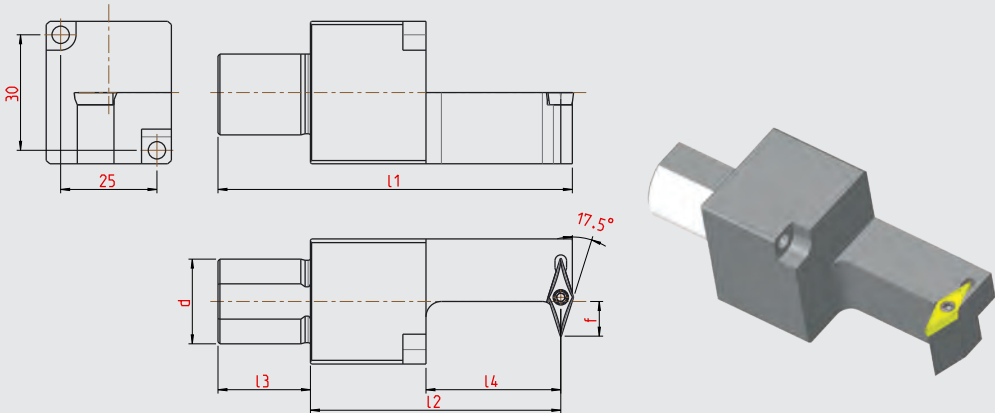

Ausführung rechtsschneidend, wie dargestellt · right cutting version as shown

Art. Nummer Art. Number	Bezeichnung Description	d	l1	l2	l3	f	l4	für Schneidplatte for insert
12-1101	RHF.R.155.VC11.S2	22	92	65	24	9	35	VC... 11...
12-1193	RHF.L.155.VC11.S2	22	92	65	24	9	35	VC... 11...

Abmessungen in mm
Dimensions in mm

Hinweis/Note:

ohne IK
no internal cooling

Ersatzteile / Spare parts



001.01.08

001.00.09

Rückseitenhalter für Schneidplatte Typ VC..11.. Back working holder for insert type VC..11..

Lochbild S2
hole pattern S2

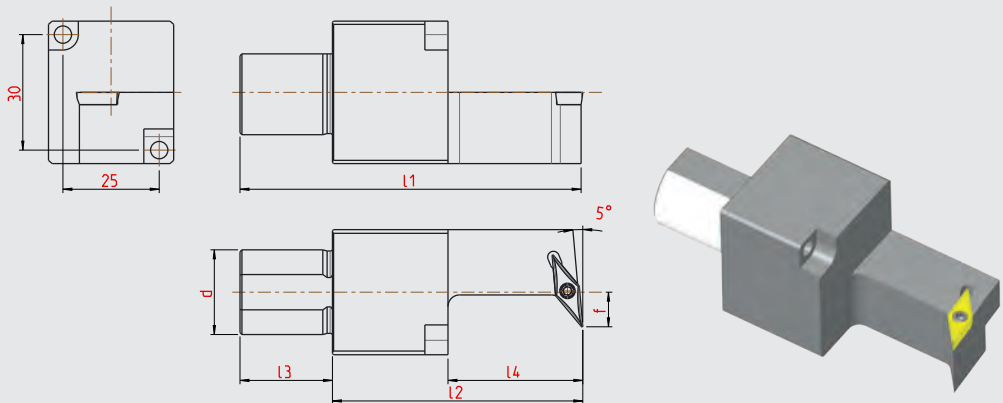

Ausführung rechtsschneidend, wie dargestellt · right cutting version as shown

Art. Nummer Art. Number	Bezeichnung Description	d	l1	l2	l3	f	l4	für Schneidplatte for insert
12-1100	RHF.R.156.VC11.S2	22	89	65	24	9	35	VC... 11...
12-1194	RHF.L.156.VC11.S2	22	89	65	24	9	35	VC... 11...

Abmessungen in mm
Dimensions in mm

Hinweis/Note:

ohne IK
no internal cooling

Ersatzteile / Spare parts



001.01.08

001.00.09

Rückseitenhalter für Schneidplatte Typ VC..11..
Back working holder for insert type VC..11..

Lochbild S2
hole pattern S2

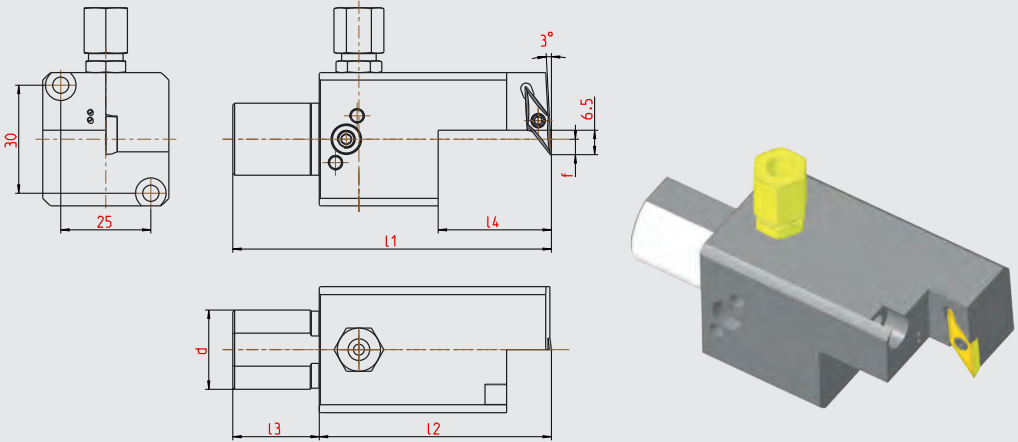

Ausführung rechtsschneidend, wie dargestellt/Überkopf · right cutting version as shown/facing upside

Art. Nummer Art. Number	Bezeichnung Description	d	l1	l2	l3	f	l4	für Schneidplatte for insert
12-1093	RHF.R.154.VC11.S2.IK	22	89	65	24	4,5	32	VC... 11...

Abmessungen in mm
Dimensions in mm

Hinweis/Note:

IK Anschluss oben und unten
coolant connection at the top and down

Ersatzteile / Spare parts

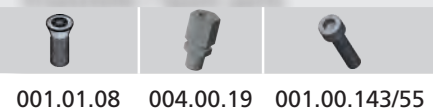

Rückseitenhalter für Schneidplatte Typ VC..11.. Back working holder for insert type VC..11..

Lochbild S2
hole pattern S2

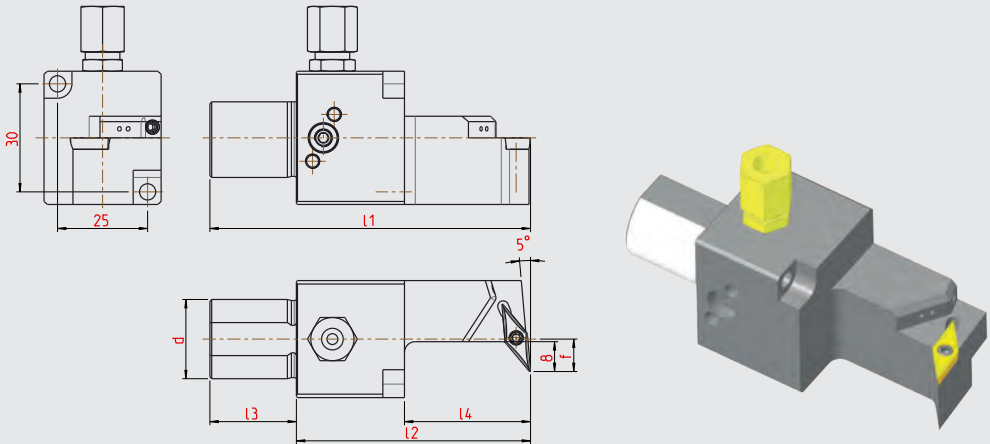

Ausführung rechtsschneidend, wie dargestellt · right cutting version as shown

Art. Nummer Art. Number	Bezeichnung Description	d	l1	l2	l3	f	l4	für Schneidplatte for insert
12-1220	RHF.R.156.VC11.S2.IK	22	89	65	24	9	35	VC... 11...
12-1221	RHF.L.156.VC11.S2.IK	22	89	65	24	9	35	VC... 11...

Abmessungen in mm
Dimensions in mm

Hinweis/Note:

IK Anschluss oben und unten
coolant connection at the top and down

Ersatzteile / Spare parts

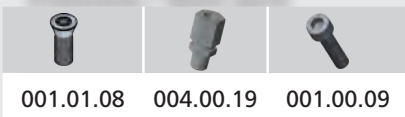

001.01.08

004.00.19

001.00.09

Rückseitenhalter für Schneidplatte TYP VC.. 11..
Back working holder for insert type VC.. 11..

Lochbild S2
hole pattern S2

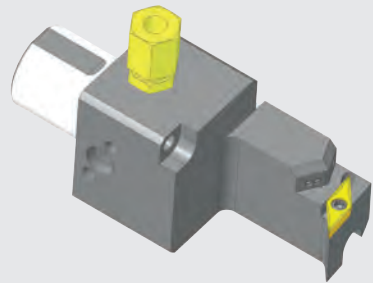
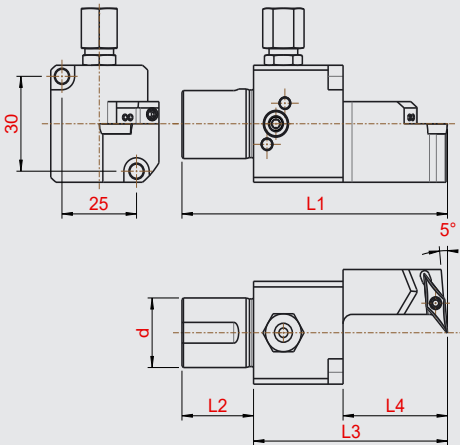

Ausführung rechtsschneidend, wie dargestellt · right cutting version as shown



Art. Nummer Art. Number	Bezeichnung Description	d	l1	l2	l3	l4	für Schneidplatte for insert
12-1473	RHF.R.249.VC11.S2.IK	22	89	24	65	35	VC... 11...
12-1474	RHF.L.249.VC11.S2.IK	22	89	24	65	35	VC... 11...

Abmessungen in mm
Dimensions in mm

Hinweis/Note:

IK Anschluss oben und unten
coolant connection at the top and down

Ersatzteile / Spare parts

		
004.00.19	002.00.166	001.01.01
	002.00.168	
	002.00.170	

Rückseitenhalter für Schneidplatte Typ VC..13..

Back working holder for insert type VC..13..

Lochbild S2
hole pattern S2

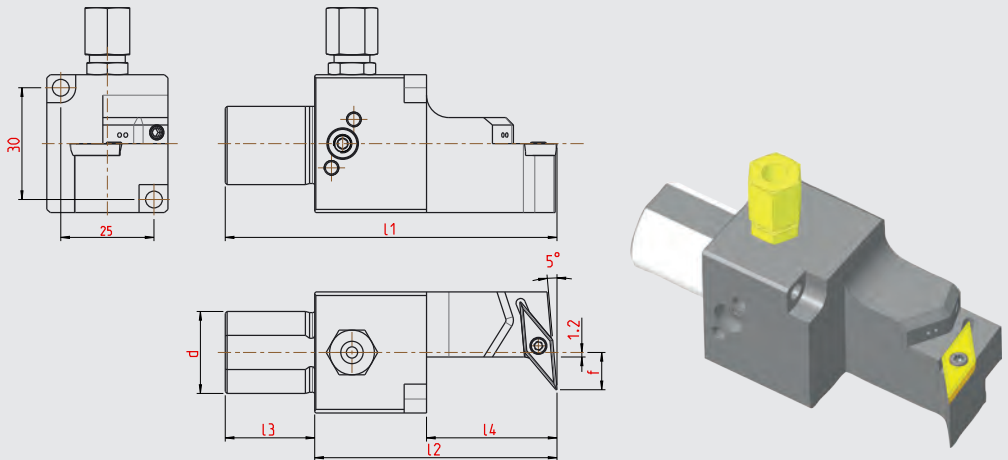

Ausführung rechtsschneidend, wie dargestellt · right cutting version as shown

Art. Nummer Art. Number	Bezeichnung Description	d	l1	l2	l3	f	l4	für Schneidplatte for insert
12-1336	RHF.R.208.VC13.S2.IK	22	89	65	24	10	35	VC... 13...
12-1337	RHF.L.208.VC13.S2.IK	22	89	65	24	10	35	VC... 13...

Abmessungen in mm
Dimensions in mm

Hinweis/Note:

IK Anschluss oben und unten
coolant connection at the top and down

Ersatzteile / Spare parts

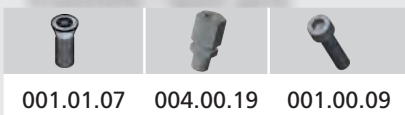

Rückseitenhalter für Schneidplatte TYP VC.. 13..
Back working holder for insert type VC.. 13..

Lochbild S2
hole pattern S2

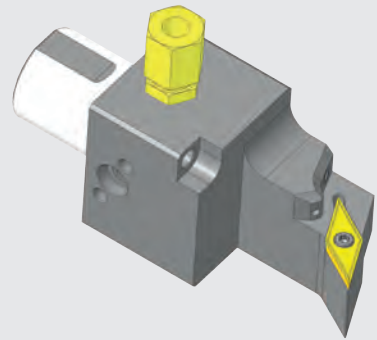
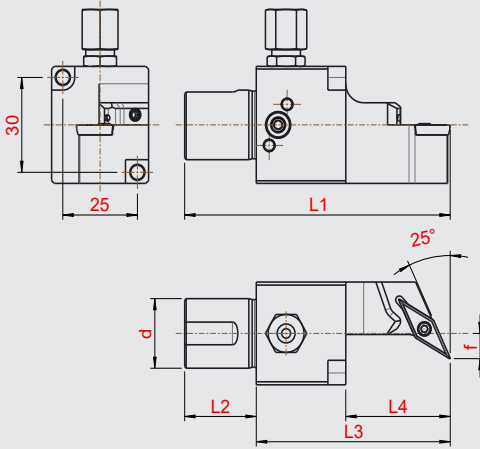

Ausführung rechtsschneidend, wie dargestellt · right cutting version as shown



Art. Nummer Art. Number	Bezeichnung Description	d	l1	l2	l3	l4	f	für Schneidplatte for insert
12-1493	RHF.R.255.VC13.S2.IK	22	89	24	65	35	8	VC... 13...
12-1494	RHF.L.255.VC13.S2.IK	22	89	24	65	35	8	VC... 13...

Abmessungen in mm
Dimensions in mm

Hinweis/Note:

IK Anschluss oben und unten
coolant connection at the top and down

Ersatzteile / Spare parts

		
004.00.19	002.00.166	001.01.07
	002.00.168	
	002.00.170	

Rückseitenhalter für Schneidplatte Typ VC..16.. Back working holder for insert type VC..16..

Lochbild S2
hole pattern S2

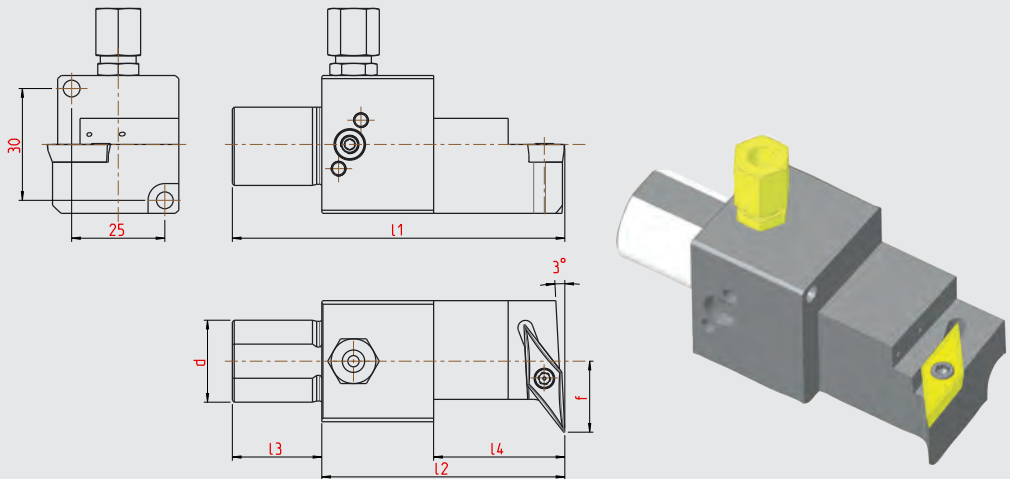

Ausführung rechtsschneidend, wie dargestellt · right cutting version as shown

Art. Nummer Art. Number	Bezeichnung Description	d	l1	l2	l3	f	l4	für Schneidplatte for insert
12-1216	RHF.R.163.VC16.S2.IK	22	89	65	24	19	35	VC... 16...
12-1217	RHF.L.163.VC16.S2.IK	22	89	65	24	19	35	VC... 16...

Abmessungen in mm
Dimensions in mm

Hinweis/Note:

IK Anschluss oben und unten
coolant connection at the top and down

Ersatzteile / Spare parts

Art.-Nr:			
12-1216	001.01.08	004.00.19	001.00.146/108
12-1217	001.01.08	004.00.19	001.00.143

Rückseitenhalter für Schneidplatte TYP VP. 10..
Back working holder for insert type VP. 10..

Lochbild S2
hole pattern S2

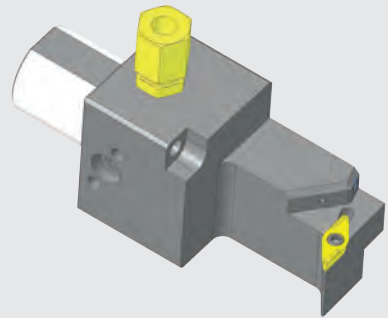
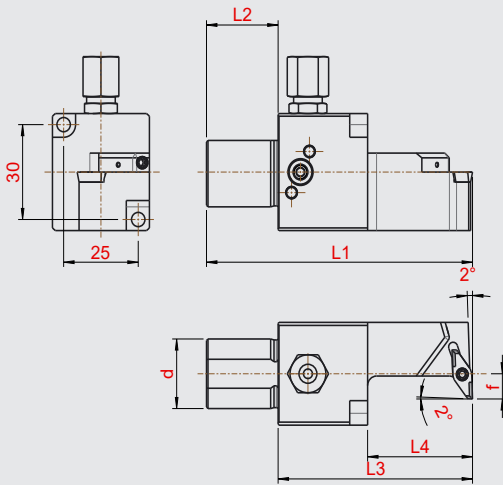

Ausführung rechtsschneidend, wie dargestellt · right cutting version as shown

Art. Nummer Art. Number	Bezeichnung Description	d	I1	I2	I3	I4	f	für Schneidplatte for insert
12-1412	RHF.R.234.VP10.S2.IK	22	89	24	65	35	8	VP.. 10...
12-1413	RHF.L.234.VP10.S2.IK	22	89	24	65	35	8	VP.. 10...

Abmessungen in mm
Dimensions in mm

Hinweis/Note:

IK Anschluss oben und unten
coolant connection at the top and down

Ersatzteile / Spare parts

004.00.19	002.00.166	001.01.08
	002.00.168	
	002.00.170	

Rückseitenhalter für Schneidplatte TYP VP. 11.. Back working holder for insert type VP. 11..

Lochbild S2
hole pattern S2

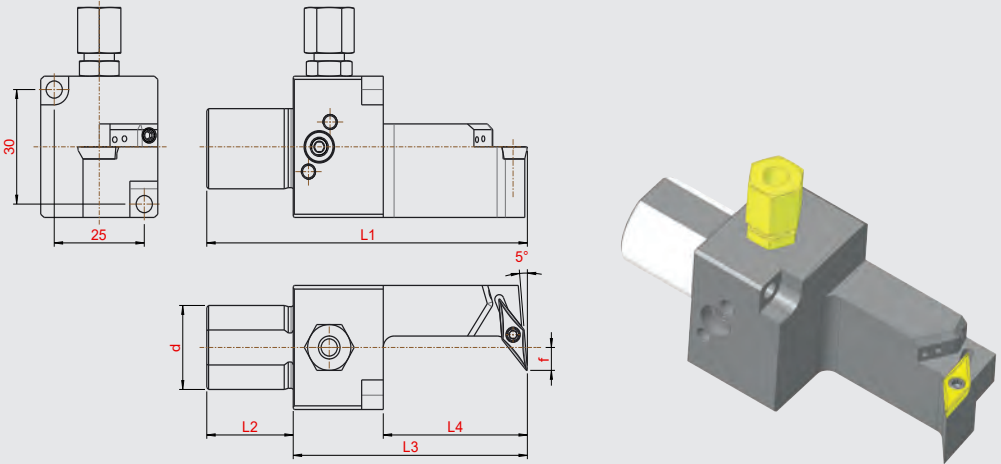

Ausführung rechtsschneidend, wie dargestellt · right cutting version as shown



Art. Nummer Art. Number	Bezeichnung Description	d	I1	I2	I3	I4	f	für Schneidplatte for insert
12-1525	RHF.R.264.VP11.S2.IK	22	89	24	65	40	8	VP.. 11...
12-1597	RHF.L.264.VP11.S2.IK	22	89	24	65	40	8	VP.. 11...

Abmessungen in mm
Dimensions in mm

Hinweis/Note:

IK Anschluss oben und unten
coolant connection at the top and down

Ersatzteile / Spare parts

		
004.00.19	002.00.166	001.01.08
	002.00.168	
	002.00.170	

Rückseitenhalter für Schneidplatte TYP TC.. 11..
Back working holder for insert type TC. 11..

Lochbild S2
hole pattern S2

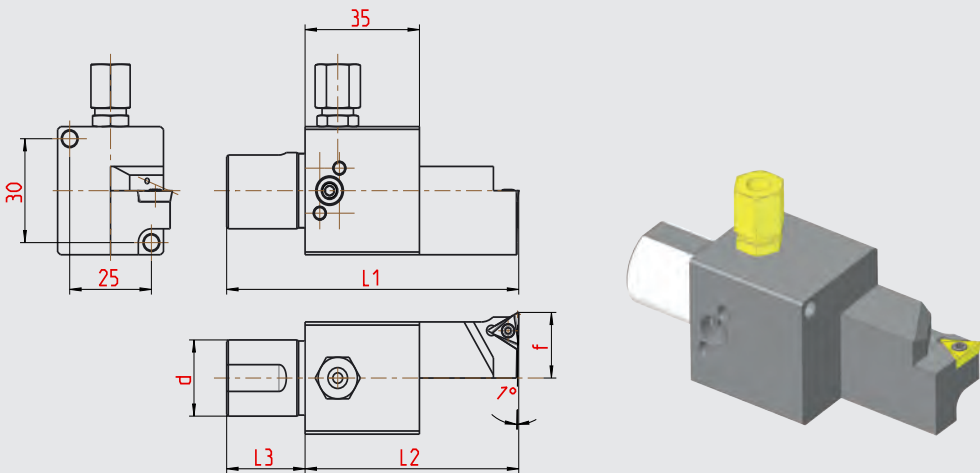

Ausführung links, wie dargestellt · left cutting version as shown



Art. Nummer Art. Number	Bezeichnung Description	d	l1	l2	l3	f	für Schneidplatte for insert
12-1483	RHF.R.252.TC11.S2.IK	22	89	65	65	19	TC... 11...
12-1484	RHF.L.252.TC11.S2.IK	22	89	65	65	19	TC... 11...

Abmessungen in mm
Dimensions in mm

Hinweis/Note:

IK Anschluss oben und unten
coolant connection at the top and down

Ersatzteile / Spare parts

		
004.00.19	002.00.168	001.01.01
	002.00.170	

Rückseitenhalter für Schneidplatte TYP YW.. 11.. Back working holder for insert type YW.. 11..

Lochbild S2
hole pattern S2

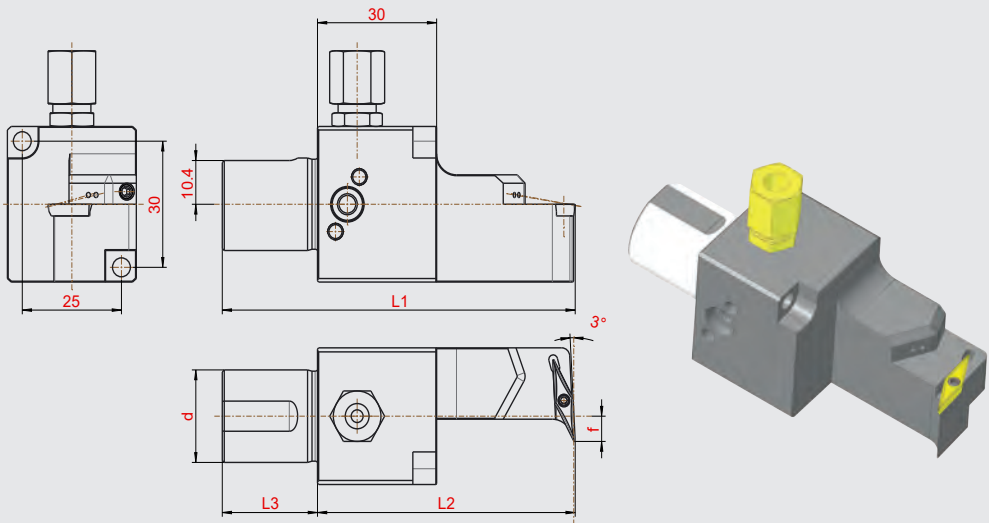

Ausführung rechtsschneidend, wie dargestellt · right cutting version as shown

Art. Nummer Art. Number	Bezeichnung Description	d	I1	I2	I3	f	für Schneidplatte for insert
12-1607	RHF.R.290.YW11.S2.IK	22	89	65	24	6	YW... 11...
12-1608	RHF.L.290.YW11.S2.IK	22	89	65	24	6	YW... 11...

Abmessungen in mm
Dimensions in mm

Hinweis/Note:

IK Anschluss oben und unten
coolant connection at the top and down

Ersatzteile / Spare parts

			
004.00.19	002.00.167	001.01.25	001.00.09
	002.00.170		

Rückseitenhalter für Schneidplatte Typ 16 ER/EL..
Back working holder for insert type 16 ER/EL..

Lochbild S2
hole pattern S2

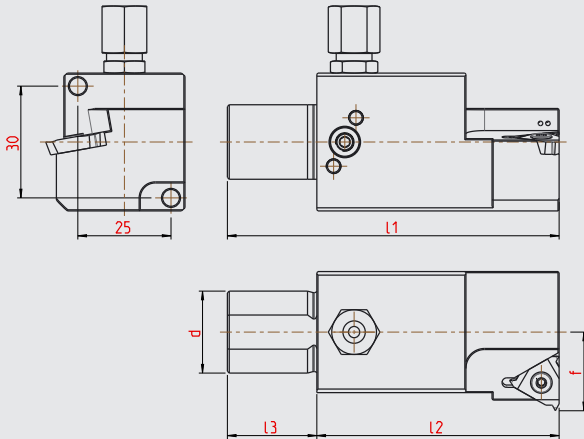

Ausführung rechtsschneidend, wie dargestellt · right cutting version as shown

Art. Nummer Art. Number	Bezeichnung Description	d	l1	l2	l3	f	für Schneidplatte for insert
12-1064	RHF.R.157.16ER.S2.IK	22	89	65	24	21	16ER
12-1060	RHF.L.157.16EL.S2.IK	22	89	65	24	21	16EL

Abmessungen in mm
Dimensions in mm

Hinweis/Note:

IK Anschluss oben und unten
coolant connection at the top and down

Ersatzteile / Spare parts

Art.-Nr:			
12-1064	001.01.65	004.00.19	001.00.109/146
12-1060	001.01.65	004.00.19	001.00.109/146

Berechnung Steigungswinkel
auf Seite 125-126.
Calculation helix angles
on page 125-126.

Rückseitenhalter für Schneidplatte TYP G.. 0004..

Back working holder for insert type G.. 0004..

Lochbild S2
hole pattern S2

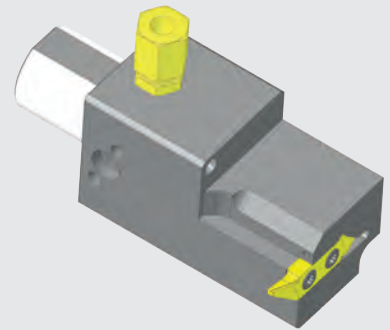
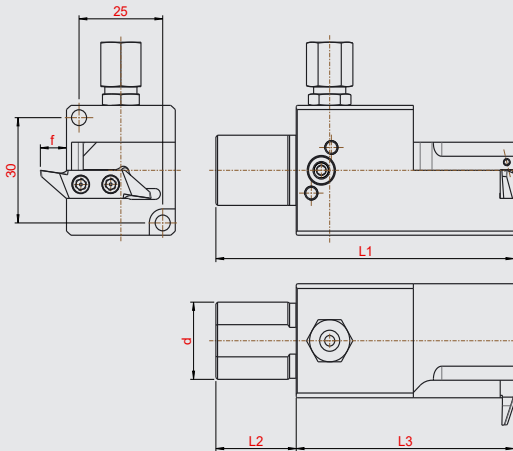

Ausführung rechtsschneidend, wie dargestellt · right cutting version as shown



Art. Nummer Art. Number	Bezeichnung Description	d	l1	l2	l3	f	für Schneidplatte for insert
12-1414	RHF.R.235.G0004.S2.IK	22	89	24	65	8	G.. 0004..
12-1415	RHF.L.235.G0004.S2.IK	22	89	24	65	8	G.. 0004..

Abmessungen in mm
Dimensions in mm

Hinweis/Note:

IK Anschluss oben und unten
coolant connection at the top and down

Ersatzteile / Spare parts

		
004.00.19	002.00.167	001.01.25
	002.00.170	

Rückseitenhalter für Schneidplatte Typ HORN S274
Back working holder for insert type HORN S274

Lochbild S2
hole pattern S2

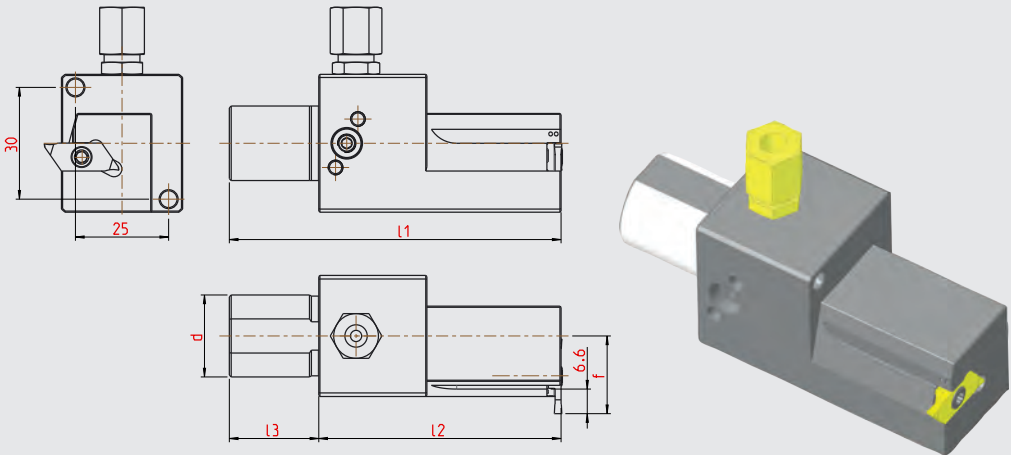

Ausführung rechtsschneidend, wie dargestellt · right cutting version as shown

Art. Nummer Art. Number	Bezeichnung Description	d	l1	l2	l3	f	für Schneidplatte for insert
12-1276	RHF.R.189.S274.S2.IK	22	89	65	24	21	HORN S274
12-1277	RHF.L.189.S274.S2.IK	22	89	65	24	21	HORN S274

Abmessungen in mm
Dimensions in mm

Hinweis/Note:

IK Anschluss oben und unten
coolant connection at the top and down

Ersatzteile / Spare parts

Art.-Nr:			
12-1276	001.01.15	004.00.19	001.00.143
12-1277	001.01.15	004.00.19	001.00.143/146

Rückseitenhalter für Schneidplatte Typ HORN 312 Back working holder for insert type HORN 312

Lochbild S2
hole pattern S2

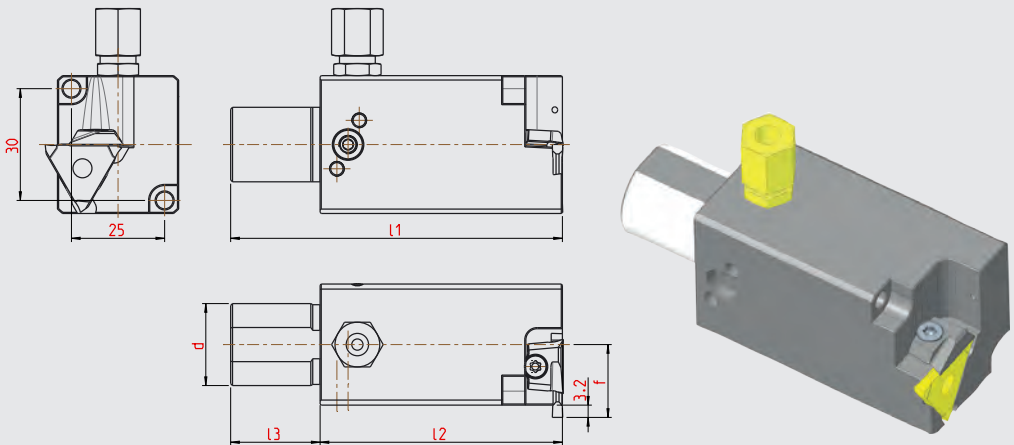

Ausführung rechtsschneidend, wie dargestellt · right cutting version as shown

Art. Nummer Art. Number	Bezeichnung Description	d	l1	l2	l3	f	für Schneidplatte for insert
12-1364	RHF.R.220.H312.01.S2.IK	22	89	65	24	19,5	HORN Typ 312 0,5-1,9
12-1365	RHF.L.220.H312.01.S2.IK	22	89	65	24	19,5	HORN Typ 312 0,5-1,9

Abmessungen in mm
Dimensions in mm

Hinweis/Note:

IK Anschluss oben und unten
coolant connection at the top and down

Ersatzteile / Spare parts

Art.-Nr:			
12-1364	4117R	004.00.19	001.00.144/146
12-1365	4156L	004.00.19	001.00.144/146

Rückseitenhalter für Schneidplatte Typ HORN 312
Back working holder for insert type HORN 312

Lochbild S2
hole pattern S2

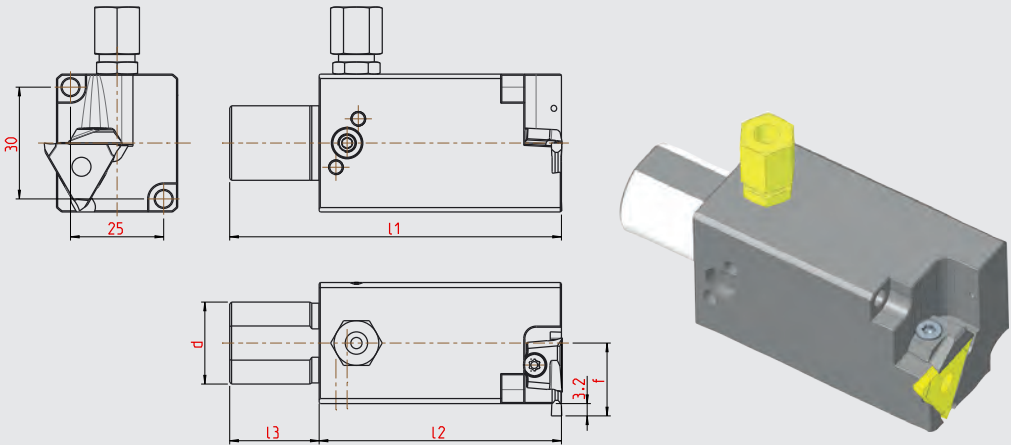

Ausführung rechtsschneidend, wie dargestellt · right cutting version as shown

Art. Nummer Art. Number	Bezeichnung Description	d	l1	l2	l3	f	für Schneidplatte for insert
12-1366	RHF.R.221.H312.02.S2.IK	22	89	65	24	19,5	HORN Typ 312 1,9-2,9
12-1367	RHF.L.221.H312.02.S2.IK	22	89	65	24	19,5	HORN Typ 312 1,9-2,9

Abmessungen in mm
Dimensions in mm

Hinweis/Note:

IK Anschluss oben und unten
coolant connection at the top and down

Ersatzteile / Spare parts

Art.-Nr:			
12-1366	4117R	004.00.19	001.00.144/146
12-1367	4156L	004.00.19	001.00.144/146

Rückseitenhalter für Schneidplatte TYP HORN 315 Back working holder for insert type HORN 315

Lochbild S2
hole pattern S2

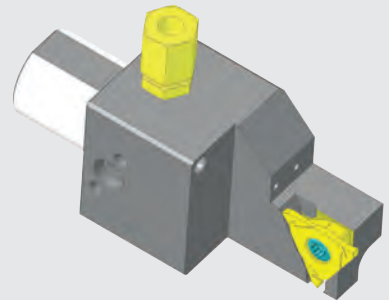
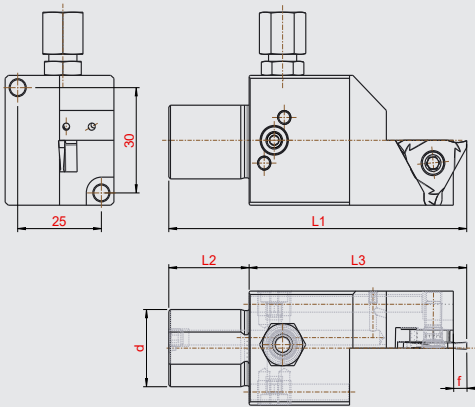



Art. Nummer Art. Number	Bezeichnung Description	l1	l2	l3	d	f	für Schneidplatte for insert
12-1542	RHF.N.271.H315.05.S2.IK	89	24	65	22	4	HORN Typ 315

Abmessungen in mm
Dimensions in mm

Hinweis/Note:

IK Anschluss oben und unten
coolant connection at the top and down

Ersatzteile / Spare parts

		
004.00.19	002.00.16	001.01.70
004.00.19	002.00.168	
002.00.170		

Rückseitenhalter für Schneidplatte Typ CS/SCD/TPCS/UPCS
Back working holder for insert type CS/SCD/TPCS/UPCS

Lochbild S2
hole pattern S2

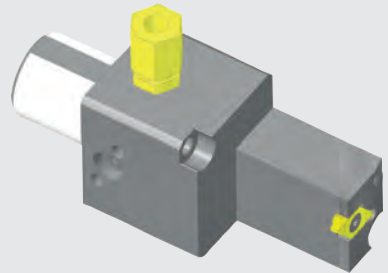
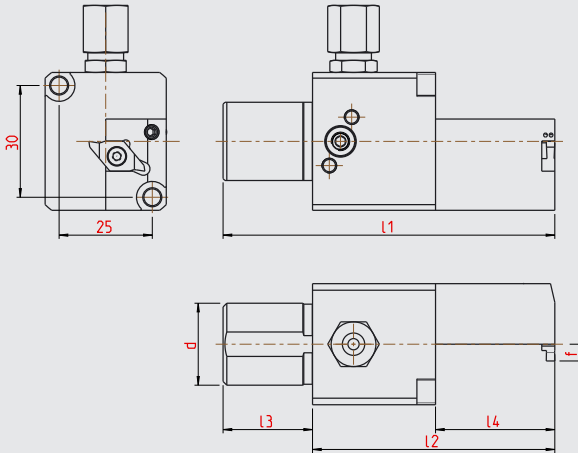

Ausführung rechtsschneidend, wie dargestellt · right cutting version as shown

Art. Nummer Art. Number	Bezeichnung Description	d	l1	l2	l3	f	l4	für Schneidplatte for insert
12-1323	RHF.R.203.CS08.S2.IK	22	89	65	24	4,5	32	CS08, SCD08
12-1324	RHF.L.203.CS08.S2.IK	22	89	65	24	4,5	32	TPCS08, UPCS08

Abmessungen in mm
Dimensions in mm

Hinweis/Note:

IK Anschluss oben und unten
coolant connection at the top and down

Ersatzteile / Spare parts



001.01.04 004.00.19 001.00.143/146

Rückseitenhalter für Schneidplatte Typ PRECI 615 Back working holder for insert type PRECI 615

Lochbild S2
hole pattern S2

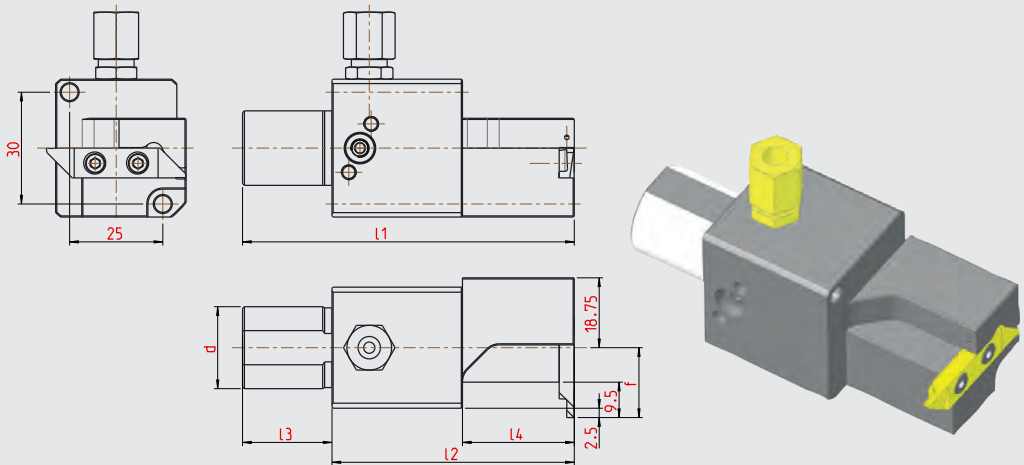

Ausführung rechtsschneidend, wie dargestellt · right cutting version as shown

Art. Nummer Art. Number	Bezeichnung Description	d	l1	l2	l3	l4	f	für Schneidplatte for insert
12-1062	RHF.R.159.P615.S2.IK	22	89	65	24	30	19	PRECI 615
12-1190	RHF.L.159.P615.S2.IK	22	89	65	24	30	19	PRECI 615

Abmessungen in mm
Dimensions in mm

Hinweis/Note:

IK Anschluss oben und unten
coolant connection at the top and down

Ersatzteile / Spare parts

Art.-Nr:			
12-1062	001.01.15	004.00.19	001.00.108/146
12-1190	001.01.15	004.00.19	001.00.108

Rückseitenhalter für Schneidplatte Typ QER 12
Back working holder for insert type QER 12

Lochbild S2
hole pattern S2

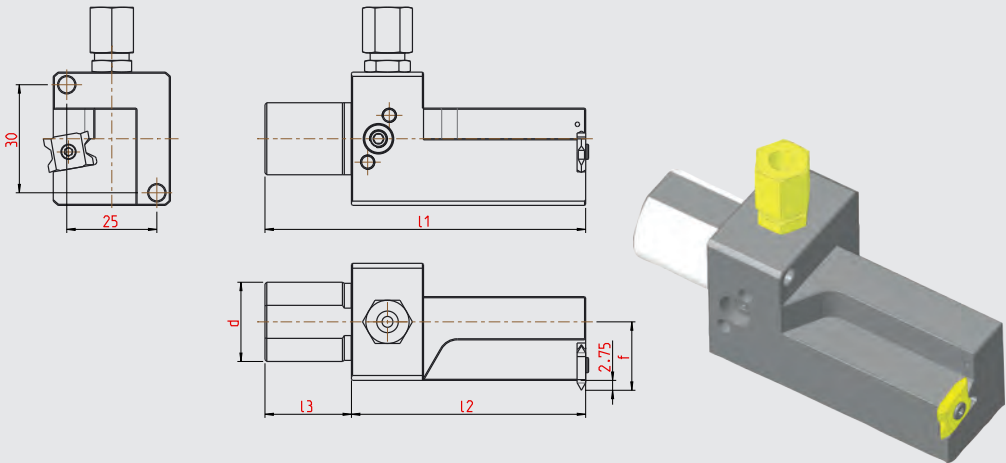

Ausführung rechtsschneidend, wie dargestellt · right cutting version as shown

Art. Nummer Art. Number	Bezeichnung Description	d	l1	l2	l3	f	für Schneidplatte for insert
12-1368	RHF.R.222.QER12.S2.IK	22	89	65	24	19	QER-12
12-1369	RHF.L.222.QER12.S2.IK	22	89	65	24	19	QER-12

Abmessungen in mm
Dimensions in mm

Hinweis/Note:

IK Anschluss oben und unten
coolant connection at the top and down

Ersatzteile / Spare parts

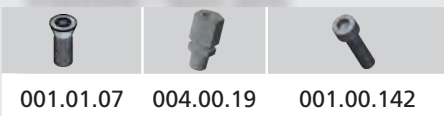

Rückseitenhalter für Vierkantschaft Back working holder for square shank

Lochbild S2
hole pattern S2

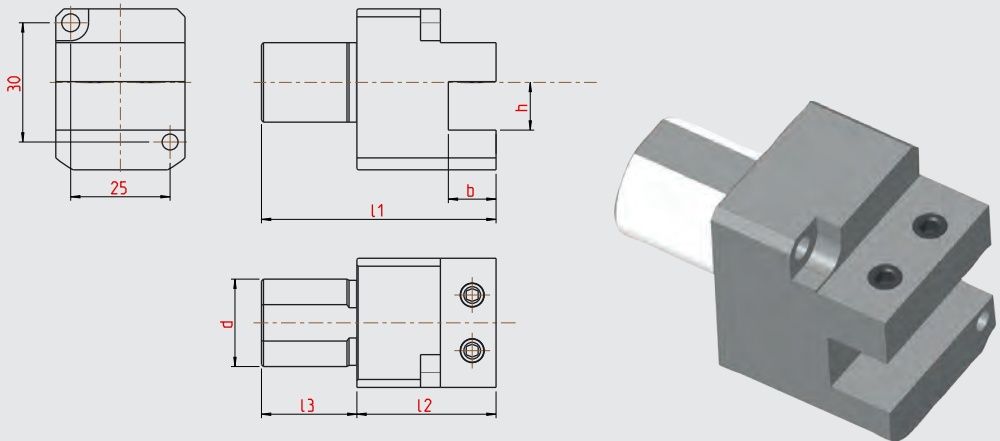

Art. Nummer Art. Number	Bezeichnung Description	d	l1	l2	l3	b	h
12-1252	RHF.N.184.1212.S2	22	59	35	24	12	12
12-1492	RHF.N.254.1616.S2	22	59	35	24	16	16
12-1502	RHF.N.258.1616.S2	22	89	65	24	16	16

Abmessungen in mm
Dimensions in mm

Ersatzteile / Spare parts

	
002.00.27	001.00.19/66
	001.00.15/42
	001.00.55/115

Gewindeschneideisenhalter Typ GS 69..
Screw threading holder type GS 69..

Lochbild S2
hole pattern S2

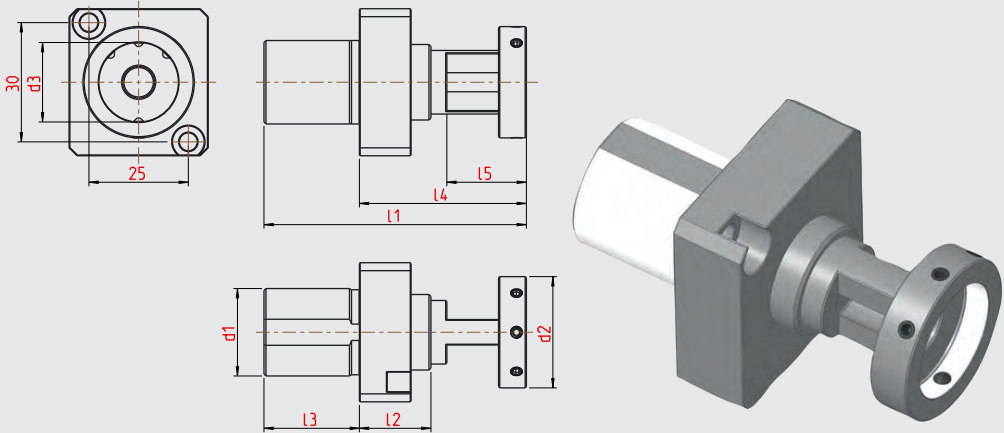

Art. Nummer Art. Number	Bezeichnung Description	d	l1	l2	l3	l4	l5	d2	d3	b
11-0403	GS69.2224.S2.1620	22	67	18	24	43	20	24	16	5
11-0398	GS69.2224.S2.2020	22	66	18	24	42	20	28	20	5
11-0405	GS69.2224.S2.2030	22	77	18	24	53	31	28	20	6

Abmessungen in mm
Dimensions in mm

Hinweis/Note:

max. Auszug 7mm
max. excerpt is 7mm

Ersatzteile / Spare parts



002.00.48 001.00.66

Zwischenstück Plate between

Lochbild S2
hole pattern S2

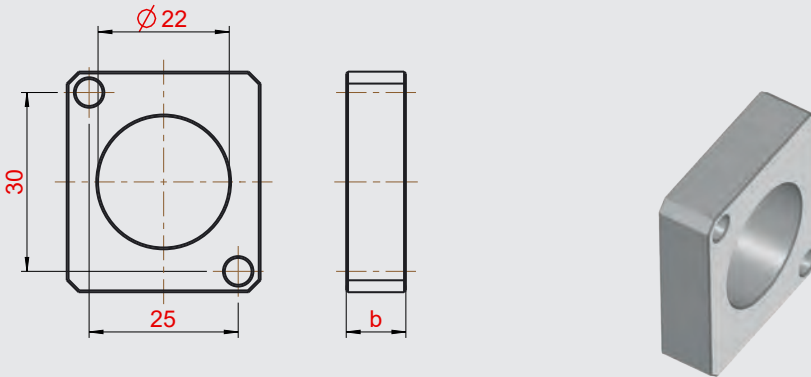

Art. Nummer Art. Number	Bezeichnung Description	b
12-1241	Z 2,5 S2	2,5
12-1240	Z 5 S2	5
12-1239	Z 10 S2	10
12-1376	Z 15 S2	15

Abmessungen in mm
Dimensions in mm

Zwischenstück
Plate between

Lochbild S2
hole pattern S2

Technischer Hinweis/Note:

Anwendung von Zwischenstücken
Application of spacers

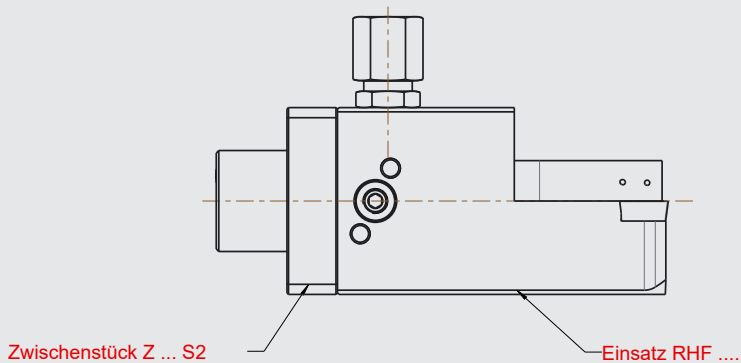
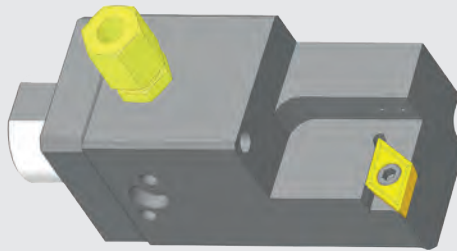

Kühlmittelbrücke für STAR S2 Halter Coolant bridge for STAR S2 holder

Art.Nr.: 004.00.76

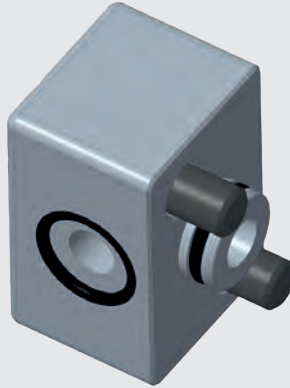

Anwendungsbeispiele für Star SR 38
Application examples for Star SR38

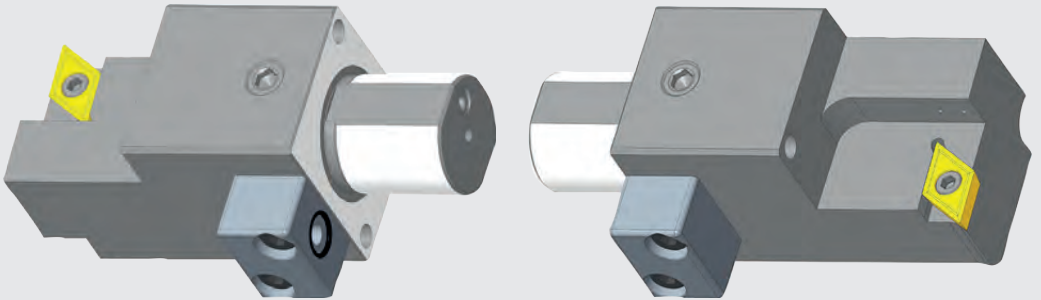

Vorteil : Direkte Kühlmittelübergabe
Advantages: direct coolant transfer

Ersatzteile / Spare parts

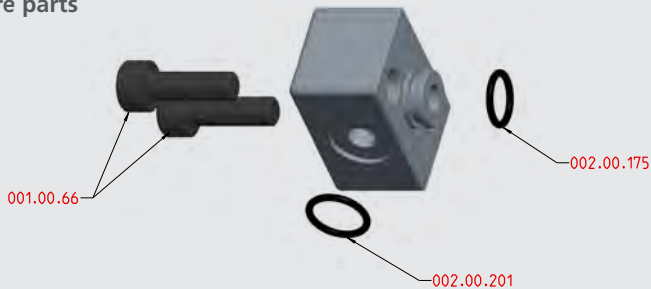

Spannzangenhalter Typ GZ 65..
Holder type GZ 65..

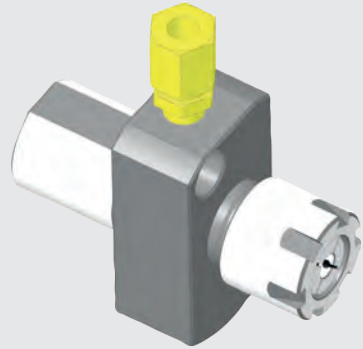
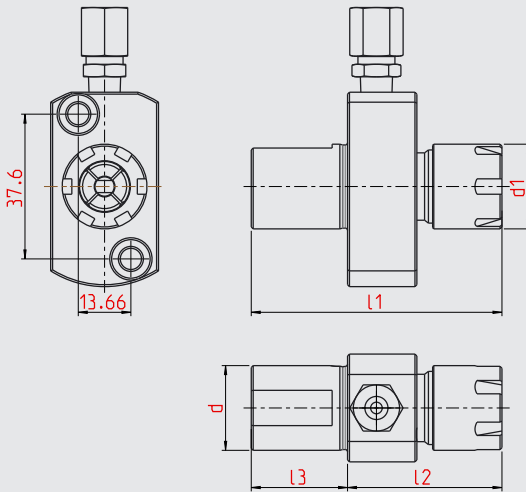

Lochbild S3
hole pattern S3



Art. Nummer Art. Number	Bezeichnung Description	d	l1	l2	l3	d1	für Spannzange for collet
11-0381	GZ65.2225.16.S3	22	66	41	25	22	ER16
11-0412	GZ65.2225.20.S3	22	71	46	25	28	ER20
11-0619	GZ65.2225.25.S3	22	74	49	25	35	ER25

Abmessungen in mm
Dimensions in mm

Ersatzteile / Spare parts

Art.-Nr:			
12-0381	004.00.19	001.00.07	62.00.16
12-0412	004.00.19	001.00.14	62.00.20
12-0619	004.00.19	001.00.07	62.00.25

Hinweis/Note:

IK Anschluss oben und unten
coolant connection at the top and down

Abdichtbare Spannmutter
muß separat bestellt werden
Sealed chucking nut
must be ordered separately

Spannzangenhalter Typ GZ 65.. Holder type GZ 65..

Lochbild S3
hole pattern S3

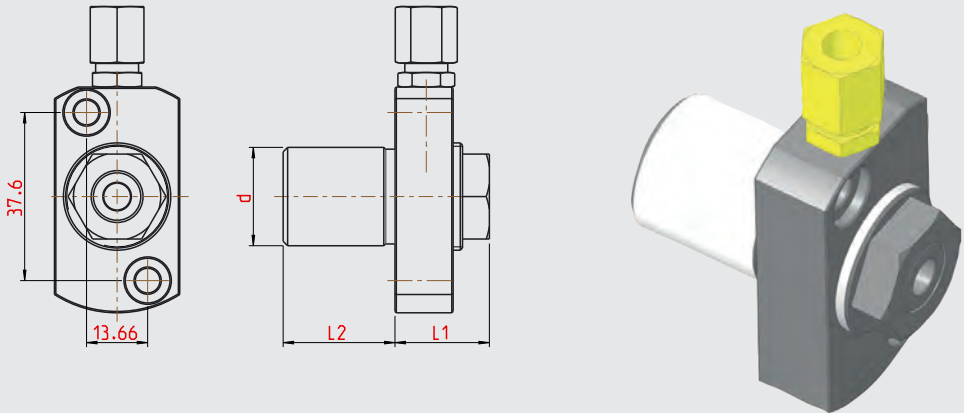

Art. Nummer Art. Number	Bezeichnung Description	d	l1	l2	d1	für Spannzange for collet
11-1179	GZ65.2224.16.S3.IM	22	21	25	22	ER16

Abmessungen in mm
Dimensions in mm

Ersatzteile / Spare parts

Art.-Nr:			
11-1179	004.00.19	001.00.14	62.610.16

Spannzangenhalter Typ GZ 51..
Chuck holder type GZ 51..

Lochbild S3
hole pattern S3

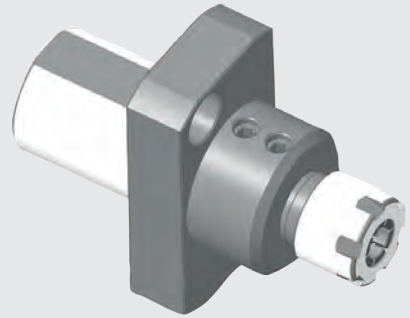
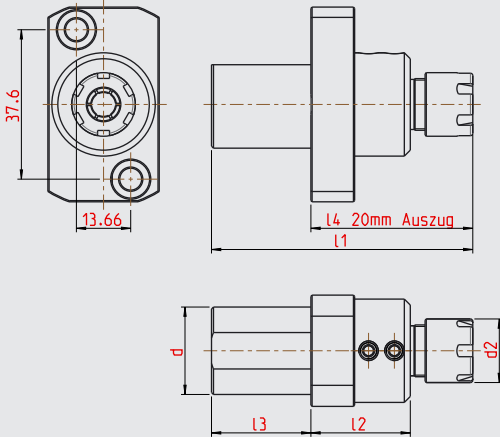

Art. Nummer Art. Number	Bezeichnung Description	d	l _{4 min}	l _{4 max}	l ₂	l ₃	d ₂	für Spannzeuge for collet
11-3201	GZ51.2225.11.S3	22	41	61	25	25	16	ER11
11-3204	GZ51.2225.16.S3	22	48	68	19	25	22	ER16

Abmessungen in mm
Dimensions in mm

Hinweis/Note:

Spannzangenhalter mit Längenverstellung, max. Auszug 20 mm
chuck holder with length adjustment, max. excerpt is 20mm

Ersatzteile / Spare parts

Art.-Nr:		
11-3201	001.00.99	62.000.11
11-3204	001.00.99	62.000.16

Bohrstangenhalter Typ BS 71.. Boring bar holder type BS 71..

Lochbild S3
hole pattern S3

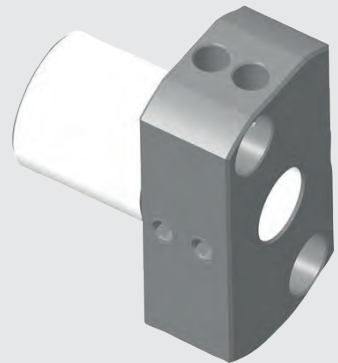
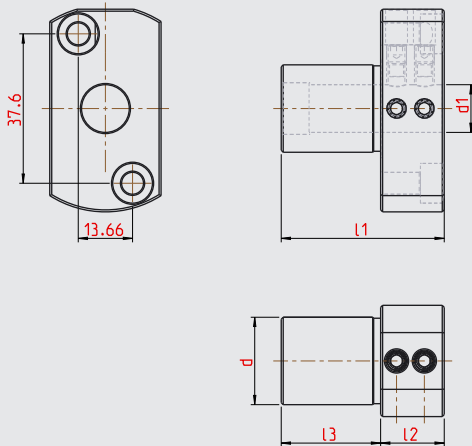

Art. Nummer Art. Number	Bezeichnung Description	d	d1	l1	l2	l3
11-0581	BS71.2225.12.S3	22	12	41	16	25
11-0646	BS71.2225.14.S3	22	14	41	16	25
11-0569	BS71.2225.16.S3	22	16	41	16	25

Abmessungen in mm
Dimensions in mm

Hinweis/Note:

ohne IK
no internal cooling

Ersatzteile / Spare parts



001.00.14

Bohrerhalter Typ BHE 73..
Drill holder type BHE 73..

Lochbild S3
hole pattern S3

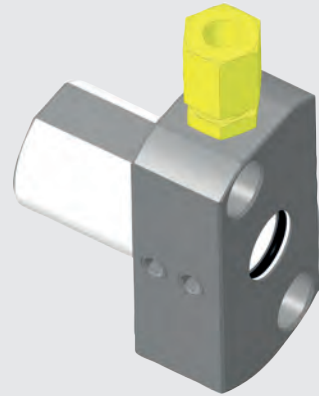
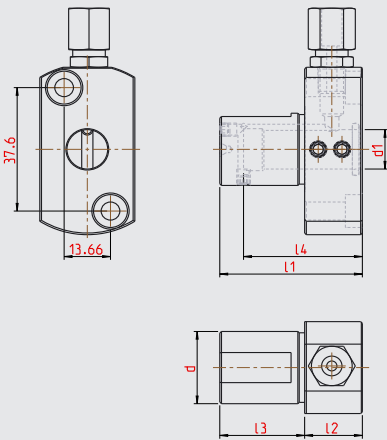

Art. Nummer Art. Number	Bezeichnung Description	d	d1	l1	l2	l3	l4
11-0741	BHE73.2225.06.S3	22	6	42	17	25	31
11-0742	BHE73.2225.08.S3	22	8	42	17	25	36
11-0442	BHE73.2225.10.S3	22	10	42	17	25	36
11-1156	BHE73.2225.10.S3.02	22	10	62	37	25	42
11-0994	BHE73.2225.12.S3	22	12	42	17	25	36
11-1281	BHE73.2225.12.S3.02	22	12	62	37	25	45
11-1296	BHE73.2225.14.S3	22	14	62	38	25	45
11-0546	BHE73.2225.16.S3	22	16	69	44	25	41

Abmessungen in mm
Dimensions in mm

Ersatzteile / Spare parts

Art.-Nr			
11-0741		001.00.14	002.00.112
11-0742		001.00.14	002.00.111
11-0442		001.00.14	002.00.110
11-1156	004.00.19	001.00.97	002.00.101
11-0994		001.00.14	002.00.109
11-1281		001.00.97	002.00.109
11-1296		001.00.97	002.00.156
11-0546		001.00.14	002.00.103

Gewindebohrerhalter Typ GB 68.. Square leaded tap holder type GB 68..

Lochbild S3
hole pattern S3

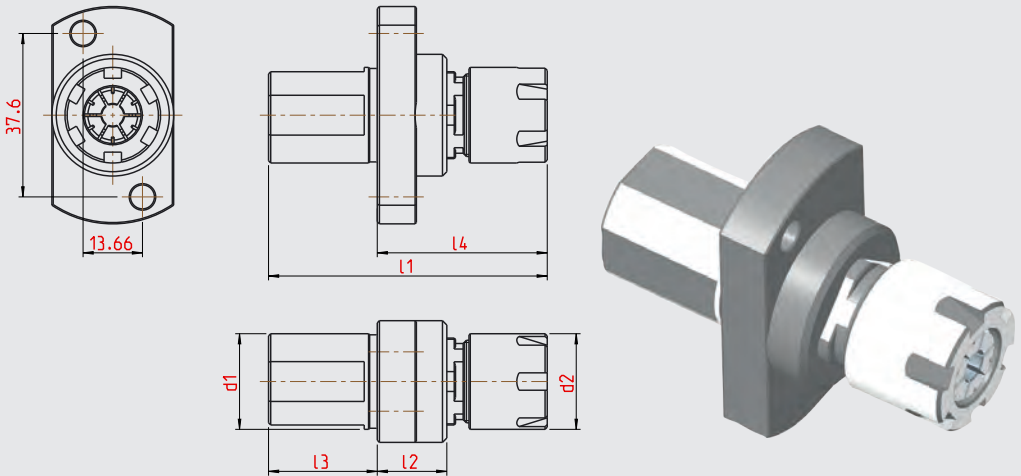

Art. Nummer Art. Number	Bezeichnung Description	d	l1	l2	l3	l4	d2	für Spannzange for cutting insert
11-0176	GB68.2225.11.S3	22	57	16	25	32	16	ER11
11-0177	GB68.2225.16.S3	22	64	16	25	39	22	ER16
11-0199	GB68.2225.20.S3	22	73	16	25	48	28	ER20

Hinweis/Note:

max. Auszug 7mm
max. excerpt is 7mm

Abmessungen in mm
Dimensions in mm

Ersatzteile / Spare parts

Art.-Nr:		
11-0176	6200011	001.00.14
11-0177	6200016	001.00.14
11-0199	6200020	001.00.14

Rückseitenhalter für HORN Schneideinsatz Typ 105..
Back working holder HORN insert type 105..

Lochbild S3
hole pattern S3

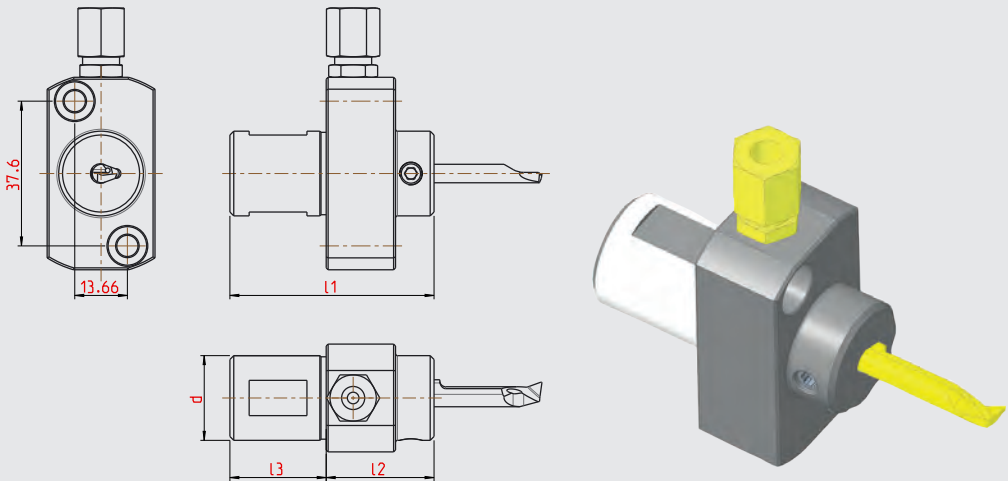



Ausführung rechtsschneidend, wie dargestellt · right cutting version as shown

Art. Nummer Art. Number	Bezeichnung Description	d	l1	l2	l3	für Schneideinsatz for insert
12-1386	RHF.N.226.H105.S3.IK	22	53	28	25	Horn Typ 105
12-1387	RHF.N.227.H105.S3.IK	22	65	40	25	Horn Typ 105
12-1388	RHF.N.228.H105.S3.IK	22	85	60	25	Horn Typ 105

Abmessungen in mm
Dimensions in mm

Ersatzteile / Spare parts

Art.-Nr:			
12-1386	001.01.36	004.00.19	001.00.07
12-1387	001.01.36	004.00.19	001.00.34
12-1388	001.01.36	004.00.19	001.00.11

Hinweis/Note:

IK Anschluss oben und unten
coolant connection at the top and down

Rückseitenhalter für HORN Schneideinsatz Typ 105.. Back working holder HORN insert type 105..

Lochbild S3
hole pattern S3

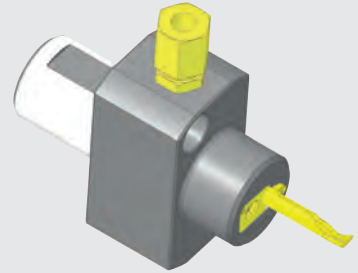
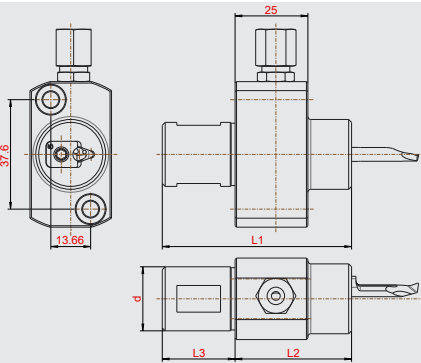





Art. Nummer Art. Number	Bezeichnung Description	d	l1	l2	l3	für Schneideinsatz for insert
12-1559	RHF.N.278.S.H105.S3.IK.03	22	53	28	25	Horn Typ 105, Größe 03
12-1560	RHF.N.278.S.H105.S3.IK.04	22	53	28	25	Horn Typ 105, Größe 04
12-1561	RHF.N.278.S.H105.S3.IK.05	22	53	28	25	Horn Typ 105, Größe 05
12-1563	RHF.N.279.S.H105.S3.IK.03	22	65	40	25	Horn Typ 105, Größe 03
12-1564	RHF.N.279.S.H105.S3.IK.04	22	65	40	25	Horn Typ 105, Größe 04
12-1565	RHF.N.279.S.H105.S3.IK.05	22	65	40	25	Horn Typ 105, Größe 05
12-1567	RHF.N.280.S.H105.S3.IK.03	22	85	60	25	Horn Typ 105, Größe 03
12-1568	RHF.N.280.S.H105.S3.IK.04	22	85	60	25	Horn Typ 105, Größe 04
12-1569	RHF.N.280.S.H105.S3.IK.05	22	85	60	25	Horn Typ 105, Größe 05

Abmessungen in mm
Dimensions in mm

Hinweis/Note:

Zur Bestimmung der Keilgröße, entnehmen Sie die Maße „b“ aus den HORN-Katalogen
To determine the wedge size, refer to the dimensions „b“ in the HORN catalogues

Ersatzteile / Spare parts

Für: For:				
RHF.N.278	004.00.19	002.00.170	001.00.07	435203/4/5
RHF.N.279	004.00.19	002.00.170	001.00.34	435203/4/5
RHF.N.280	004.00.19	002.00.170	001.00.11	435203/4/5

Pendelhalter
Floating holder

Lochbild S3
hole pattern S3

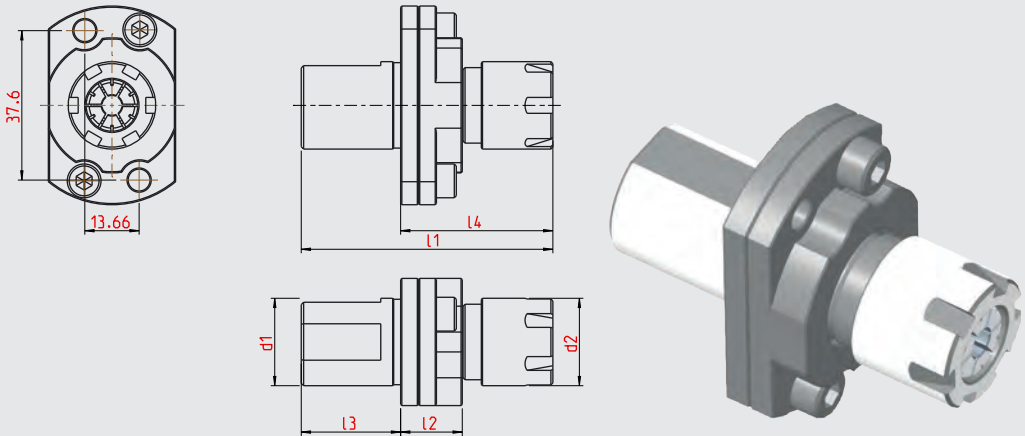

Art. Nummer Art. Number	Bezeichnung Description	d	l1	l2	l3	l4	d2	für Spannzange for collet
11-0193	GP70.2225.11.S3	22	58	15,5	25	33	16	ER11
11-0194	GP70.2225.16.S3	22	64	15,5	25	39	22	ER16

Abmessungen in mm
Dimensions in mm

Ersatzteile / Spare parts

Art.-Nr:		
11-0193	62.000.11	001.00.14
11-0194	62.000.16	001.00.14

Mehrkant-Drückgerät GDF Multi-sided equipment GDF

Lochbild S3 hole pattern S3

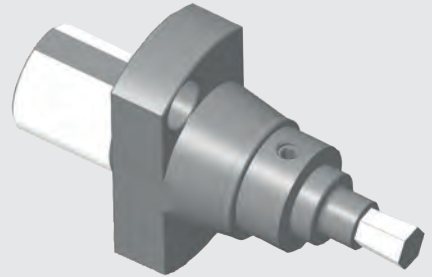
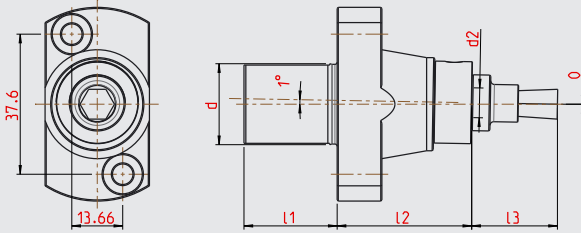

Art. Nummer Art. Number	Bezeichnung Description	d	l1	l2	l3	d2
11-3241	GDF76.2225.S3.08	22	25	25	23	8

Abmessungen in mm
Dimensions in mm

Ersatzteile / Spare parts



001.00.99

Rückseitenhalter für Schneidplatte TYP YW.. 11..
Back working holder for insert type YW.. 11..

Lochbild S3
hole pattern S3

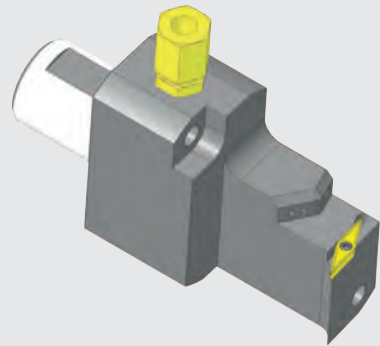
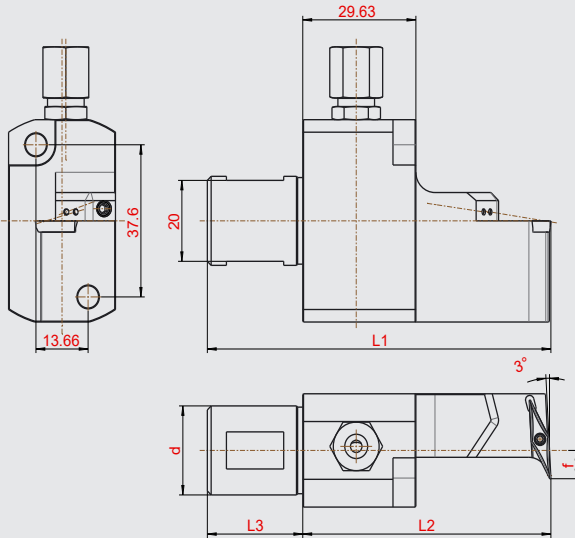

Ausführung rechtsschneidend, wie dargestellt · right cutting version as shown

Art. Nummer Art. Number	Bezeichnung Description	d	l1	l2	l3	f	für Schneidplatte for insert
12-1609	RHF.R.291.YW11.S3.IK	22	90	65	25	7	YW... 11...
12-1610	RHF.L.291.YW11.S3.IK	22	90	65	25	7	YW... 11...

Abmessungen in mm
Dimensions in mm

Hinweis/Note:

IK Anschluss oben und unten
coolant connection at the top and down

Ersatzteile / Spare parts

004.00.19	002.00.167	001.01.25	001.00.08
	002.00.170		

Gewindeschneideisenhalter Typ GS 69.. Screw threading holder type GS 69..

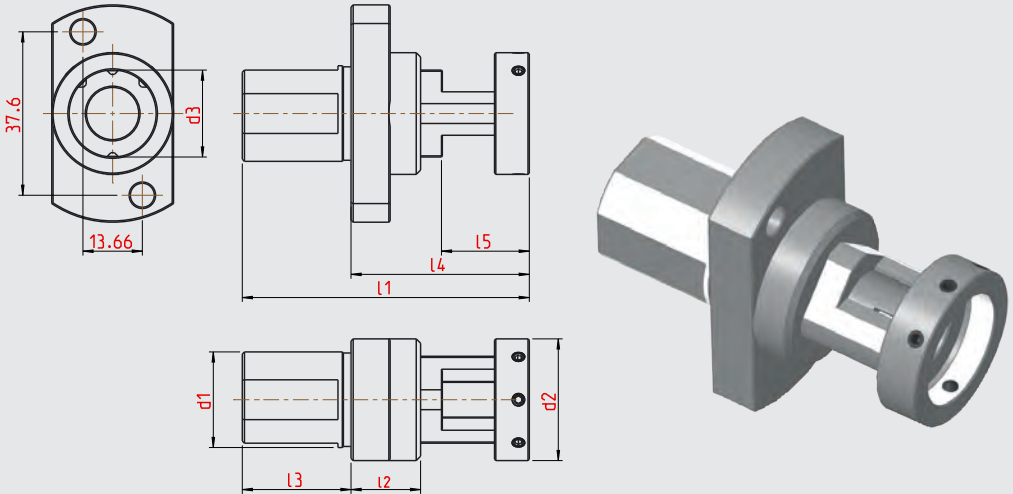

Lochbild S3 hole pattern S3



Art. Nummer Art. Number	Bezeichnung Description	d1	l1	l2	l3	l4	l5	d2	d3	b
11-0209	GS69.2225.1620.S3	22	56	16	25	31	20	24	16	5
11-1246	GS69.2225.1630.S3	22	66	16	25	41	30	24	16	5
11-0210	GS69.2225.2020.S3	22	56	16	25	31	20	28	20	6
11-0211	GS69.2225.2030.S3	22	66	16	25	41	30	28	20	6
11-0212	GS69.2225.2520.S3	22	60	16	25	35	22	33	25	8
11-0988	GS69.2225.2530.S3	22	70	16	25	45	32	33	25	8

Abmessungen in mm
Dimensions in mm

Ersatzteile / Spare parts

Art.-Nr:		
11-0209	002.00.48	001.00.14
11-1246	002.00.48	001.00.14
11-0210	002.00.48	001.00.14
11-0211	002.00.48	001.00.14
11-0212	002.00.48	001.00.14
11-0988	002.00.48	001.00.14

b = Schneideisenbreite
b = wide of cutting insert

Hinweis/Note:

max. Auszug 7mm
max. excerpt is 7mm

Zwischenstück
Plate between

Lochbild S3
hole pattern S3

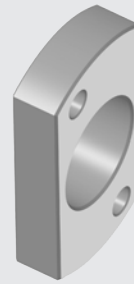
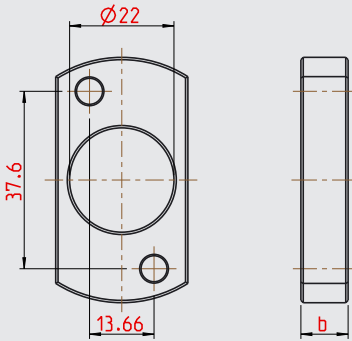

Art. Nummer Art. Number	Bezeichnung Description	b
12-1244	Z 2,5 S3	2,5
12-1243	Z 5 S3	5
12-1242	Z 10 S3	10
12-1377	Z 15 S3	15

Abmessungen in mm
Dimensions in mm

Hinweis/Note:

Zwischenstücke für Bohrbild S3
plate between for hole pattern S3

Zwischenstück Plate between

Lochbild S3
hole pattern S3

Technischer Hinweis/Note:

Anwendung von Zwischenstücken
Application from plate between

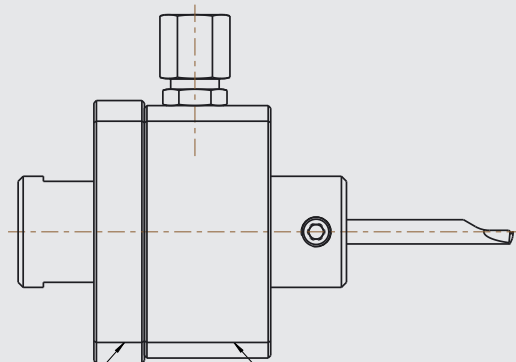
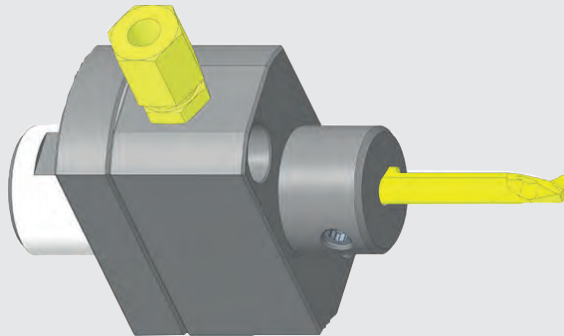

Zwischenstück Z ... S3
plate between

Einsatz RHF
holder RHF

Spannzangenhalter Typ GZ 65..
Holder type GZ 65..

Lochbild S4
hole pattern S4

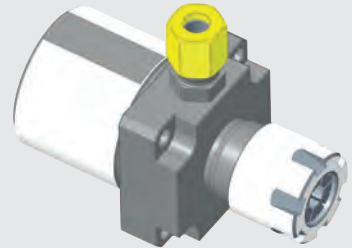
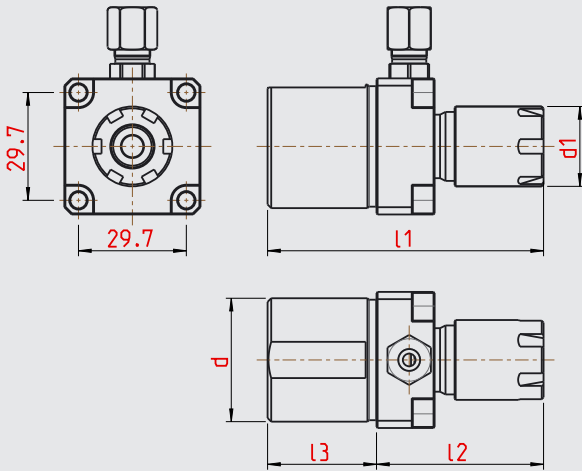

Art. Nummer Art. Number	Bezeichnung Description	d	l1	l2	l3	d1	für Spannzange for collet
12-1159	GZ65.3430.16.S4	34	76	46	30	22	ER16
12-3242	GZ65.3430.20.S4	34	80	50	30	28	ER20

Abmessungen in mm
Dimensions in mm

Ersatzteile / Spare parts

Art.-Nr:			
12-1159	004.00.19	001.00.142	62.00.16
12-3242	004.00.19	001.00.142	62.00.20

Hinweis/Note:

IK Anschluss oben und unten
coolant connection at the top and down

Abdichtbare Spannmutter
muß separat bestellt werden
Sealed chucking nut
must be ordered separately

Bohrerhalter Typ BHE 73.. Drill holder type BHE 73..

Lochbild S4
hole pattern S4

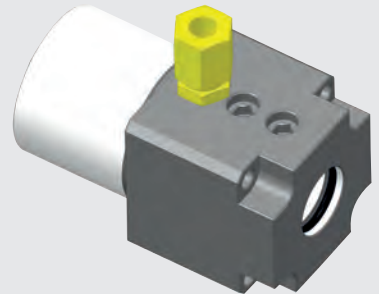
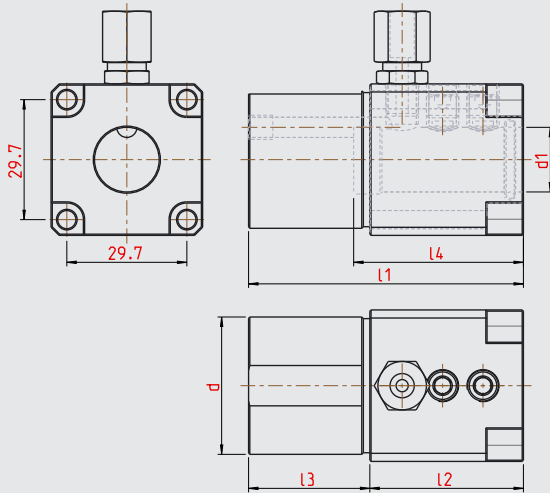

Art. Nummer Art. Number	Bezeichnung Description	d	d1	l1	l2	l3	l4
11-1161	BHE.73.3430.10.S4	34	10	68	38	30	42
11-1148	BHE.73.3430.16.S4	34	16	68	38	30	48
11-1149	BHE.73.3430.20.S4	34	20	68	38	30	50
11-1160	BHE.73.3430.25.S4	34	25	68	38	30	56

Abmessungen in mm
Dimensions in mm

Hinweis/Note:

IK Anschluss oben
coolant connection at the top

Ersatzteile / Spare parts



004.00.19

001.00.80

Rückseitenhalter für HORN Schneideinsatz Typ 105..
Back working holder HORN insert type 105..

Lochbild S4
hole pattern S4

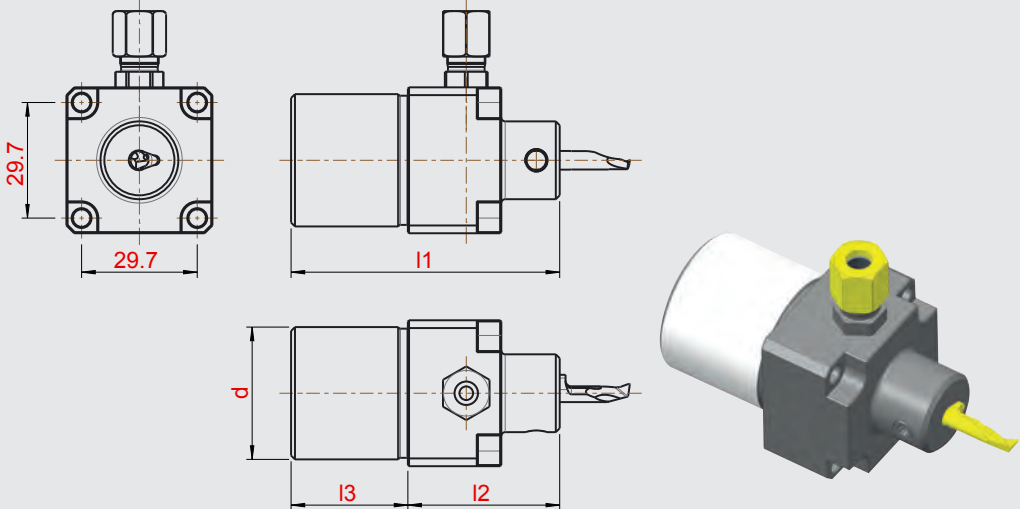

Art. Nummer Art. Number	Bezeichnung Description	d	l1	l2	l3	für Schneideinsatz for insert
12-1197	RHF.N.122.H105.S4.IK	34	69	39	30	Horn Typ 105

Abmessungen in mm
Dimensions in mm

Hinweis/Note:

IK Anschluss oben und unten
coolant connection at the top and down

Ersatzteile / Spare parts



001.01.36 004.00.19 001.00.142

Rückseitenhalter für HORN Schneideinsatz Typ 105.. Back working holder HORN insert type 105..

Lochbild S4
hole pattern S4

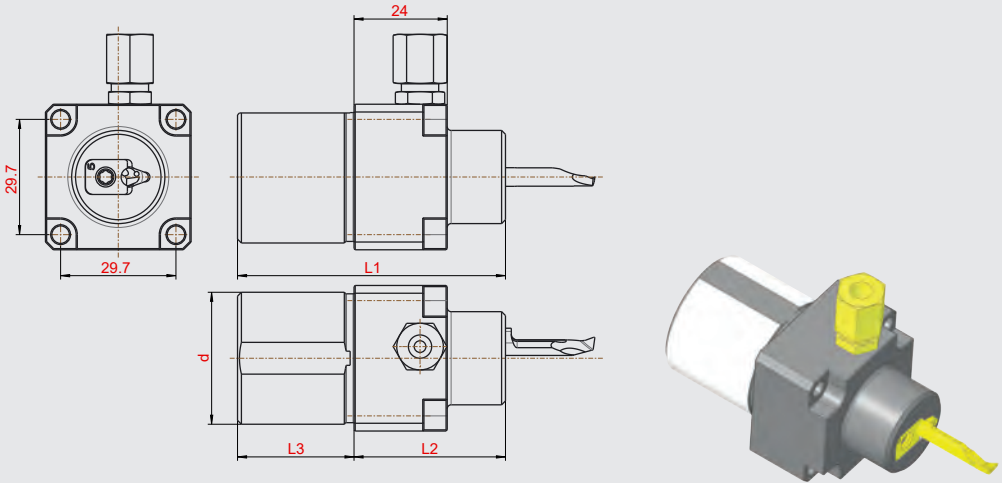





Art. Nummer Art. Number	Bezeichnung Description	d	l1	l2	l3	für Schneideinsatz for insert
12-1555	RHF.N.277.S.H105.S4.IK.03	34	69	39	30	Horn Typ 105, Größe 03
12-1556	RHF.N.277.S.H105.S4.IK.04	34	69	39	30	Horn Typ 105, Größe 04
12-1557	RHF.N.277.S.H105.S4.IK.05	34	69	39	30	Horn Typ 105, Größe 05

Abmessungen in mm
Dimensions in mm

Hinweis/Note:

Zur Bestimmung der Keilgröße, entnehmen Sie die Maße „b“ aus den HORN-Katalogen
To determine the wedge size, refer to the dimensions „b“ in the HORN catalogues

Ersatzteile / Spare parts

			
004.00.19	002.00.170	001.00.34	435203
004.00.19	002.00.170	001.00.34	435204
004.00.19	002.00.170	001.00.34	435205

Rückseitenhalter für Schneidplatte TYP HORN 110..
Back working holder for insert type HORN 110..

Lochbild S4
hole pattern S4

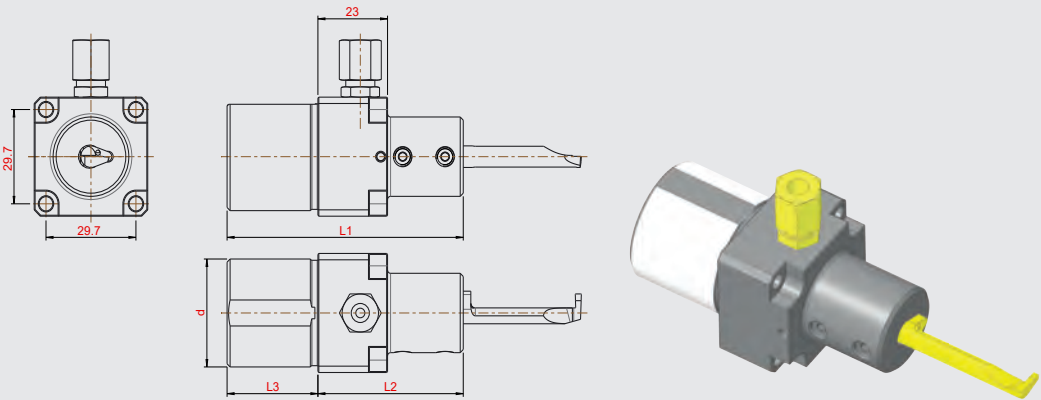



Art. Nummer Art. Number	Bezeichnung Description	d	l1	l2	l3	f	für Schneideinsatz for insert
12-1434	RHF.N.241.H110.S4.IK	34	78	48	30	4	HORN Typ 110

Abmessungen in mm
Dimensions in mm

Hinweis/Note:

IK Anschluss oben und unten
coolant connection at the top and down

Ersatzteile / Spare parts

		
004.00.19	002.00.36	001.00.142
	002.00.170	

Rückseitenhalter für Schneidplatte Typ DC..11..

Back working holder for insert type DC..11..

Lochbild S4
hole pattern S4

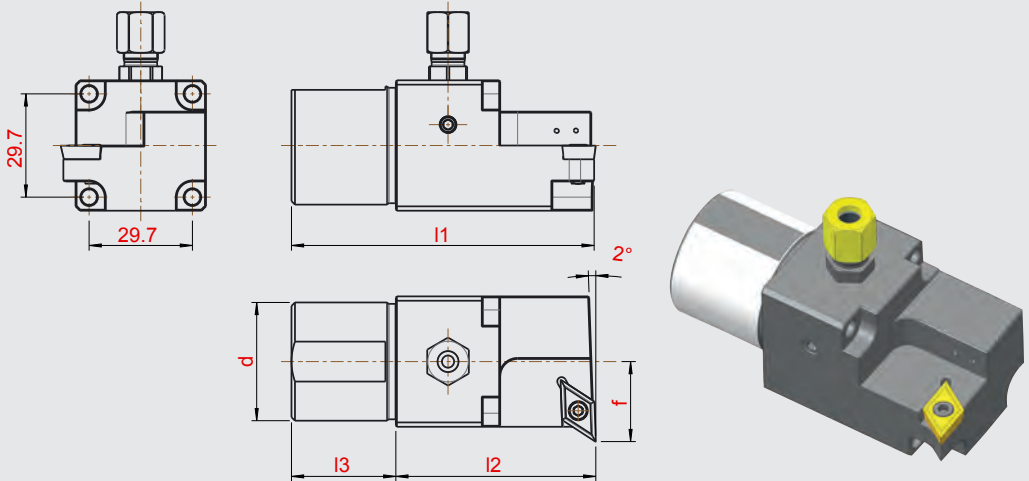

Ausführung rechtsschneidend, wie dargestellt · right cutting version as shown



Art. Nummer Art. Number	Bezeichnung Description	d	l1	l2	l3	f	für Schneidplatte for insert
12-1155	RHF.R.120.DC11.S4.IK	34	88	58	30	23	DC...11...
12-1196	RHF.L.120.DC11.S4.IK	34	88	58	30	23	DC...11...

Abmessungen in mm
Dimensions in mm

Hinweis/Note:

IK Anschluss oben und unten
coolant connection at the top and down

Ersatzteile / Spare parts

		
001.01.15	004.00.19	001.00.08
		001.00.30

Rückseitenhalter für Schneidplatte DC.. 11..
Back working holder for insert type DC.. 11..

Lochbild S4
hole pattern S4

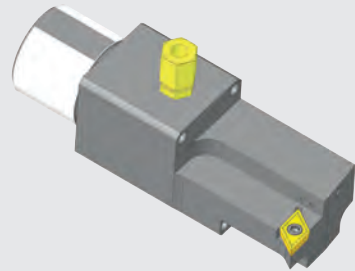
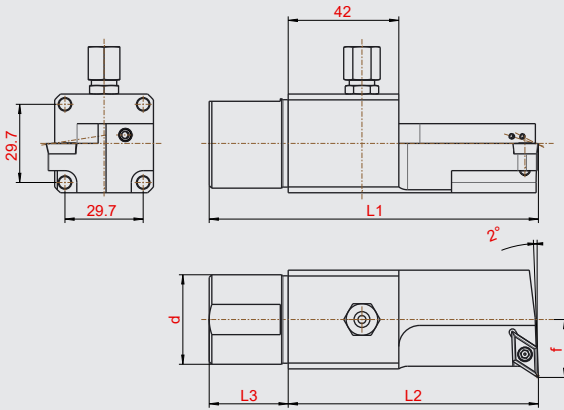

Ausführung rechtsschneidend, wie dargestellt · right cutting version as shown



Art. Nummer Art. Number	Bezeichnung Description	d	l1	l2	l3	f	für Schneidplatte for insert
12-1418	RHF.R.237.DC11.S4.IK	34	125	95	30	22	DC.. 11..
12-1419	RHF.L.237.DC11.S4.IK	34	125	95	30	22	DC.. 11..

Abmessungen in mm
Dimensions in mm

Hinweis/Note:

IK Anschluss oben und unten
coolant connection at the top and down

Ersatzteile / Spare parts

		
004.00.19	002.00.168	001.01.15
	002.00.170	

Rückseitenhalter für Schneidplatte Typ VC..11.. Back working holder for insert type VC..11..

Lochbild S4
hole pattern S4

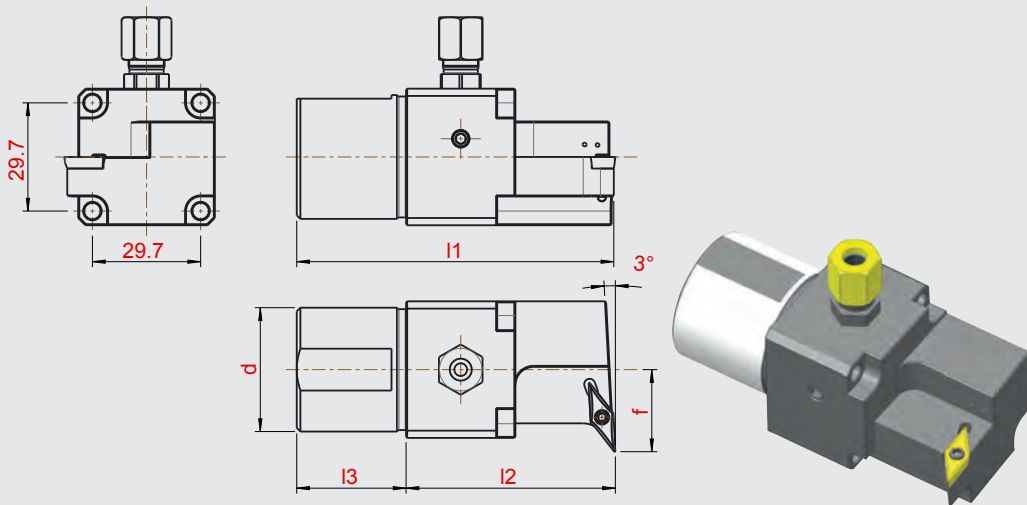

Ausführung rechtsschneidend, wie dargestellt · right cutting version as shown

Art. Nummer Art. Number	Bezeichnung Description	d	l1	l2	l3	f	für Schneidplatte for insert
12-1199	RHF.R.121.VC11.S4.IK	34	87,5	57,5	30	22,5	VC...11...
12-1200	RHF.L.121.VC11.S4.IK	34	87,5	57,5	30	22,5	VC...11...

Abmessungen in mm
Dimensions in mm

Hinweis/Note:

IK Anschluss oben und unten
coolant connection at the top and down

Ersatzteile / Spare parts

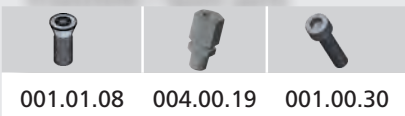

Rückseitenhalter für Schneidplatte VC.. 11..
Back working holder for insert type VC.. 11..

Lochbild S4
hole pattern S4

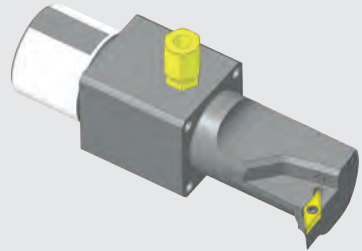
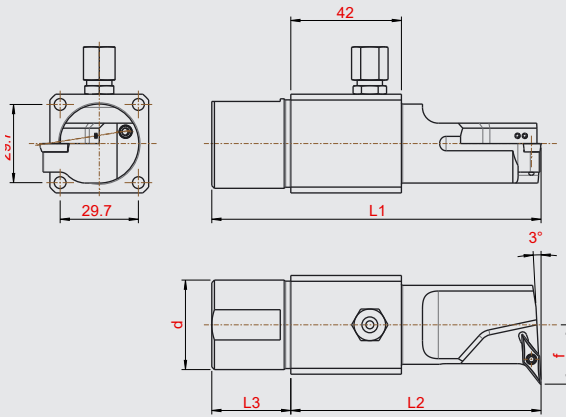

Ausführung rechtsschneidend, wie dargestellt · right cutting version as shown



Art. Nummer Art. Number	Bezeichnung Description	d	l1	l2	l3	f	für Schneidplatte for insert
12-1420	RHF.R.238.VC11.S4.IK	34	125	95	30	22,5	VC.. 11..
12-1421	RHF.L.238.VC11.S4.IK	34	125	95	30	22,5	VC.. 11..

Abmessungen in mm
Dimensions in mm

Hinweis/Note:

IK Anschluss oben und unten
coolant connection at the top and down

Ersatzteile / Spare parts

		
004.00.19	002.00.168	001.01.08
	002.00.170	

Rückseitenhalter für Schneidplatte YW.. 11.. Back working holder for insert type YW.. 11..

Lochbild S4
hole pattern S4

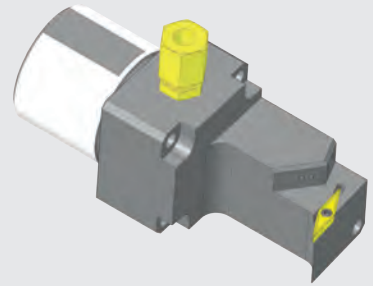
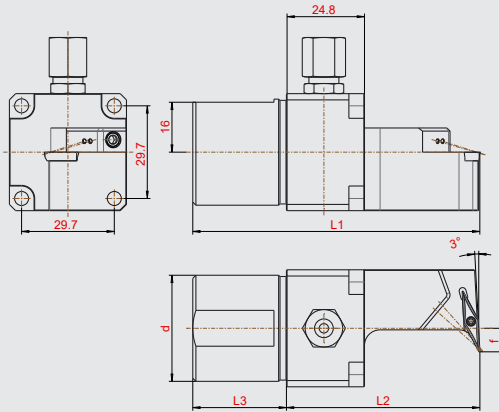

Ausführung rechtsschneidend, wie dargestellt · right cutting version as shown

Art. Nummer Art. Number	Bezeichnung Description	d	l1	l2	l3	f	für Schneidplatte for insert
12-1611	RHF.R.292.YW11.S4.IK	34	92	62	30	7,5	YW.. 11..
12-1612	RHF.L.292.YW11.S4.IK	34	92	62	30	7,5	YW.. 11..

Abmessungen in mm
Dimensions in mm

Hinweis/Note:

IK Anschluss oben und unten
coolant connection at the top and down

Ersatzteile / Spare parts

			
004.00.19	002.00.168	001.01.25	001.00.142
	002.00.170		

Rückseitenhalter für Schneidplatte Typ CC 09..
Back working holder for insert type CC 09..

Lochbild S4
hole pattern S4

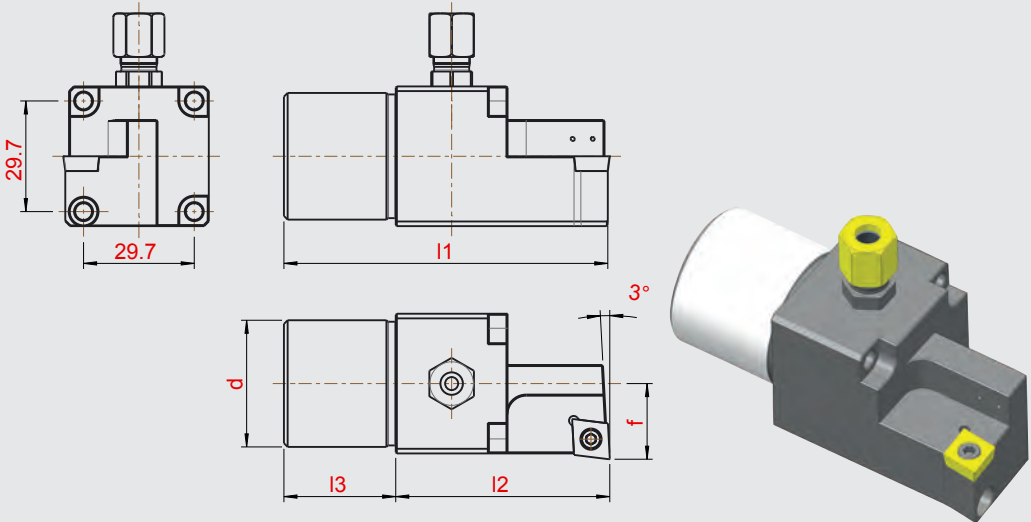

Ausführung rechtsschneidend, wie dargestellt · right cutting version as shown



Art. Nummer Art. Number	Bezeichnung Description	d	l1	l2	l3	f	für Schneidplatte for insert
12-1203	RHF.R.127.CC09.S4.IK	34	87,5	57,5	30	20,5	CC...09...
12-1204	RHF.L.127.CC09.S4.IK	34	87,5	57,5	30	20,5	CC...09...

Abmessungen in mm
Dimensions in mm

Hinweis/Note:

IK Anschluss oben und unten
coolant connection at the top and down

Ersatzteile / Spare parts

		
001.01.15	004.00.19	001.00.143
		001.00.55

Rückseitenhalter für Schneidplatte Typ GRAF G.0004

Back working holder for insert type GRAF G.0004

Lochbild S4
hole pattern S4

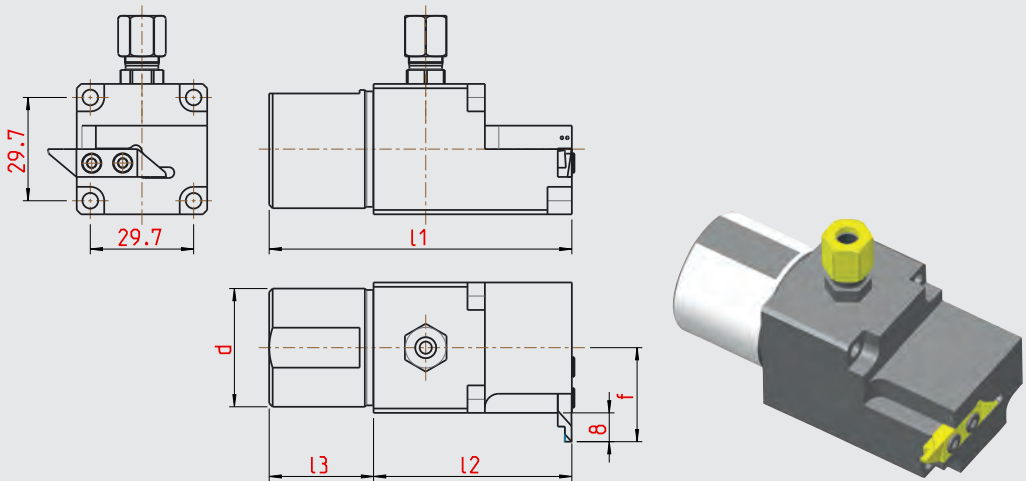

Ausführung rechtsschneidend, wie dargestellt · right cutting version as shown



Art. Nummer Art. Number	Bezeichnung Description	d	l1	l2	l3	f	für Schneidplatte for insert
12-1205	RHF.R.124.G0004.S4.IK	34	87	57	30	27	G0004
12-1206	RHF.L.124.G0004.S4.IK	34	87	57	30	27	G0004

Abmessungen in mm
Dimensions in mm

Hinweis/Note:

IK Anschluss oben und unten
coolant connection at the top and down

Ersatzteile / Spare parts

		
001.01.15	004.00.19	001.00.143
		001.00.144

Rückseitenhalter für Schneidplatte Typ HORN S274
Back working holder for insert type HORN S274

Lochbild S4
hole pattern S4

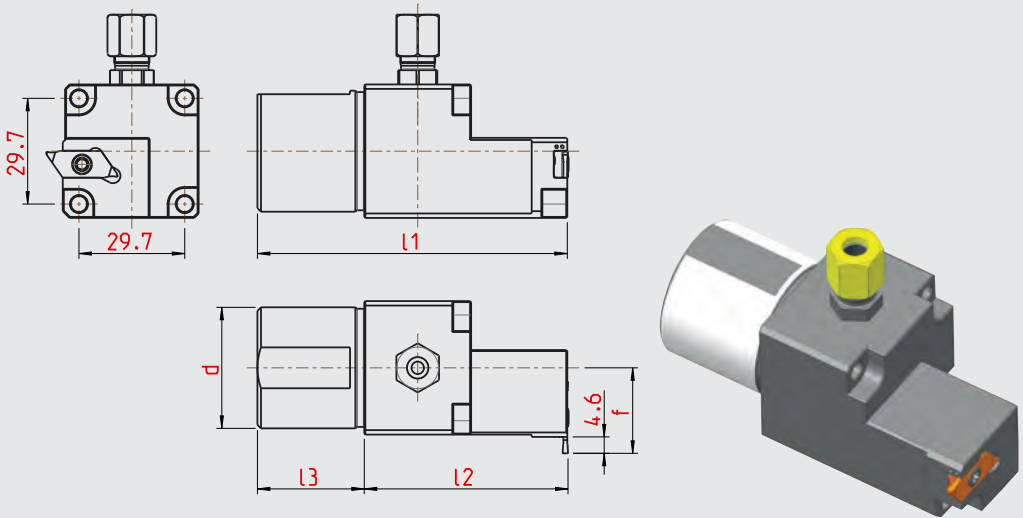

Ausführung rechtsschneidend, wie dargestellt · right cutting version as shown



Art. Nummer Art. Number	Bezeichnung Description	d	l1	l2	l3	f	für Schneidplatte for insert
12-1207	RHF.R.129.S274.S4.IK	34	87	57	30	24	Horn Typ S274
12-1208	RHF.L.129.S274.S4.IK	34	87	57	30	24	Horn Typ S274

Abmessungen in mm
Dimensions in mm

Hinweis/Note:

IK Anschluss oben und unten
coolant connection at the top and down

Ersatzteile / Spare parts

		
001.01.15	004.00.19	001.00.144
		001.00.09

Rückseitenhalter für Schneidplatte HORN TYP S274 Back working holder for insert type HORN TYP S274

Lochbild S4
hole pattern S4

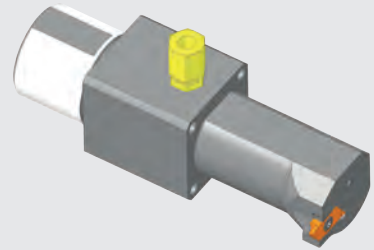
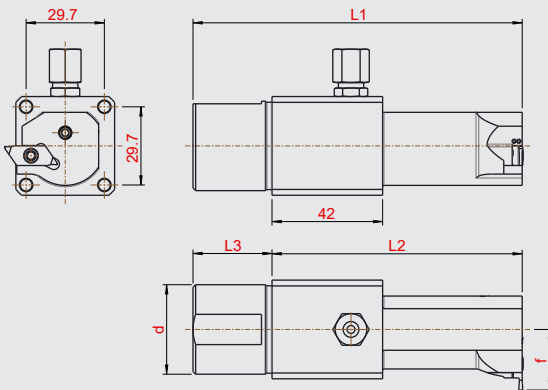

Ausführung rechtsschneidend, wie dargestellt · right cutting version as shown



Art. Nummer Art. Number	Bezeichnung Description	d	I1	I2	I3	f	für Schneidplatte for insert
12-1422	RHF.R.239.S274.S4.IK	34	125	95	30	23	HORN Typ S274
12-1423	RHF.L.239.S274.S4.IK	34	125	95	30	23	HORN Typ S274

Abmessungen in mm
Dimensions in mm

Hinweis/Note:

IK Anschluss oben und unten
coolant connection at the top and down

Ersatzteile / Spare parts

		
004.00.19	002.00.167	001.01.39
	002.00.168	
	002.00.170	

Rückseitenhalter für Schneidplatte Typ 16 ER/EL..
Back working holder for insert type 16 ER/EL..

Lochbild S4
hole pattern S4

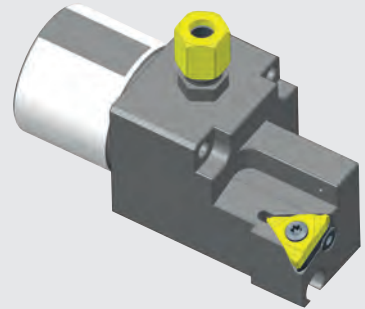
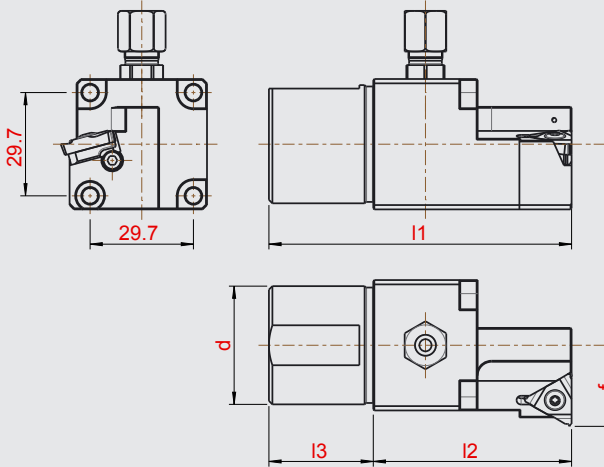

Ausführung rechtsschneidend, wie dargestellt · right cutting version as shown



Art. Nummer Art. Number	Bezeichnung Description	d	l1	l2	l3	f	für Schneidplatte for insert
12-1201	RHF.R.128.16ER.S4.IK	34	87	57	30	23,5	16ER
12-1202	RHF.L.128.16EL.S4.IK	34	87	57	30	23,5	16EL

Abmessungen in mm
Dimensions in mm

Hinweis/Note:

IK Anschluss oben und unten
coolant connection at the top and down

Ersatzteile / Spare parts

		
001.01.65	004.00.19	001.00.144
		001.00.09

Berechnung Steigungswinkel
auf Seite 125-126.
Calculation helix angles on page 125-126.

Rückseitenhalter für Vierkantschaft Back working holder for square shank

Lochbild S4
hole pattern S4

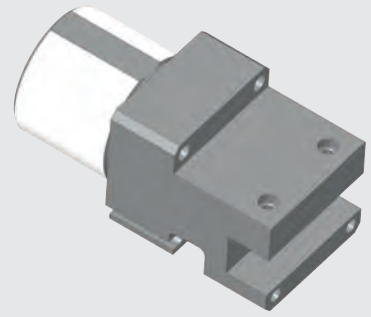
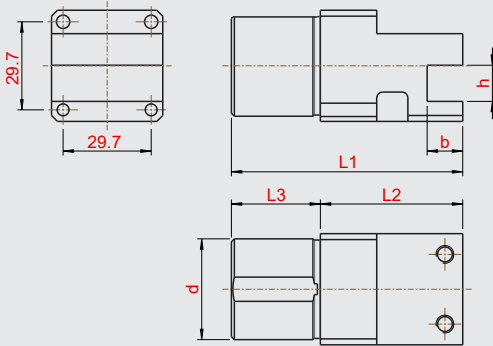

Art. Nummer Art. Number	Bezeichnung Description	d	l1	l2	l3	b	h
12-1516	RHF.N.262.1212.S4	34	78	48	30	12	12

Abmessungen in mm
Dimensions in mm

Ersatzteile / Spare parts

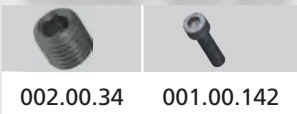

002.00.34

001.00.142

Rückseitenhalter für Schneidplatte TYP DC.. 07..
Back working holder for insert type TYP DC.. 07..

Lochbild S5
hole pattern S5

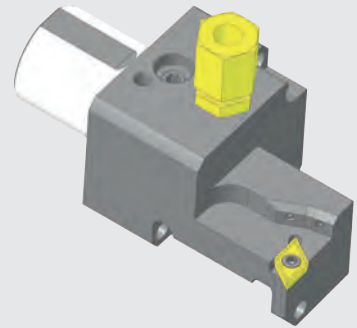
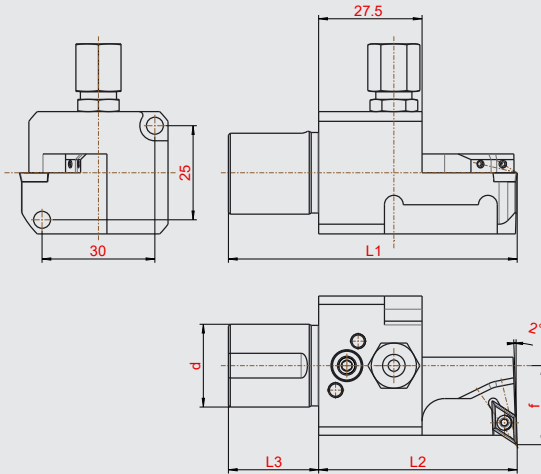

Ausführung rechtsschneidend, wie dargestellt · right cutting version as shown



Art. Nummer Art. Number	Bezeichnung Description	d	l1	l2	l3	f	für Schneidplatte for insert
12-1505	RHF.R.259.DC07.S5.IK	22	77	53	24	21	DC.. 07..
12-1506	RHF.L.259.DC07.S5.IK	22	77	53	24	21	DC.. 07..

Abmessungen in mm
Dimensions in mm

Hinweis/Note:

IK Anschluss oben und unten
coolant connection at the top and down

Ersatzteile / Spare parts

		
004.00.19	002.00.168	001.01.01
	002.00.170	

Rückseitenhalter für Schneidplatte YW.. 11..

Back working holder for insert type YW.. 11..

Lochbild S5
hole pattern S5

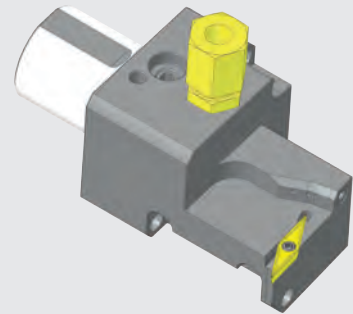
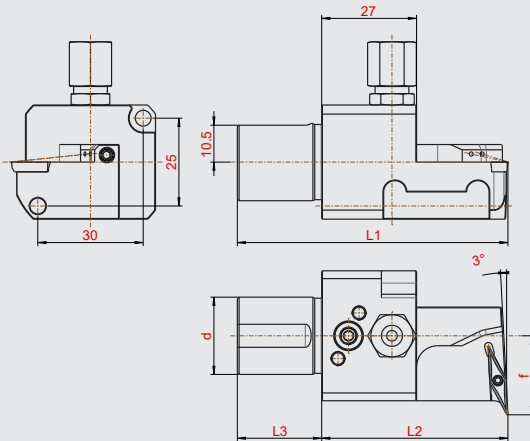

Ausführung rechtsschneidend, wie dargestellt · right cutting version as shown





Art. Nummer Art. Number	Bezeichnung Description	d	l1	l2	l3	f	für Schneidplatte for insert
12-1613	RHF.R.293.YW11.S5.IK	22	77	53	24	22,5	YW.. 11..
12-1614	RHF.L.293.YW11.S5.IK	22	77	53	24	22,5	YW.. 11..

Abmessungen in mm
Dimensions in mm

Hinweis/Note:

IK Anschluss oben und unten
coolant connection at the top and down

Ersatzteile / Spare parts

			
004.00.19	002.00.167	001.01.25	001.00.142
	002.00.168		
	002.00.170		

Rückseitenhalter für Schneidplatte TYP 16ER / 16EL
Back working holder for insert type TYP 16ER / 16EL

Lochbild S5
hole pattern S5

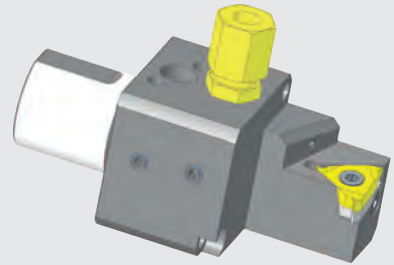
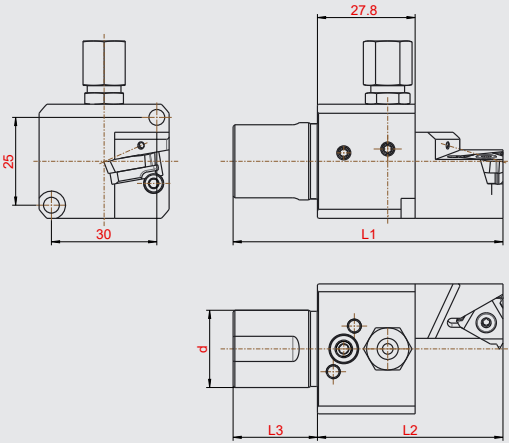

Ausführung rechtsschneidend, wie dargestellt · right cutting version as shown



Art. Nummer Art. Number	Bezeichnung Description	d	I1	I2	I3	für Schneidplatte for insert
12-1507	RHF.R.260.16ER.S5.IK	22	77	53	24	16ER
12-1508	RHF.L.260.16ER.S5.IK	22	77	53	24	16EL

Abmessungen in mm
Dimensions in mm

Hinweis/Note:

IK Anschluss oben und unten
coolant connection at the top and down

Ersatzteile / Spare parts

		
004.00.19	002.00.167	001.01.65
	002.00.168	
	002.00.170	

Berechnung Steigungswinkel
auf Seite 125-126.
Calculation helix angles on page 125-126.

Dreifach Rückseitenhalter mit Innenkühlung Triple Back working holder with internal cooling

für STAR SR20 RIV
for STAR SR20 RIV

Art.Nr.: 4.253.00

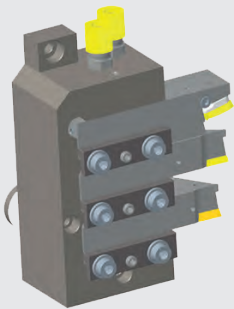
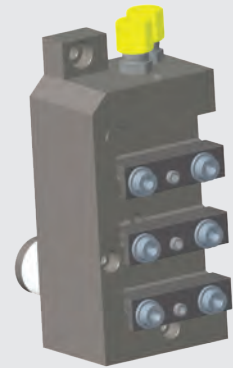
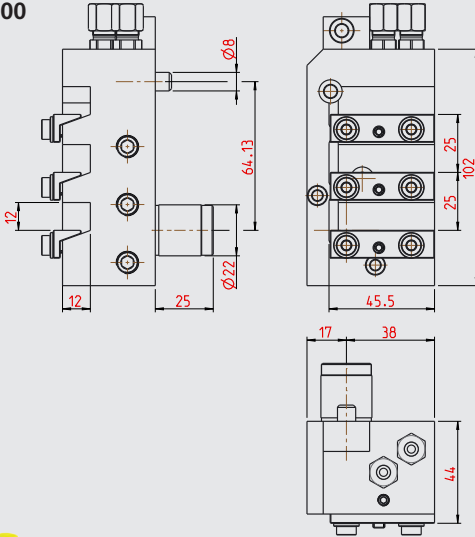



Halter werden Überkopf eingesetzt
Innenkühlung durch den Halter

facing up processing
inner cooling through the holder

Hinweis/Note:

Wendepplattenhalter müssen separat bestellt werden.
Turret plate holder must be ordered separately.

Ersatzteile / Spare parts

		
004.00.19	001.00.30	4.253.03
	001.00.108	

Dreifach Rückseitenhalter mit Innenkühlung
Triple Back working holder with internal cooling

für STAR SR32
for STAR SR32

Art.Nr.: 4.335.00

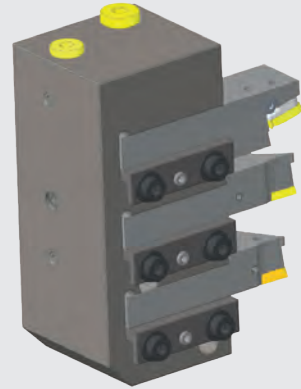
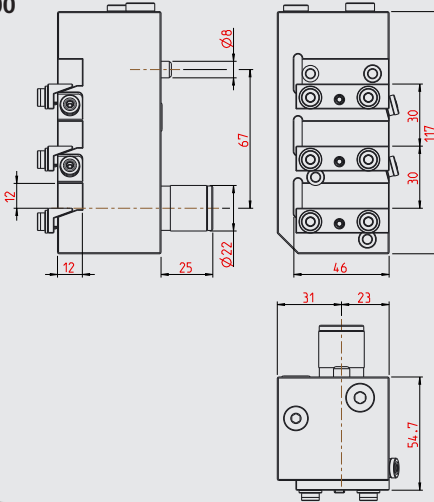

Halter werden Überkopf eingestzt
Innenkühlung durch den Halter

facing up processing
inner cooling through the holder

Hinweis/Note:

Wendeplattenhalter müssen separat bestellt werden.
Turret plate holder must be ordered separately.

Ersatzteile / Spare parts



004.00.19

001.00.108

4.253.03

Dreifach Rückseitenhalter mit Innenkühlung

Triple Back working holder with internal cooling

für STAR SR38
for STAR SR38

Art.Nr.: 4.270.00

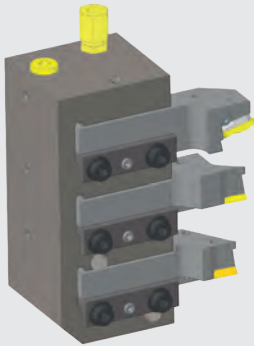
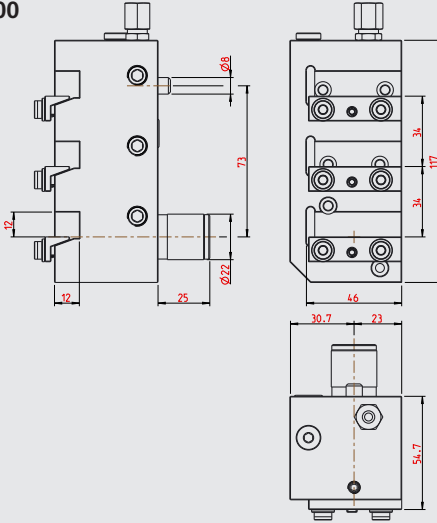

Halter werden Überkopf eingesetzt
Innenkühlung durch den Halter

facing up processing
inner cooling through the holder

Hinweis/Note:

Wendeplattenhalter müssen separat bestellt werden.
Turret plate holder must be ordered separately.

Ersatzteile / Spare parts



004.00.19

001.00.108

4.253.03

Wendeplattenhalter für Dreifach-Rückseitenhalter
Turret plate holder for triple back working tool holder

Wendeplattenhalter mit Innenkühlung
Turret plate holder with internal cooling

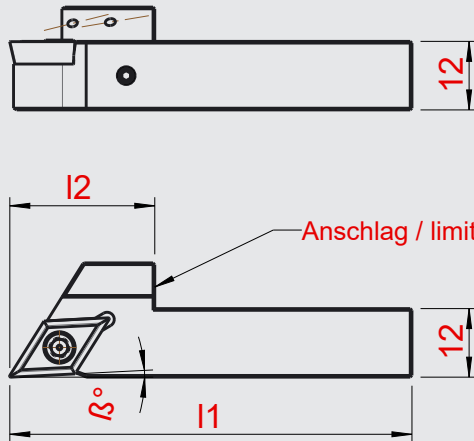
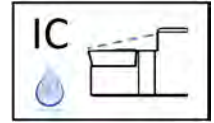

Ausführung rechtsschneidend, wie dargestellt · right cutting version as shown

Art. Nummer Art. Number	Bezeichnung Description	β	l1	l2	für Wendschneidplatte for cutting insert
01-1387	SCJC.R.1212.E09.IK	3°	70	25	CC.. 09 T3 ..
01-1386	SDJC.R.1212.E11.IK	3°	70	25	DC.. 11 T3 ..
01-1388	SVJC.R.1212.E11.IK	3°	75	30	VC.. 11 03 ..
01-1390	SER.1212.F16.IK	0°	80	35	16 ER ..



Abmessungen in mm
Dimensions in mm

Ersatzteile / Spare parts

Art.-Nr:	
01-1387	001.01.15
01-1386	001.01.15
01-1388	001.01.08
01-1390	001.01.65

Wendeplattenhalter für Dreifach-Rückseitenhalter Turret plate holder for triple back working tool holder

Wendeplattenhalter mit Innenkühlung
Turret plate holder with internal cooling

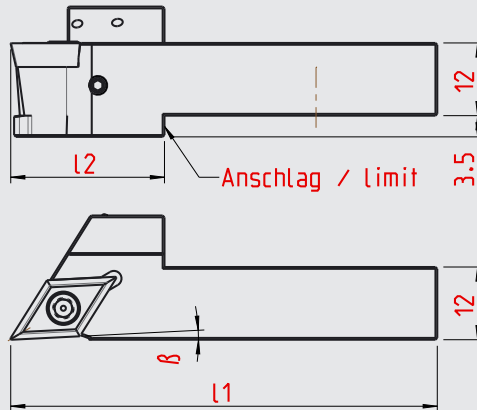

Ausführung rechtsschneidend, wie dargestellt · right cutting version as shown

Art. Nummer Art. Number	Bezeichnung Description	β	l1	l2	für Wendschneidplatte for cutting insert
01-1392	SCJC.R.1212.E09.2IK	3°	70	25	CC.. 09 T3 ..
01-1391	SDJC.R.1212.E11.2IK	3°	70	25	DC.. 11 T3 ..
01-1393	SVJC.R.1212.E11.2IK	3°	75	30	VC.. 11 03 ..
01-1477	SYJC.R.1212.E11.2IK	3°	75	30	YW.. 11..



Abmessungen in mm
Dimensions in mm

Ersatzteile / Spare parts

Art.-Nr:	
01-1392	001.01.15
01-1391	001.01.15
01-1393	001.01.08
01-1477	001.01.25

Wendeplattenhalter für Dreifach-Rückseitenhalter
Turret plate holder for triple back working tool holder

Wendeplattenhalter abgesetzt mit Innenkühlung
Turret plate holder with internal cooling

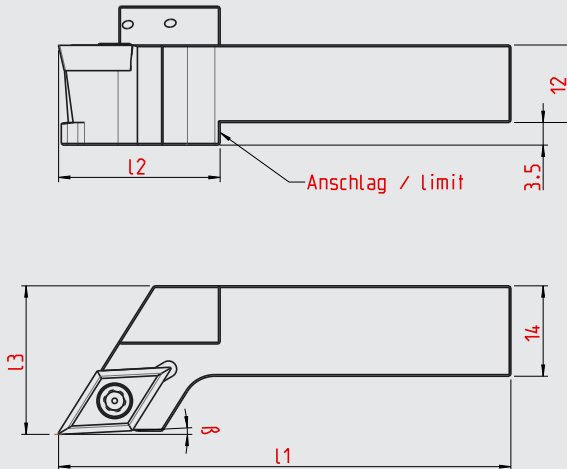

Ausführung rechtsschneidend, wie dargestellt · right cutting version as shown

Art. Nummer Art. Number	Bezeichnung Description	β	l1	l2	l3	für Wendschneidplatte for cutting insert
01-1377	SCJC.R.1214.E09.2IK.AN9	3°	70	25	23	CC.. 09 T3 ..
01-1376	SDJC.R.1214.E11.2IK.AN9	3°	70	25	23	DC.. 11 T3 ..
01-1378	SVJC.R.1214.E11.2IK.AN9	3°	75	30	23	VC.. 11 03 ..
01-1379	SER.1214.F16.IK.AN9	0°	80	35	23	16 ER ..
01-1478	SYJC.R.1214.E11.2IK.AN9	3°	75	30	23	YW.. 11..



Ersatzteile / Spare parts

Art.-Nr:	
01-1387	001.01.15
01-1386	001.01.15
01-1388	001.01.08
01-1390	001.01.65
01-1478	001.01.25

Abmessungen in mm
Dimensions in mm

Größenzuordnung Spannkeil für HORN Typ 105

Sizing wedge for HORN type 105



Größe 3 (HWS = 105123)
Size 3

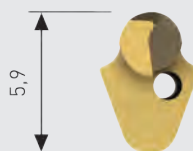

Größe 4 (HWS = 105124)
Size 4

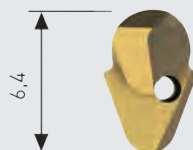

Größe 5 (HWS = 105125)
Size 5



Technischer Hinweis/Note:

Keilgröße HORN Typ 105 / wedge size HORN type 105
Bestellnummer entnehmen Sie aus den HORN-Katalogen
Order number please refer to the HORN-catalogues

Berechnung des Steigungswinkel β

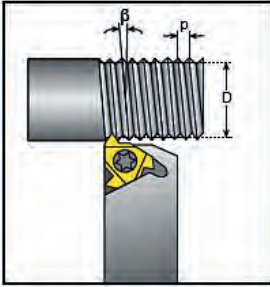

Der Steigungswinkel wird mit folgender Formel berechnet:

$$\beta = \arctan \frac{P \times N}{\pi \times D}$$

β - Steigungswinkel [°]
 P - Teilung [mm]
 N - Anzahl der Gänge
 D - Flankendurchmesser [mm]
 Steigung L = P x N

Der Steigungswinkel kann ebenfalls aus dem untenstehenden Diagramm abgelesen werden.

Steigungswinkeldiagramm

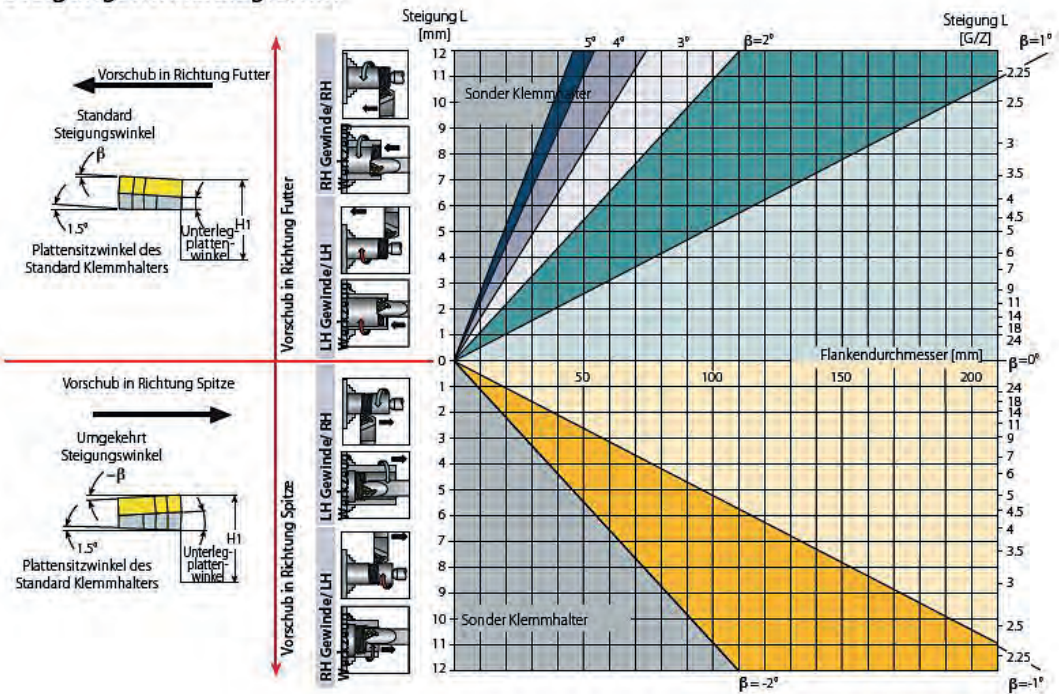

Resultierender Steigungswinkel		4,5°	3,5°	2,5°	1,5°	0,5°	0°	-0,5°	-1,5°
Plattengröße 16 mm	Plattenwinkel	3°P	2°P	1°P	0°	1°N	1,5°N	2°N	3°N
	Artikelnummer R	002.00.186	002.00.181	002.00.182	002.00.180	002.00.183	002.00.187	002.00.184	002.00.185
	Artikelnummer L	002.00.196	002.00.191	002.00.192	002.00.190	002.00.193	002.00.197	002.00.194	002.00.195

Calculating the Helix Angle β

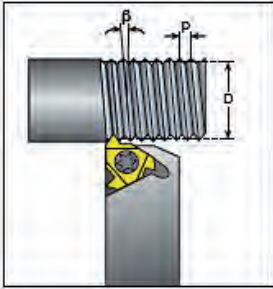

The helix angle is calculated by the following formula:

$$\beta = \arctan \frac{P \times N}{\pi \times D}$$

β - Helix angle [°]
 P - Pitch [mm]
 N - No. of starts
 D - Pitch diameter [mm]
 Lead = P x N

The helix angle can also be found from the diagram below.

Helix Angle Diagram

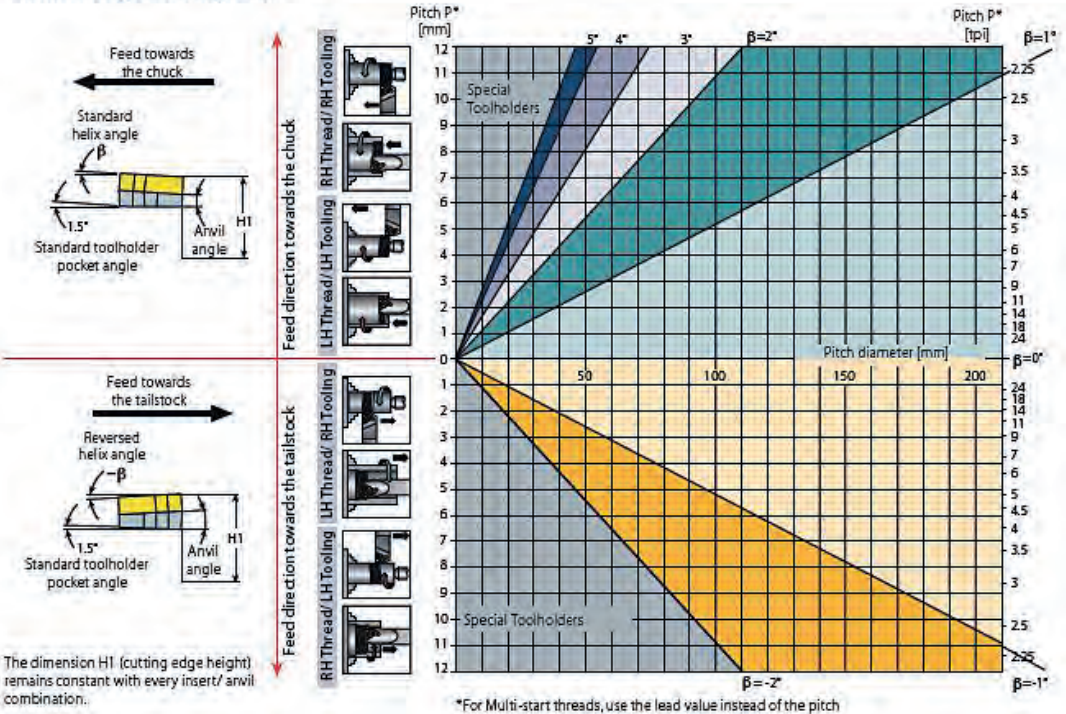

resultant pitch angle		4,5°	3,5°	2,5°	1,5°	0,5°	0°	-0,5°	-1,5°
Insert size 16 mm	shim angle	3°P	2°P	1°P	0°	1°N	1,5°N	2°N	3°N
	article number R	002.00.186	002.00.181	002.00.182	002.00.180	002.00.183	002.00.187	002.00.184	002.00.185
	article number L	002.00.196	002.00.191	002.00.192	002.00.190	002.00.193	002.00.197	002.00.194	002.00.195

Notizen / Notes / Notes

Lined area for notes with horizontal lines.

Notizen / Notes / Notes

Notizen / Notes / Notes

www.graf-werkzeugsysteme.de

Ernst **Graf** GmbH

Rosenstraße 1

D – 78661 Böhringen

 +49 7404 9305-0

 info@graf-werkzeugsysteme.de