



Boring



Reaming



Burnishing



Threading



Drilling

- ▶ BT-A Drill
- BTA-STS (Single Tube System) Machining



Specials



The Foundation

Since 1941, Allied Machine & Engineering has provided dependable and practical holemaking solutions to the world. What was once a small job shop in Ohio is now a worldwide leader in cutting tool technology. With three manufacturing facilities in Ohio, one in Georgia, another in Germany, and headquarters in both the United States and Europe, Allied Machine is positioned to bring innovative solutions and technical expertise directly to the customers' hands.



The Beginning



Harold E. Stokey founded Allied Machine & Engineering to aid the war effort, manufacturing taper bearing lock nuts for the production of M1 tanks. Years later, after a sales meeting gone wrong, Stokey possessed a warehouse stocked with spade drill inserts. He set forth into the industry that would become Allied Machine's thriving identity: holemaking.

The T-A[®]

When Harold's son, William H. Stokey, became the president and CEO, he developed the Throw Away—or T-A—spade drill insert system. The T-A revolutionized the holemaking industry, launching Allied Machine ahead of the competition. Since then, numerous innovations and advancements have been created from the T-A's inspiration.



The Innovation

Since the development of the T-A, Allied Machine has expanded its product offering to support a vast range of customer applications, including large diameter and deep hole drilling, boring, reaming, burnishing, porting, and threading.



The Future

Allied Machine is constantly investing in the brightest and sharpest minds, shaping a future filled with success and quality for customers around the world.



Steve Stokey
Executive Vice President

William H. Stokey
President and CEO

Mike Stokey
Executive Vice President



**ALLIED MACHINE
& ENGINEERING**

Holemaking Solutions for Today's Manufacturing

WOHLHAUPTER



SUPERION

CRITERION

DRILLING

High Penetration



GEN3SYS® XT Pro



GEN3SYS® XT



ASC 320®

General Production

(certain sizes are ideal for deep hole drilling and/or large diameter drilling)



GEN2 T-A®



Original T-A®



High Performance



Universal

Large Diameter



Revolution Drill®



Opening Drill®

Large Diameter / Deep Hole



APX Drill



BT-A Drill

Deep Hole



Guided T-A® Drill
(special)

Porting



AccuPort 432®

Structural Steel



GEN3SYS® XT



T-A®

BORING



WOHLHAUPTER®

Bringing you the finest in precision cutting tools

CRITERION™

REAMING



ALVAN®
Reaming Systems

S.C.A.M.I.®

BURNISHING



S.C.A.M.I.®
Roller Burnishing

THREADING



AccuThread™ 856
Pin Style Indexable



AccuThread™ 856
Bolt-in Style Indexable



AccuThread™ 856
Solid Carbide



ThreadMills USA
Solid Carbide



SPECIALS



Insta-Quote™
Online custom tool builder and quote generator



i-Form
Custom indexable drill / form tool system

Engineered Specials

If your special holmaking needs cannot be met with the Insta-Quote system, Allied Machine can specially engineer ANY product to make your application a success. Simply contact your local Field Sales Engineer or the Allied Machine Application Engineering department for assistance with creating your special tooling. Let Allied Machine resolve your challenges today.

Allied Machine & Engineering patent information can be found at www.alliedmachine.com/patents

BT-A Drill

BTA (STS) Deep Hole Machining System

▶ **Diameter Range:** 0.5100" - 1.8820" (12.95mm - 47.80mm)



Material Ejection with Efficiency

The BT-A Drill (using the single tube system, or STS) conquers deep hole applications in ways other drills simply cannot. The internal ejection system flushes chips and debris from the hole with no interference to the cutting process.

By utilizing the countless advantages of the T-A[®] drill insert, the BT-A design significantly increases penetration rates over brazed heads and traditional gun drills. A specific BT geometry has also been developed to increase productivity in these types of drilling applications.

Excellent hole size and finish	Optimizes chip evacuation	Up to 2x the penetration rate of traditional BTA heads
--------------------------------	---------------------------	---

Applicable Industries



Aerospace



Agriculture



Automotive



Heavy Equipment



Hydraulics



Tool, Mold, and Die



Oil & Gas

Your safety and the safety of others is very important. This catalog contains important safety messages. Always read and follow all safety precautions.



This triangle is a safety hazard symbol. It alerts you to potential safety hazards that can cause tool failure and serious injury.

When you see this symbol in the catalog, look for a related safety message that may be near this triangle or referred to in the nearby text.

There are safety signal words also used in the catalog. Safety messages follow these words.

WARNING

WARNING (shown above) means that failure to follow the precautions in this message could result in tool failure and serious injury.

NOTICE means that failure to follow the precautions in this message could result in damage to the tool or machine but not result in personal injury.

NOTE and **IMPORTANT** are also used. These are important that you read and follow but are not safety-related.

Visit www.alliedmachine.com for the most up-to-date information and procedures.

Reference Icons

The following icons will appear throughout the catalog to help you navigate between products.

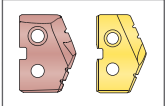

T-A® Inserts

Refers to the range of inserts that connect with the corresponding holders

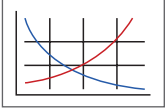

Recommended Cutting Data

Speed and feed recommendations for optimum and safe drilling

Introduction Information

System Overview 2
 Product Nomenclature 3

T-A Drill Series

0 Series 4
 1 Series 5
 2 Series 6
 3 Series 7

Series	Diameter Range	
	Imperial (inch)	Metric (mm)
0	0.5100 - 0.6959	12.95 - 17.68
1	0.6960 - 0.9600	17.69 - 24.38
2	0.9601 - 1.3800	24.39 - 35.05
3	1.3801 - 1.8820	35.06 - 47.80

System Overview

BTA Machining

BTA machining is the reverse of typical gun drilling systems. The BT-A Drill is a drill head consisting of a holder body and a replaceable tip T-A® insert. The drill head threads into an STS (single tube system) cylindrical tube with a diameter smaller than the drill head. The difference in diameter forms an annular area between the hole and the tube OD. This allows high volume coolant to be directed to the cutting edge.

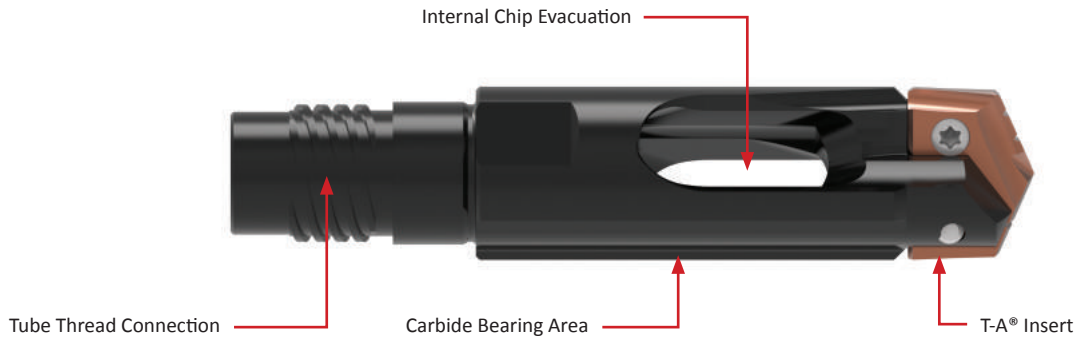

- ✓ **Improve hole straightness**
with the laser clad bearing area
- ✓ **Eliminate the need for re-sharpening**
with replaceable cutting edges
- ✓ **Reduce your inventory**
with the replaceable T-A® feature
- ✓ **Compatibility**
heads are compatible with standard BTA-STS systems
- ✓ **Balanced cutting forces**
- ✓ **Patent-pending design**

Original T-A Insert: BT-A Geometry (-BT)

- Low thrust web geometry reduces Z-axis requirements
- Tiny chip (-TC) lip geometry improves chip formation
- Polished cutting surface eliminates material build-up

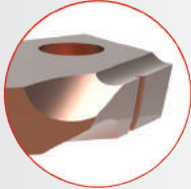

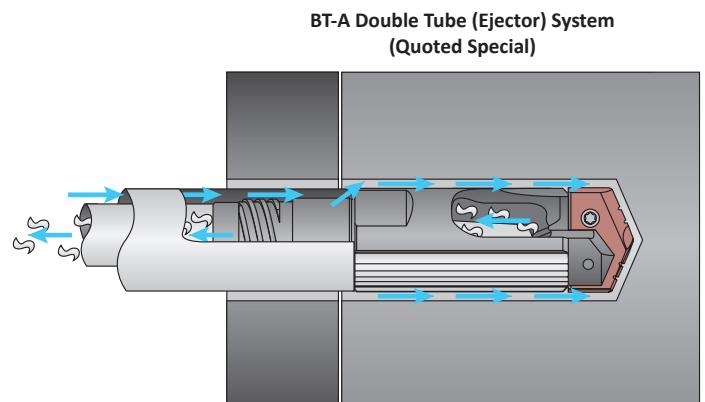
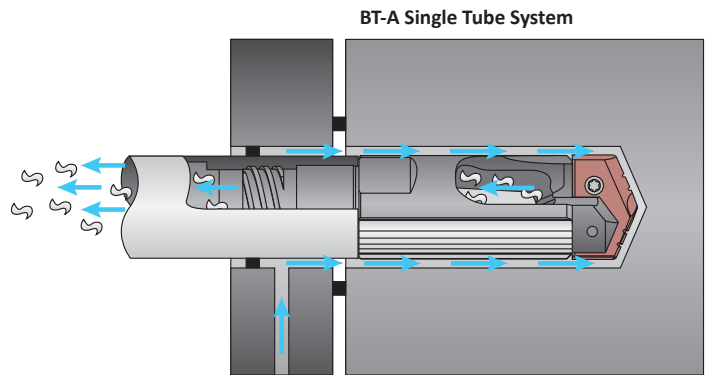

2x INCREASE in penetration rates over traditional BTA heads

Product Nomenclature

BT-A Drill Holders

BTA2	-	804	-	1.1299
1		2		3

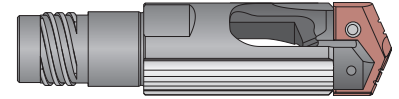

1. BT-A Drill T-A Insert Series
BTA0 = 0 series T-A insert
BTA1 = 1 series T-A insert
BTA2 = 2 series T-A insert
BTA3 = 3 series T-A insert

2. Tube Size
794 800 806
795 801 807
796 802 808
797 803 809
798 804 810
799 805 811

3. Diameter
0.7344 = Inch
25.00 = Metric

Reference Key

Symbol	Attribute
D_1	Drill insert range
L_1	Overall length
L_3	Holder reference length
L_7	Shank length

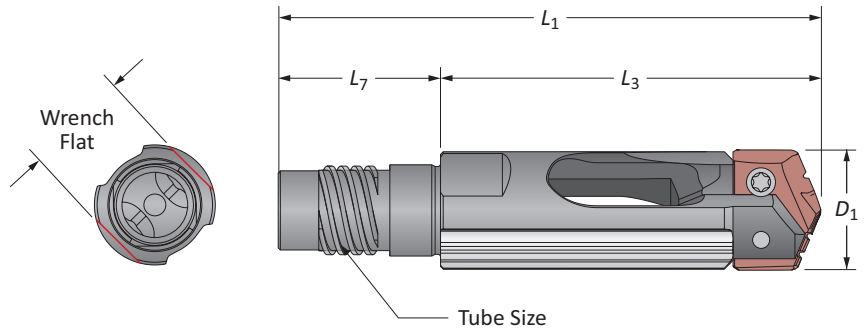

BT-A Drill Tubes

BTAT	-	804	-	63
1		2		3

1. BT-A Drill T-A Insert Series
BTAT = BT-A Tube

2. Tube Size
794 800 806
795 801 807
796 802 808
797 803 809
798 804 810
799 805 811

3. Length
63 = Standard
102 = Long

Reference Key

Symbol	Attribute
D_1	Body diameter
ID_1	Internal diameter
OD_1	Outer diameter
L_1	Overall length

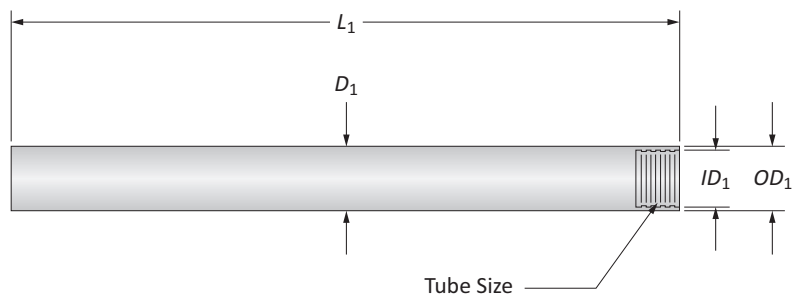



BT-A Drill Holders

0 Series | Diameter Range: 0.5100" - 0.6959" (12.95mm - 17.68mm)

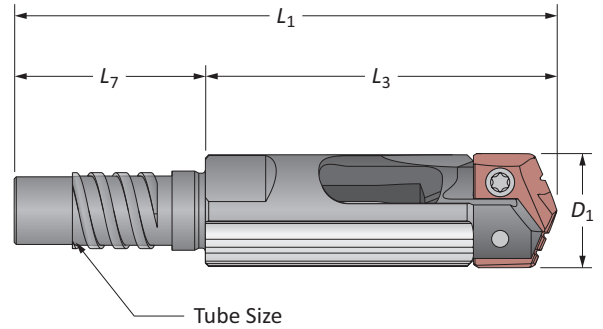
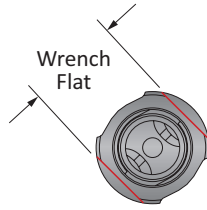
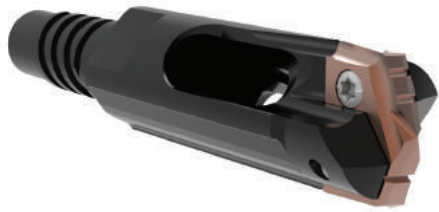

Tube Size	D_1	Holder				Part No.	T-A® Insert	Wrench Flat (mm)
		L_3	L_1	L_7				
i	794	0.5100 - 0.5359	1-45/64	2-39/64	29/32	BTA0-794-X.XXXX	1C10H-XXXX-BT	11
	795	0.5360 - 0.5759	1-3/4	2-21/32	29/32	BTA0-795-X.XXXX	1C10H-XXXX-BT	12
	796	0.5760 - 0.6149	1-13/16	2-3/4	61/64	BTA0-796-X.XXXX	1C10H-XXXX-BT	13
	797	0.6150 - 0.6579	1-13/16	2-3/4	61/64	BTA0-797-X.XXXX	1C10H-XXXX-BT	14
	798	0.6580 - 0.6959	1-25/32	2-47/64	61/64	BTA0-798-X.XXXX	1C10H-XXXX-BT	15
m	794	12.95 - 13.61	43.4	66.4	23	BTA0-794-X.XXXX	1C10H-XXXX-BT	11
	795	13.62 - 14.63	44.6	67.6	23	BTA0-795-X.XXXX	1C10H-XXXX-BT	12
	796	14.64 - 15.62	45.9	69.9	24	BTA0-796-X.XXXX	1C10H-XXXX-BT	13
	797	15.63 - 16.71	45.9	69.9	24	BTA0-797-X.XXXX	1C10H-XXXX-BT	14
	798	16.72 - 17.68	45.3	69.3	24	BTA0-798-X.XXXX	1C10H-XXXX-BT	15

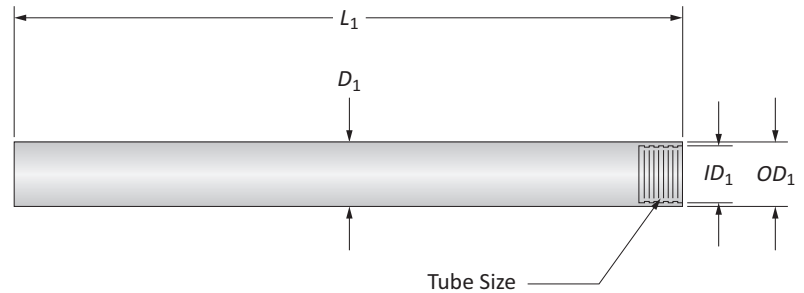

Tube Size	D_1 Range	Tube			L_1	Part No.
		OD_1	ID_1			
i	794	0.510 - 0.535	0.433	0.276	63	BTAT794-63
	794	0.510 - 0.535	0.433	0.276	102	BTAT794-102
	795	0.536 - 0.575	0.472	0.315	63	BTAT795-63
	795	0.536 - 0.575	0.472	0.315	102	BTAT795-102
	796	0.576 - 0.614	0.512	0.335	63	BTAT796-63
	796	0.576 - 0.614	0.512	0.335	102	BTAT796-102
	797	0.615 - 0.657	0.551	0.354	63	BTAT797-63
	797	0.615 - 0.657	0.551	0.354	102	BTAT797-102
	798	0.658 - 0.696	0.591	0.394	63	BTAT798-63
	798	0.658 - 0.696	0.591	0.394	102	BTAT798-102

Section A30

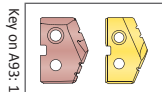

i = Imperial (in)
m = Metric (mm)

BT-A Drill Holders

1 Series | Diameter Range: 0.6960" - 0.9600" (17.69mm - 24.38mm)

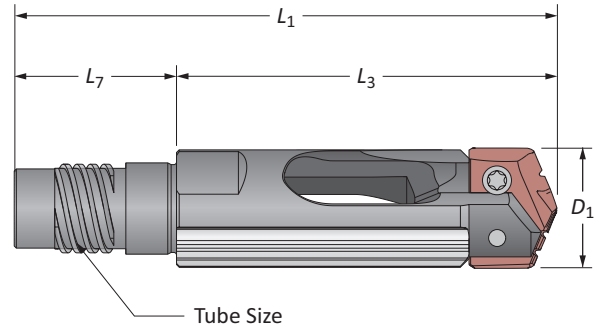
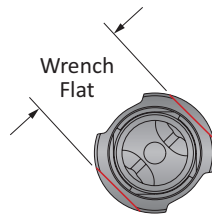

Tube Size	D_1	Holder			Part No.	T-A® Insert	Wrench Flat (mm)	
		L_3	L_1	L_7				
i	799	0.6960 - 0.7449	2-15/64	3-9/32	63/64	BTA1-799-X.XXXX	1C11H-XXXX-BT	16
	800	0.7450 - 0.7879	2-5/16	3-27/64	1-7/64	BTA1-800-X.XXXX	1C11H-XXXX-BT	17
	801	0.7880 - 0.8589	2-11/32	3-35/64	1-13/64	BTA1-801-X.XXXX	1C11H-XXXX-BT	18
	802	0.8590 - 0.9489	2-25/64	3-11/16	1-19/64	BTA1-802-X.XXXX	1C11H-XXXX-BT	19
	803	0.9490 - 0.9600	2-33/64	3-13/16	1-19/64	BTA1-803-X.XXXX	1C11H-XXXX-BT	21
m	799	17.69 - 18.92	58.2	83.2	25	BTA1-799-X.XXXX	1C11H-XXXX-BT	16
	800	18.93 - 20.01	58.8	86.8	28	BTA1-800-X.XXXX	1C11H-XXXX-BT	17
	801	20.02 - 21.81	59.4	89.9	30.5	BTA1-801-X.XXXX	1C11H-XXXX-BT	18
	802	21.82 - 24.10	60.7	93.7	33	BTA1-802-X.XXXX	1C11H-XXXX-BT	19
	803	24.11 - 24.38	63.9	96.9	33	BTA1-803-X.XXXX	1C11H-XXXX-BT	21

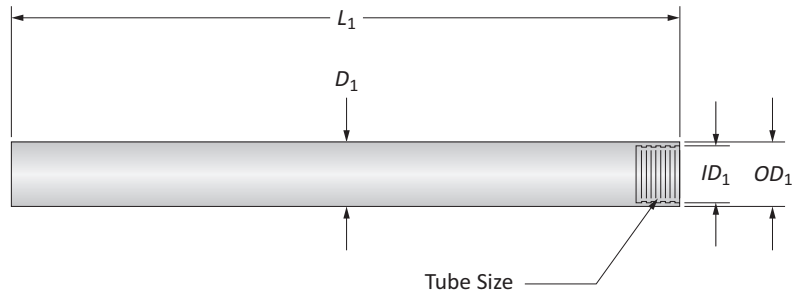

Tube Size	D_1 Range	Tube			Part No.	
		OD_1	ID_1	L_1		
i	799	17.69 - 18.90	16.0	10.5	1600	BTAT799-63
	799	17.69 - 18.90	16.0	10.5	2591	BTAT799-102
	800	18.91 - 20.00	17.0	11.5	1600	BTAT800-63
	800	18.91 - 20.00	17.0	11.5	2591	BTAT800-102
	801	20.01 - 21.79	18.0	12.0	1600	BTAT801-63
	801	20.01 - 21.79	18.0	12.0	2591	BTAT801-102
	802	21.80 - 24.08	20.0	13.0	1600	BTAT802-63
	802	21.80 - 24.08	20.0	13.0	2591	BTAT802-102
	803	24.09 - 26.39	22.0	14.0	1600	BTAT803-63
	803	24.09 - 26.39	22.0	14.0	2591	BTAT803-102

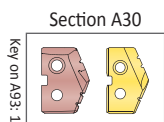



i = Imperial (in)
m = Metric (mm)

A DRILLING
B BORING
C REAMING
D BURNISHING
E THREADING
X SPECIALS

BT-A Drill Holders

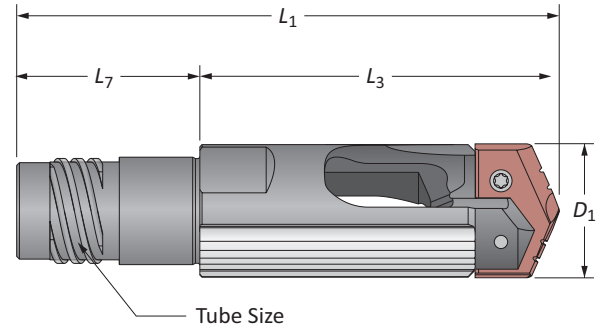
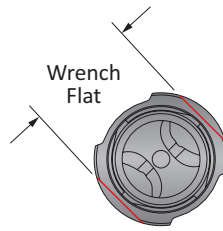
2 Series | Diameter Range: 0.9601" - 1.3800" (24.39mm - 35.05mm)



Tube Size	D_1	Holder				Part No.	 T-A® Insert	Wrench Flat (mm)
		L_3	L_1	L_7				
i	803	0.9601 - 1.0399	3-3/32	4-25/64	1-19/64	BTA2-803-X.XXXX	1C12H-XXXX-BT	21
	804	1.0400 - 1.1299	3	4-3/32	1-7/64	BTA2-804-X.XXXX	1C12H-XXXX-BT	22
	805	1.1300 - 1.2209	2-31/32	4-25/64	1-27/64	BTA2-805-X.XXXX	1C12H-XXXX-BT	25
	806	1.2210 - 1.3119	3-1/16	4-31/64	1-27/64	BTA2-806-X.XXXX	1C12H-XXXX-BT	27
	807	1.3120 - 1.3800	3-1/16	4-31/64	1-27/64	BTA2-807-X.XXXX	1C12H-XXXX-BT	30
m	803	24.39 - 26.41	78.5	111.5	33	BTA2-803-X.XXXX	1C12H-XXXX-BT	21
	804	26.42 - 28.70	75.9	103.9	28	BTA2-804-X.XXXX	1C12H-XXXX-BT	22
	805	28.71 - 31.01	75.4	111.4	36	BTA2-805-X.XXXX	1C12H-XXXX-BT	25
	806	31.02 - 33.32	77.9	113.8	36	BTA2-806-X.XXXX	1C12H-XXXX-BT	27
	807	33.33 - 35.05	77.9	113.8	36	BTA2-807-X.XXXX	1C12H-XXXX-BT	30

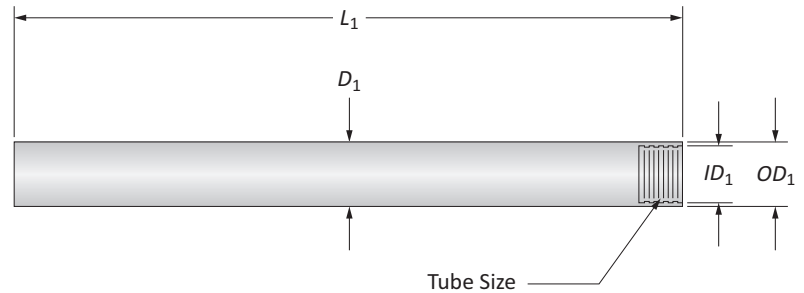

Tube Size	D_1 Range	Tube			L_1	Part No.
		OD_1	ID_1			
i	803	0.949 - 1.039	0.866	0.551	63	BTAT803-63
	803	0.949 - 1.039	0.866	0.551	102	BTAT803-102
	804	1.040 - 1.129	0.945	0.610	63	BTAT804-63
	804	1.040 - 1.129	0.945	0.610	102	BTAT804-102
	805	1.130 - 1.220	1.024	0.669	63	BTAT805-63
	805	1.130 - 1.220	1.024	0.669	102	BTAT805-102
	806	1.221 - 1.311	1.102	0.728	102	BTAT806-102
	807	1.312 - 1.425	1.181	0.787	102	BTAT807-102

Section A30

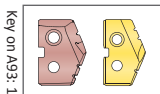

i = Imperial (in)
m = Metric (mm)

BT-A Drill Holders

3 Series | Diameter Range: 1.3801" - 1.8820" (35.06mm - 47.80mm)

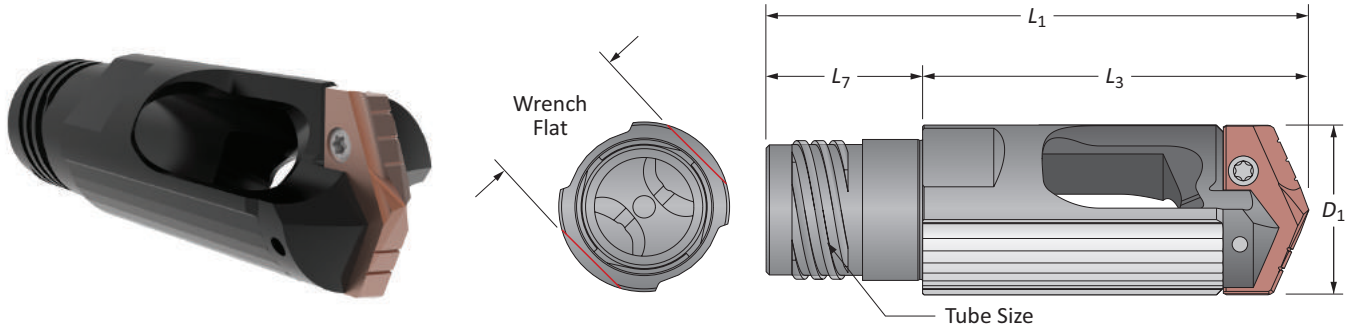

	Tube Size	D_1	Holder			Part No.	Wrench Flat (mm)
			L_3	L_1	L_7		
i	807	1.3801 - 1.4259	3-13/16	5-15/64	1-27/64	BTA3-807-X.XXXX	30
	808	1.4260 - 1.5599	3-15/16	5-11/16	1-3/4	BTA3-808-X.XXXX	32
	809	1.5600 - 1.6929	4-1/16	5-3/4	1-11/16	BTA3-809-X.XXXX	36
	810	1.6930 - 1.8509	4-1/64	5-45/64	1-11/16	BTA3-810-X.XXXX	41
	811	1.8510 - 1.8820	4-1/16	5-3/4	1-11/16	BTA3-811-X.XXXX	41
m	807	35.06 - 36.22	96.8	132.8	36	BTA3-807-X.XXXX	30
	808	36.23 - 39.62	100.0	144.4	44.5	BTA3-808-X.XXXX	32
	809	39.63 - 43.00	103.1	146.2	43	BTA3-809-X.XXXX	36
	810	43.01 - 47.01	101.9	144.9	43	BTA3-810-X.XXXX	41
	811	47.02 - 47.80	103.2	146.2	43	BTA3-811-X.XXXX	41

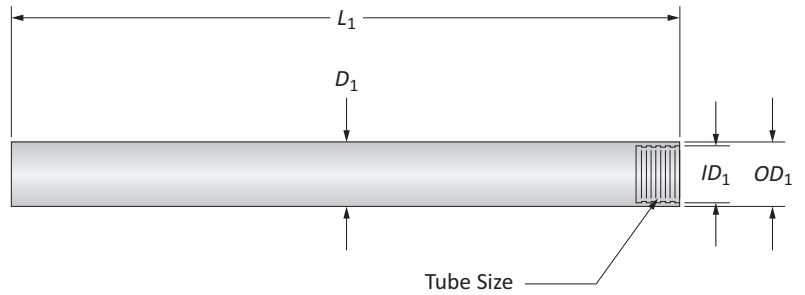

	Tube Size	D_1 Range	Tube			Part No.
			OD_1	ID_1	L_1	
i	807	1.312 - 1.425	1.181	0.787	102	BTAT807-102
	808	1.426 - 1.559	1.299	0.906	102	BTAT808-102
	809	1.560 - 1.692	1.417	0.984	102	BTAT809-102
	810	1.693 - 1.850	1.535	1.102	102	BTAT810-102
	811	1.851 - 1.882	1.693	1.220	102	BTAT811-102

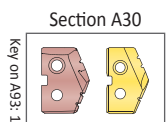

i = Imperial (in)
m = Metric (mm)

Warranty Information

Allied Machine & Engineering warrants to original equipment manufacturers, distributors, industrial and commercial users of its products that each new product manufactured or supplied by Allied Machine shall be free from defects in material and workmanship.

Allied Machine's obligation under this warranty is limited to furnishing without additional charge a replacement or, at its option repairing or issuing credit for any product which shall within one year from the date of sale be returned freight prepaid to the plant designated by an Allied Machine representative and which upon inspection is determined by Allied Machine to be defective in materials or workmanship.

Complete information as to operating conditions, machine, set-up, and application of cutting fluid should accompany any product returned for inspection. The provisions of this warranty shall not apply to any Allied Machine products which have been subjected to misuse, improper operating conditions, machine set-up or application of cutting fluid or which have been repaired or altered if such repair or alteration in the judgment of Allied Machine would adversely affect performance of the product.

THIS WARRANTY IS IN LIEU OF ALL OTHER WARRANTIES, EXPRESS OR IMPLIED, INCLUDING ANY IMPLIED WARRANTY OF MERCHANTABILITY OR FITNESS FOR A PARTICULAR PURPOSE. Allied Machine shall have no liability or responsibility on any claim of any kind, whether in contract, tort or otherwise, for any loss or damage arising out of, connected with, or resulting from the manufacture, sale, delivery or use of any product sold hereunder, in excess of the cost of replacement or repair as provided herein.

ALL PRICES, DELIVERIES, DESIGNS, AND MATERIALS ARE SUBJECT TO CHANGE WITHOUT NOTICE.



Allied Machine & Engineering
Registered to ISO 9001
10001329

United States

Allied Machine & Engineering

120 Deeds Drive
Dover OH 44622
United States

Phone:
330.343.4283

Fax:
330.602.3400

Toll Free USA and Canada:
800.321.5537

Toll Free USA and Canada:
800.223.5140

Allied Machine & Engineering

485 W Third Street
Dover OH 44622
United States

Phone:
330.343.4283

Fax:
330.364.7666
(Engineering Dept.)

Toll Free USA and Canada:
800.321.5537

Europe

Allied Machine & Engineering Co. (Europe) Ltd.

93 Vantage Point
Pensnett Estate
Kingswinford
West Midlands
DY6 7FR England

Phone:
+44 (0) 1384 400900

Fax:
+44 (0) 1384 400105

Wohlhaupter GmbH

Maybachstrasse 4
Postfach 1264
72636 Frickenhausen
Germany

Phone:
011-49-7022-408-0

Fax:
011-49-7022-408-212

Asia

Wohlhaupter India Pvt. Ltd.

B-23, 2nd Floor
B Block Community Centre
Janakpuri, New Delhi - 110058
India

Phone:
+91-11-41827044

Your local Allied Machine representative:



Febametal S.p.A.
Via Grandi 15, 10095
Grugliasco (TO)
www.febametal.com
011-7701412
febametal@febametal.com

www.alliedmachine.com

Allied Machine & Engineering is registered by DQS to ISO 9001 10001329



© 2017 Allied Machine & Engineering
Available Online Only: A93-BTA
Publish Date: June 2017