

**Inserti per tornitura**

C

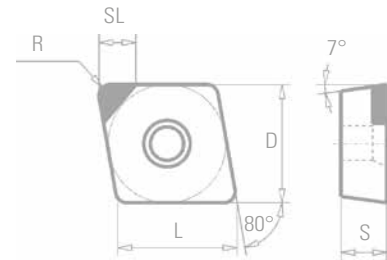

Codice ISO	Quota SL	HS 61	HS 33	HS 62	CI 02
CCGW 060202	3,00	<input type="checkbox"/>	<input checked="" type="checkbox"/>	<input type="checkbox"/>	<input checked="" type="checkbox"/>
CCGW 060204	3,00	<input type="checkbox"/>	<input checked="" type="checkbox"/>	<input type="checkbox"/>	<input checked="" type="checkbox"/>
CCGW 060208	3,00	<input type="checkbox"/>	<input type="checkbox"/>	<input type="checkbox"/>	<input type="checkbox"/>
CCGW 080304	3,00	<input type="checkbox"/>	<input type="checkbox"/>	<input type="checkbox"/>	<input type="checkbox"/>
CCGW 080308	3,00	<input type="checkbox"/>	<input type="checkbox"/>	<input type="checkbox"/>	<input type="checkbox"/>
CCGW 090304	4,00	<input type="checkbox"/>	<input type="checkbox"/>	<input type="checkbox"/>	<input type="checkbox"/>
CCGW 090308	4,00	<input type="checkbox"/>	<input type="checkbox"/>	<input type="checkbox"/>	<input type="checkbox"/>
CCGW 09T302	4,00	<input type="checkbox"/>	<input type="checkbox"/>	<input type="checkbox"/>	<input type="checkbox"/>
CCGW 09T304	4,00	<input type="checkbox"/>	<input checked="" type="checkbox"/>	<input type="checkbox"/>	<input checked="" type="checkbox"/>
CCGW 09T308	4,00	<input type="checkbox"/>	<input checked="" type="checkbox"/>	<input type="checkbox"/>	<input checked="" type="checkbox"/>
CCGW 120402	4,00	<input type="checkbox"/>	<input type="checkbox"/>	<input type="checkbox"/>	<input type="checkbox"/>
CCGW 120404	4,00	<input type="checkbox"/>	<input checked="" type="checkbox"/>	<input type="checkbox"/>	<input checked="" type="checkbox"/>
CCGW 120408	4,00	<input type="checkbox"/>	<input checked="" type="checkbox"/>	<input type="checkbox"/>	<input checked="" type="checkbox"/>
CCGW 120412	4,00	<input type="checkbox"/>	<input type="checkbox"/>	<input type="checkbox"/>	<input type="checkbox"/>



Geometria Wiper destra e sinistra	Quota SL	HS 61	HS 33	HS 62	CI 02
W-CCGW 09T302	4,00	<input type="checkbox"/>	<input type="checkbox"/>	<input type="checkbox"/>	<input type="checkbox"/>
W-CCGW 09T304	4,00	<input type="checkbox"/>	<input type="checkbox"/>	<input type="checkbox"/>	<input type="checkbox"/>
W-CCGW 09T308	4,00	<input type="checkbox"/>	<input type="checkbox"/>	<input type="checkbox"/>	<input type="checkbox"/>



Esecuzione destra

L-CCGW 060202 R	6,40	<input type="checkbox"/>	<input type="checkbox"/>	<input type="checkbox"/>	<input type="checkbox"/>
L-CCGW 060204 R	6,40	<input type="checkbox"/>	<input type="checkbox"/>	<input type="checkbox"/>	<input type="checkbox"/>
L-CCGW 09T302 R	9,70	<input type="checkbox"/>	<input type="checkbox"/>	<input type="checkbox"/>	<input type="checkbox"/>
L-CCGW 09T304 R	9,70	<input type="checkbox"/>	<input type="checkbox"/>	<input type="checkbox"/>	<input type="checkbox"/>
L-CCGW 09T308 R	9,70	<input type="checkbox"/>	<input type="checkbox"/>	<input type="checkbox"/>	<input type="checkbox"/>
L-CCGW 120404 R	12,90	<input type="checkbox"/>	<input type="checkbox"/>	<input type="checkbox"/>	<input type="checkbox"/>
L-CCGW 120408 R	12,90	<input type="checkbox"/>	<input type="checkbox"/>	<input type="checkbox"/>	<input type="checkbox"/>

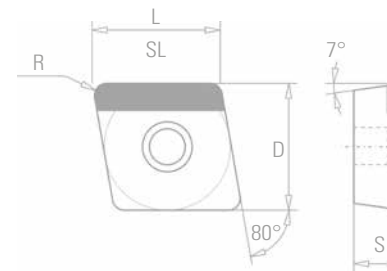

Esecuzione sinistra

L-CCGW 060202 L	6,40	<input type="checkbox"/>	<input type="checkbox"/>	<input type="checkbox"/>	<input type="checkbox"/>
L-CCGW 060204 L	6,40	<input type="checkbox"/>	<input type="checkbox"/>	<input type="checkbox"/>	<input type="checkbox"/>
L-CCGW 09T302 L	9,70	<input type="checkbox"/>	<input type="checkbox"/>	<input type="checkbox"/>	<input type="checkbox"/>
L-CCGW 09T304 L	9,70	<input type="checkbox"/>	<input type="checkbox"/>	<input type="checkbox"/>	<input type="checkbox"/>
L-CCGW 09T308 L	9,70	<input type="checkbox"/>	<input type="checkbox"/>	<input type="checkbox"/>	<input type="checkbox"/>
L-CCGW 120404 L	12,90	<input type="checkbox"/>	<input type="checkbox"/>	<input type="checkbox"/>	<input type="checkbox"/>
L-CCGW 120408 L	12,90	<input type="checkbox"/>	<input type="checkbox"/>	<input type="checkbox"/>	<input type="checkbox"/>

Esempio d'ordine: CCGW 120404 HS33

**N.B. Prezzo cad. per 5 pz. e più. Ordinativo minimo 3 pz. Per 3 e 4 pezzi considerare maggiorazione +10%**

Vedi la descrizione delle leghe a pagina 6

■ -disponibile a stock

□ -disponibile in breve tempo su richiesta

**Inserti per tornitura**

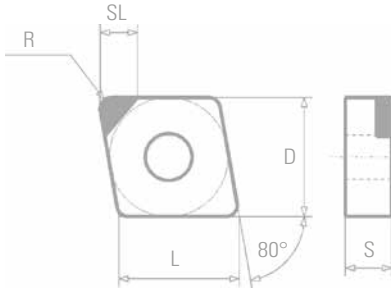

Codice ISO	Quota SL	HS 61	HS 33	HS 62	CI 02
CNGA 120401	4,00	☐	■	☐	☐
CNGA 120402	4,00	☐	■	☐	■
CNGA 120403	4,00	☐	☐	☐	☐
CNGA 120404	4,00	☐	■	☐	■
CNGA 120406	4,00	☐	☐	☐	☐
CNGA 120408	4,00	☐	■	☐	■
CNGA 120410	4,00	☐	■	☐	☐
CNGA 120412	4,00	☐	■	☐	■
CNGA 120416	4,00	☐	☐	☐	☐

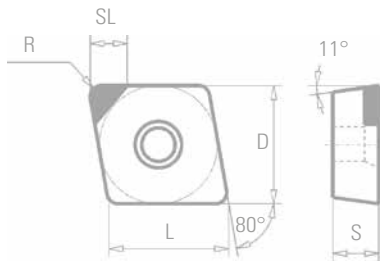

CPGW 05T102	3,00	☐	☐	☐	☐
CPGW 05T104	3,00	☐	■	☐	☐
CPGW 060202	3,00	☐	■	☐	■
CPGW 060204	3,00	☐	■	☐	■
CPGW 090304	4,00	☐	☐	☐	☐
CPGW 090308	4,00	☐	☐	☐	☐
CPGW 09T304	4,00	☐	■	☐	■
CPGW 09T308	4,00	☐	■	☐	■
CPGW 120404	4,00	☐	☐	☐	☐
CPGW 120408	4,00	☐	☐	☐	☐

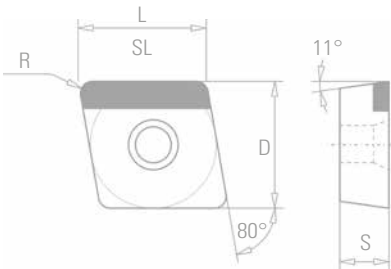

L CPGW 060202 R	6,40	☐	☐	☐	☐
L CPGW 060204 R	6,40	☐	■	☐	☐
L CPGW 09T302 R	9,70	☐	☐	☐	☐
L CPGW 09T304 R	9,70	☐	☐	☐	☐
L CPGW 120404 R	12,90	☐	☐	☐	☐
L CPGW 120408 R	12,90	☐	☐	☐	☐



Esecuzione destra

L CPGW 060202 L	6,40	☐	☐	☐	☐
L CPGW 060204 L	6,40	☐	■	☐	☐
L CPGW 09T302 L	9,70	☐	☐	☐	☐
L CPGW 09T304 L	9,70	☐	☐	☐	☐
L CPGW 120404 L	12,90	☐	☐	☐	☐
L CPGW 120408 L	12,90	☐	☐	☐	☐



Esecuzione sinistra

Esempio d'ordine: CCGW 120404 HS33

**N.B. Prezzo cad. per 5 pz. e più. Ordinativo minimo 3 pz. Per 3 e 4 pezzi considerare maggiorazione +10%**

Vedi la descrizione delle leghe a pagina 6

- -disponibile a stock
- ☐ -disponibile in breve tempo su richiesta

**Inserti per tornitura**

**D**



Codice ISO	Quota SL	HS 61	HS 33	HS 62	CI 02
DCGW 070202	3,00	☐	■	☐	■
DCGW 070204	3,00	☐	■	☐	■
DCGW 070208	3,00	☐	■	☐	■
DCGW 11T302	4,00	☐	■	☐	■
DCGW 11T304	4,00	☐	■	☐	■
DCGW 11T308	4,00	☐	■	☐	■
DCGW 150404	4,00	☐	☐	☐	☐
DCGW 150408	4,00	☐	☐	☐	☐



DNGA 150404	4,00	☐	■	☐	☐
DNGA 150408	4,00	☐	■	☐	☐
DNGA 150412	4,00	☐	■	☐	■
DNGA 150604	4,00	☐	■	☐	■
DNGA 150608	4,00	☐	■	☐	■
DNGA 150612	4,00	☐	☐	☐	☐



DPGW 070202	3,00	☐	☐	☐	☐
DPGW 070204	3,00	☐	☐	☐	☐
DPGW 070208	3,00	☐	☐	☐	☐
DPGW 11T302	4,00	☐	☐	☐	☐
DPGW 11T304	4,00	☐	☐	☐	■
DPGW 11T308	4,00	☐	■	☐	☐

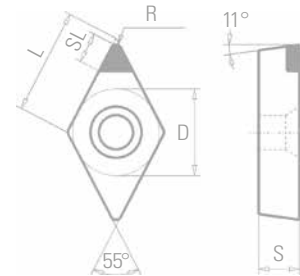
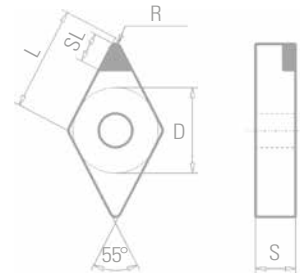
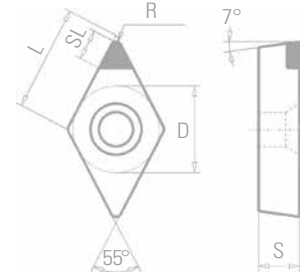

**E**



Codice ISO	Quota SL	HS 61	HS 33	HS 62	CI 02
ECGW 09T304	4,00	☐	☐	☐	☐
ECGW 09T308	4,00	☐	☐	☐	☐
ECGW 12T304	4,00	☐	☐	☐	☐
ECGW 12T308	4,00	☐	☐	☐	■

EPGW 040202	2,60	☐	☐	☐	☐
EPGW 040204	2,60	☐	☐	☐	☐
EPGW 060202	3,00	☐	☐	☐	☐
EPGW 060204	3,00	☐	☐	☐	☐
EPGW 080302	4,00	☐	☐	☐	☐
EPGW 080304	4,00	☐	☐	☐	☐
EPGW 080308	4,00	☐	☐	☐	☐

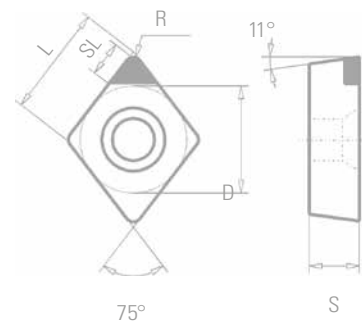
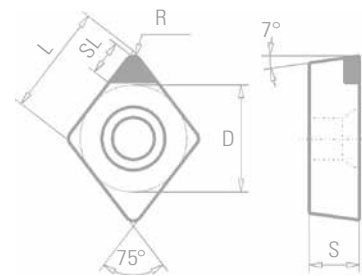

Esempio d'ordine: CCGW 120404 HS33

N.B. Prezzo cad. per 5 pz. e più. Ordinativo minimo 3 pz. Per 3 e 4 pezzi considerare maggiorazione +10%

Vedi la descrizione delle leghe a pagina 6

■ -disponibile a stock

☐ -disponibile in breve tempo su richiesta

**Inserti per tornitura**

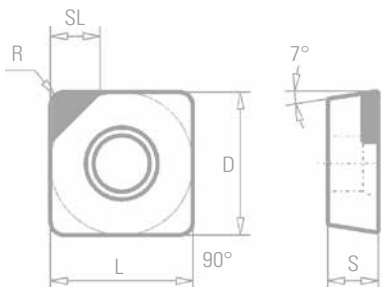

Codice ISO	Quota SL	HS 61	HS 33	HS 62	CI 02
SCGW 060202	3,00	<input type="checkbox"/>	<input type="checkbox"/>	<input type="checkbox"/>	<input type="checkbox"/>
SCGW 060204	3,00	<input type="checkbox"/>	<input type="checkbox"/>	<input type="checkbox"/>	<input type="checkbox"/>
SCGW 090302	4,00	<input type="checkbox"/>	<input type="checkbox"/>	<input type="checkbox"/>	<input type="checkbox"/>
SCGW 090304	4,00	<input type="checkbox"/>	<input type="checkbox"/>	<input type="checkbox"/>	<input type="checkbox"/>
SCGW 090308	4,00	<input type="checkbox"/>	<input type="checkbox"/>	<input type="checkbox"/>	<input type="checkbox"/>
SCGW 09T302	4,00	<input type="checkbox"/>	<input checked="" type="checkbox"/>	<input type="checkbox"/>	<input checked="" type="checkbox"/>
SCGW 09T304	4,00	<input type="checkbox"/>	<input checked="" type="checkbox"/>	<input type="checkbox"/>	<input checked="" type="checkbox"/>
SCGW 09T308	4,00	<input type="checkbox"/>	<input checked="" type="checkbox"/>	<input type="checkbox"/>	<input checked="" type="checkbox"/>
SCGW 120404	4,00	<input type="checkbox"/>	<input checked="" type="checkbox"/>	<input type="checkbox"/>	<input checked="" type="checkbox"/>
SCGW 120408	4,00	<input type="checkbox"/>	<input checked="" type="checkbox"/>	<input type="checkbox"/>	<input checked="" type="checkbox"/>

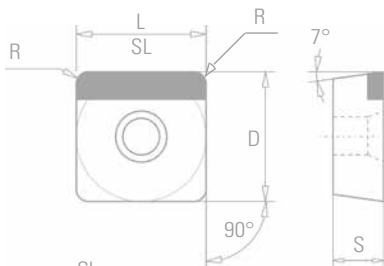

L SCGW 060202	6,35	<input type="checkbox"/>	<input type="checkbox"/>	<input type="checkbox"/>	<input type="checkbox"/>
L SCGW 060204	6,35	<input type="checkbox"/>	<input type="checkbox"/>	<input type="checkbox"/>	<input type="checkbox"/>
L SCGW 09T302	9,52	<input type="checkbox"/>	<input type="checkbox"/>	<input type="checkbox"/>	<input type="checkbox"/>
L SCGW 09T304	9,52	<input type="checkbox"/>	<input type="checkbox"/>	<input type="checkbox"/>	<input type="checkbox"/>
L SCGW 09T308	9,52	<input type="checkbox"/>	<input type="checkbox"/>	<input type="checkbox"/>	<input type="checkbox"/>
L SCGW 120404	12,70	<input type="checkbox"/>	<input type="checkbox"/>	<input type="checkbox"/>	<input type="checkbox"/>
L SCGW 120408	12,70	<input type="checkbox"/>	<input type="checkbox"/>	<input type="checkbox"/>	<input type="checkbox"/>

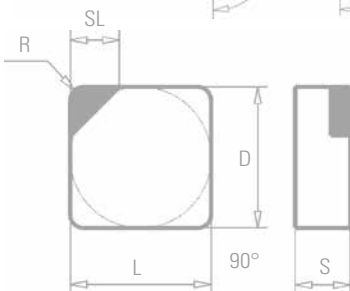

SNGN 090304	4,00	<input type="checkbox"/>	<input type="checkbox"/>	<input type="checkbox"/>	<input type="checkbox"/>
SNGN 090308	4,00	<input type="checkbox"/>	<input type="checkbox"/>	<input type="checkbox"/>	<input type="checkbox"/>
SNGN 120304	4,00	<input type="checkbox"/>	<input type="checkbox"/>	<input type="checkbox"/>	<input type="checkbox"/>
SNGN 120308	4,00	<input type="checkbox"/>	<input type="checkbox"/>	<input type="checkbox"/>	<input type="checkbox"/>
SNGN 120404	4,00	<input type="checkbox"/>	<input type="checkbox"/>	<input type="checkbox"/>	<input type="checkbox"/>
SNGN 120408	4,00	<input type="checkbox"/>	<input type="checkbox"/>	<input type="checkbox"/>	<input type="checkbox"/>

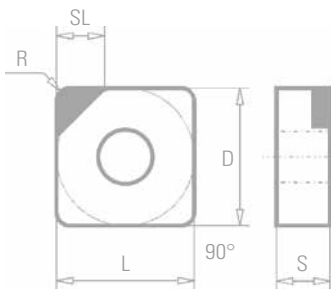

SNGA 090304	4,00	<input type="checkbox"/>	<input type="checkbox"/>	<input type="checkbox"/>	<input type="checkbox"/>
SNGA 090308	4,00	<input type="checkbox"/>	<input type="checkbox"/>	<input type="checkbox"/>	<input type="checkbox"/>
SNGA 120404	4,00	<input type="checkbox"/>	<input checked="" type="checkbox"/>	<input type="checkbox"/>	<input checked="" type="checkbox"/>
SNGA 120408	4,00	<input type="checkbox"/>	<input checked="" type="checkbox"/>	<input type="checkbox"/>	<input checked="" type="checkbox"/>

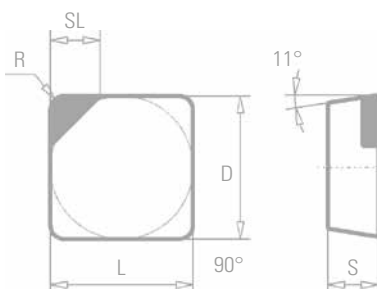

SPGN 070202	3,00	<input type="checkbox"/>	<input type="checkbox"/>	<input type="checkbox"/>	<input type="checkbox"/>
SPGN 070204	3,00	<input type="checkbox"/>	<input type="checkbox"/>	<input type="checkbox"/>	<input type="checkbox"/>
SPGN 090302	4,00	<input type="checkbox"/>	<input type="checkbox"/>	<input type="checkbox"/>	<input type="checkbox"/>
SPGN 090304	4,00	<input type="checkbox"/>	<input type="checkbox"/>	<input type="checkbox"/>	<input type="checkbox"/>
SPGN 120304	4,00	<input type="checkbox"/>	<input type="checkbox"/>	<input type="checkbox"/>	<input type="checkbox"/>
SPGN 120308	4,00	<input type="checkbox"/>	<input type="checkbox"/>	<input type="checkbox"/>	<input type="checkbox"/>
SPGN 120404	4,00	<input type="checkbox"/>	<input type="checkbox"/>	<input type="checkbox"/>	<input type="checkbox"/>
SPGN 120408	4,00	<input type="checkbox"/>	<input type="checkbox"/>	<input type="checkbox"/>	<input type="checkbox"/>



Esempio d'ordine: CCGW 120404 HS33

N.B. Prezzo cad. per 5 pz. e più. Ordinativo minimo 3 pz. Per 3 e 4 pezzi considerare maggiorazione +10%

Vedi la descrizione delle leghe a pagina 6

- disponibile a stock
- disponibile in breve tempo su richiesta

**Inserti per tornitura**

S



Codice ISO	Quota SL	HS 61	HS 33	HS 62	CI 02
SPGW 070302	3,00	☐	☐	☐	☐
SPGW 070304	3,00	☐	☐	☐	☐
SPGW 090302	4,00	☐	☐	☐	☐
SPGW 090304	4,00	☐	☐	☐	☐
SPGW 090308	4,00	☐	☐	☐	☐
SPGW 09T302	4,00	☐	☐	☐	☐
SPGW 09T304	4,00	☐	☐	☐	☐
SPGW 09T308	4,00	☐	☐	☐	☐
SPGW 120402	4,00	☐	☐	☐	☐
SPGW 120404	4,00	☐	☐	☐	☐
SPGW 120408	4,00	☐	☐	☐	☐

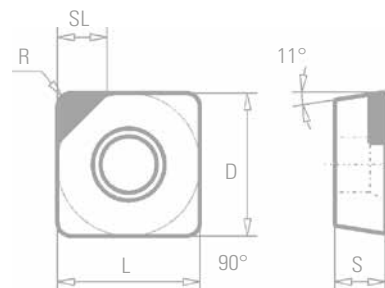

T



Codice ISO	Quota SL	HS 61	HS 33	HS 62	CI 02
TCGW 090202	3,00	☐	☐	☐	☐
TCGW 090204	3,00	☐	☐	☐	☐
TCGW 090208	3,00	☐	☐	☐	☐
TCGW 110202	4,00	☐	☐	☐	☐
TCGW 110204	4,00	☐	☐	☐	☐
TCGW 110208	4,00	☐	☐	☐	☐
TCGW 130404	4,00	☐	☐	☐	☐
TCGW 130408	4,00	☐	☐	☐	☐
TCGW 16T302	4,00	☐	☐	☐	☐
TCGW 16T304	4,00	☐	■	☐	■
TCGW 16T308	4,00	☐	■	☐	■
TCGW 16T312	4,00	☐	☐	☐	☐

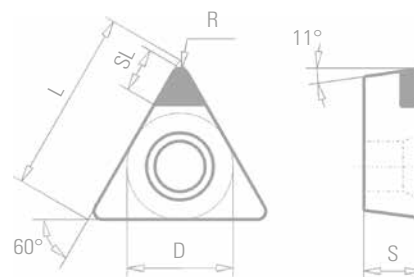

Codice	Quota SL	HS 61	HS 33	HS 62	CI 02
L-TCGW 090202	9,34	☐	☐	☐	☐
L-TCGW 090204	9,04	☐	☐	☐	☐
L-TCGW 110202	10,71	☐	☐	☐	☐
L-TCGW 110204	10,41	☐	☐	☐	☐
L-TCGW 110208	9,93	☐	☐	☐	☐
L-TCGW 16T302	16,20	☐	☐	☐	☐
L-TCGW 16T304	15,91	☐	☐	☐	☐
L-TCGW 16T308	15,33	☐	☐	☐	☐

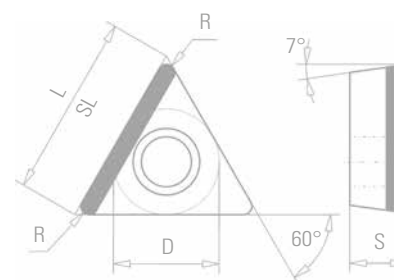

Codice	Quota SL	HS 61	HS 33	HS 62	CI 02
TNGN 110304	4,00	☐	☐	☐	☐
TNGN 110308	4,00	☐	☐	☐	☐
TNGN 130304	4,00	☐	☐	☐	☐
TNGN 130308	4,00	☐	☐	☐	☐
TNGN 160304	4,00	☐	☐	☐	☐
TNGN 160308	4,00	☐	☐	☐	☐
TNGN 160404	4,00	☐	☐	☐	☐
TNGN 160408	4,00	☐	☐	☐	☐

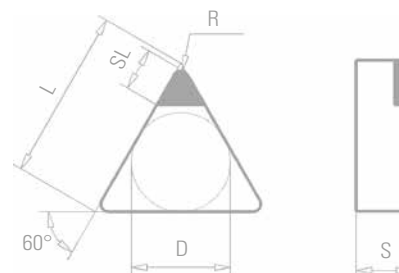

Esempio d'ordine: CCGW 120404 HS33

N.B. Prezzo cad. per 5 pz. e più. Ordinativo minimo 3 pz. Per 3 e 4 pezzi considerare maggiorazione +10%

Vedi la descrizione delle leghe a pagina 6

■ -disponibile a stock

☐ -disponibile in breve tempo su richiesta

**Inserti per tornitura**

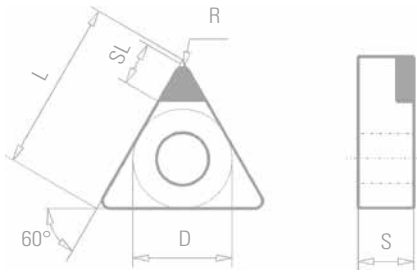

Codice ISO	Quota SL	HS 61	HS 33	HS 62	Cl 02
TNGA 110304	4,00	<input type="checkbox"/>	<input type="checkbox"/>	<input type="checkbox"/>	<input type="checkbox"/>
TNGA 110308	4,00	<input type="checkbox"/>	<input type="checkbox"/>	<input type="checkbox"/>	<input type="checkbox"/>
TNGA 160304	4,00	<input type="checkbox"/>	<input type="checkbox"/>	<input type="checkbox"/>	<input type="checkbox"/>
TNGA 160308	4,00	<input type="checkbox"/>	<input type="checkbox"/>	<input type="checkbox"/>	<input type="checkbox"/>
TNGA 160403	4,00	<input type="checkbox"/>	<input checked="" type="checkbox"/>	<input type="checkbox"/>	<input type="checkbox"/>
TNGA 160404	4,00	<input type="checkbox"/>	<input checked="" type="checkbox"/>	<input type="checkbox"/>	<input checked="" type="checkbox"/>
TNGA 160408	4,00	<input type="checkbox"/>	<input checked="" type="checkbox"/>	<input type="checkbox"/>	<input checked="" type="checkbox"/>
TNGA 160410	4,00	<input type="checkbox"/>	<input checked="" type="checkbox"/>	<input type="checkbox"/>	<input type="checkbox"/>
TNGA 160412	4,00	<input type="checkbox"/>	<input type="checkbox"/>	<input type="checkbox"/>	<input type="checkbox"/>
TNGA 220404	4,00	<input type="checkbox"/>	<input type="checkbox"/>	<input type="checkbox"/>	<input type="checkbox"/>
TNGA 220408	4,00	<input type="checkbox"/>	<input type="checkbox"/>	<input type="checkbox"/>	<input type="checkbox"/>

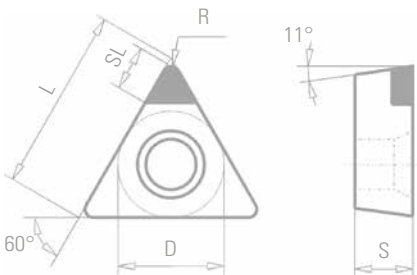

TPGW 110202	4,00	<input type="checkbox"/>	<input type="checkbox"/>	<input type="checkbox"/>	<input type="checkbox"/>
TPGW 110204	4,00	<input type="checkbox"/>	<input type="checkbox"/>	<input type="checkbox"/>	<input type="checkbox"/>
TPGW 110208	4,00	<input type="checkbox"/>	<input type="checkbox"/>	<input type="checkbox"/>	<input type="checkbox"/>
TPGW 110302	4,00	<input type="checkbox"/>	<input type="checkbox"/>	<input type="checkbox"/>	<input type="checkbox"/>
TPGW 110304	4,00	<input type="checkbox"/>	<input type="checkbox"/>	<input type="checkbox"/>	<input type="checkbox"/>
TPGW 110308	4,00	<input type="checkbox"/>	<input type="checkbox"/>	<input type="checkbox"/>	<input type="checkbox"/>
TPGW 16T304	4,00	<input type="checkbox"/>	<input type="checkbox"/>	<input type="checkbox"/>	<input type="checkbox"/>
TPGW 16T308	4,00	<input type="checkbox"/>	<input type="checkbox"/>	<input type="checkbox"/>	<input type="checkbox"/>
TPGW 160404	4,00	<input type="checkbox"/>	<input type="checkbox"/>	<input type="checkbox"/>	<input type="checkbox"/>
TPGW 160408	4,00	<input type="checkbox"/>	<input type="checkbox"/>	<input type="checkbox"/>	<input type="checkbox"/>

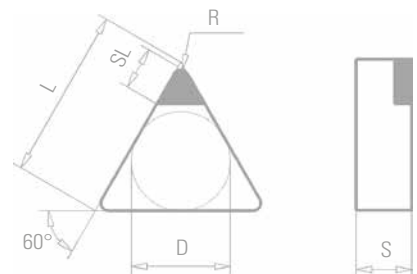

TPGN 090202	3,00	<input type="checkbox"/>	<input type="checkbox"/>	<input type="checkbox"/>	<input type="checkbox"/>
TPGN 090204	3,00	<input type="checkbox"/>	<input type="checkbox"/>	<input type="checkbox"/>	<input type="checkbox"/>
TPGN 090208	3,00	<input type="checkbox"/>	<input type="checkbox"/>	<input type="checkbox"/>	<input type="checkbox"/>
TPGN 110202	4,00	<input type="checkbox"/>	<input type="checkbox"/>	<input type="checkbox"/>	<input type="checkbox"/>
TPGN 110204	4,00	<input type="checkbox"/>	<input type="checkbox"/>	<input type="checkbox"/>	<input checked="" type="checkbox"/>
TPGN 110208	4,00	<input type="checkbox"/>	<input type="checkbox"/>	<input type="checkbox"/>	<input type="checkbox"/>
TPGN 110302	4,00	<input type="checkbox"/>	<input type="checkbox"/>	<input type="checkbox"/>	<input type="checkbox"/>
TPGN 110304	4,00	<input type="checkbox"/>	<input type="checkbox"/>	<input type="checkbox"/>	<input checked="" type="checkbox"/>
TPGN 110308	4,00	<input type="checkbox"/>	<input type="checkbox"/>	<input type="checkbox"/>	<input checked="" type="checkbox"/>
TPGN 160304	4,00	<input type="checkbox"/>	<input checked="" type="checkbox"/>	<input type="checkbox"/>	<input checked="" type="checkbox"/>
TPGN 160308	4,00	<input type="checkbox"/>	<input checked="" type="checkbox"/>	<input type="checkbox"/>	<input type="checkbox"/>



Esempio d'ordine: CCGW 120404 HS33

**N.B. Prezzo cad. per 5 pz. e più. Ordinativo minimo 3 pz. Per 3 e 4 pezzi considerare maggiorazione +10%**

Vedi la descrizione delle leghe a pagina 6

- disponibile a stock
- disponibile in breve tempo su richiesta

**Inserti per tornitura**

V



Codice ISO	Quota SL	HS 61	HS 33	HS 62	CI 02
VBGW 110201	3,70	<input type="checkbox"/>	<input type="checkbox"/>	<input type="checkbox"/>	<input type="checkbox"/>
VBGW 110202	3,70	<input type="checkbox"/>	<input type="checkbox"/>	<input type="checkbox"/>	<input type="checkbox"/>
VBGW 110204	3,70	<input type="checkbox"/>	<input type="checkbox"/>	<input type="checkbox"/>	<input type="checkbox"/>
VBGW 110302	3,70	<input type="checkbox"/>	<input type="checkbox"/>	<input type="checkbox"/>	<input type="checkbox"/>
VBGW 110304	3,70	<input type="checkbox"/>	<input type="checkbox"/>	<input type="checkbox"/>	<input type="checkbox"/>
VBGW 110308	3,70	<input type="checkbox"/>	<input type="checkbox"/>	<input type="checkbox"/>	<input type="checkbox"/>
VBGW 160402	4,50	<input type="checkbox"/>	<input type="checkbox"/>	<input type="checkbox"/>	<input type="checkbox"/>
VBGW 160404	4,50	<input type="checkbox"/>	<input checked="" type="checkbox"/>	<input type="checkbox"/>	<input checked="" type="checkbox"/>
VBGW 160406	4,50	<input type="checkbox"/>	<input type="checkbox"/>	<input type="checkbox"/>	<input type="checkbox"/>
VBGW 160408	4,50	<input type="checkbox"/>	<input checked="" type="checkbox"/>	<input type="checkbox"/>	<input checked="" type="checkbox"/>
VBGW 160412	4,50	<input type="checkbox"/>	<input type="checkbox"/>	<input type="checkbox"/>	<input type="checkbox"/>

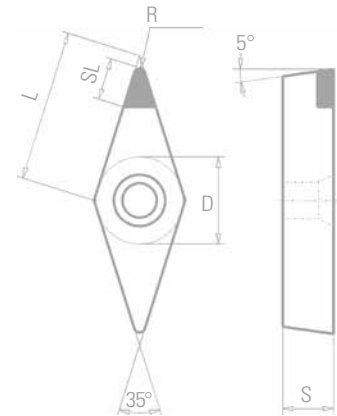

VCGW 070202	3,70	<input type="checkbox"/>	<input type="checkbox"/>	<input type="checkbox"/>	<input type="checkbox"/>
VCGW 070204	3,70	<input type="checkbox"/>	<input type="checkbox"/>	<input type="checkbox"/>	<input type="checkbox"/>
VCGW 070208	3,70	<input type="checkbox"/>	<input type="checkbox"/>	<input type="checkbox"/>	<input type="checkbox"/>
VCGW 110302	3,70	<input type="checkbox"/>	<input checked="" type="checkbox"/>	<input type="checkbox"/>	<input type="checkbox"/>
VCGW 110304	3,70	<input type="checkbox"/>	<input checked="" type="checkbox"/>	<input type="checkbox"/>	<input type="checkbox"/>
VCGW 110308	3,70	<input type="checkbox"/>	<input type="checkbox"/>	<input type="checkbox"/>	<input type="checkbox"/>
VCGW 130302	3,70	<input type="checkbox"/>	<input type="checkbox"/>	<input type="checkbox"/>	<input type="checkbox"/>
VCGW 130304	3,70	<input type="checkbox"/>	<input type="checkbox"/>	<input type="checkbox"/>	<input type="checkbox"/>
VCGW 160402	4,50	<input type="checkbox"/>	<input type="checkbox"/>	<input type="checkbox"/>	<input type="checkbox"/>
VCGW 160404	4,50	<input type="checkbox"/>	<input checked="" type="checkbox"/>	<input type="checkbox"/>	<input type="checkbox"/>
VCGW 160408	4,50	<input type="checkbox"/>	<input checked="" type="checkbox"/>	<input type="checkbox"/>	<input type="checkbox"/>
VCGW 160412	4,50	<input type="checkbox"/>	<input type="checkbox"/>	<input type="checkbox"/>	<input type="checkbox"/>

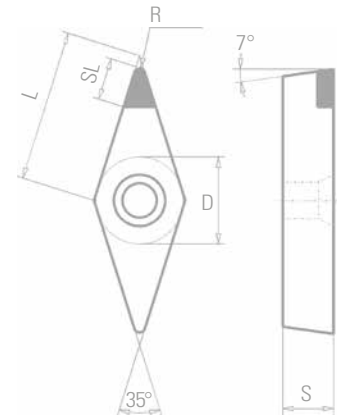

VNGA 160402	4,50	<input type="checkbox"/>	<input checked="" type="checkbox"/>	<input type="checkbox"/>	<input type="checkbox"/>
VNGA 160403	4,50	<input type="checkbox"/>	<input type="checkbox"/>	<input type="checkbox"/>	<input type="checkbox"/>
VNGA 160404	4,50	<input type="checkbox"/>	<input checked="" type="checkbox"/>	<input type="checkbox"/>	<input checked="" type="checkbox"/>
VNGA 160406	4,50	<input type="checkbox"/>	<input type="checkbox"/>	<input type="checkbox"/>	<input type="checkbox"/>
VNGA 160408	4,50	<input type="checkbox"/>	<input checked="" type="checkbox"/>	<input type="checkbox"/>	<input checked="" type="checkbox"/>
VNGA 160410	4,50	<input type="checkbox"/>	<input type="checkbox"/>	<input type="checkbox"/>	<input type="checkbox"/>
VNGA 160412	4,50	<input type="checkbox"/>	<input checked="" type="checkbox"/>	<input type="checkbox"/>	<input type="checkbox"/>

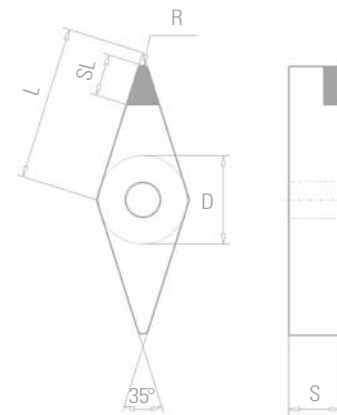

W



Codice ISO	Quota SL	HS 61	HS 33	HS 62	CI 02
WNGA 080404	4,00	<input type="checkbox"/>	<input type="checkbox"/>	<input type="checkbox"/>	<input type="checkbox"/>
WNGA 080408	4,00	<input type="checkbox"/>	<input type="checkbox"/>	<input type="checkbox"/>	<input type="checkbox"/>
WNGA 080412	4,00	<input type="checkbox"/>	<input type="checkbox"/>	<input type="checkbox"/>	<input type="checkbox"/>

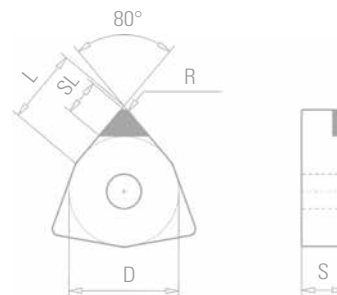

**Esempio d'ordine: CCGW 120404 HS33 N.B. Prezzo cad. per 5 pz. e più. Ordinativo minimo 3 pz. Per 3 e 4 pezzi considerare maggiorazione +10%**

Vedi la descrizione delle leghe a pagina 6

- disponibile a stock
- disponibile in breve tempo su richiesta

**Inserti per tornitura con mini riporto**

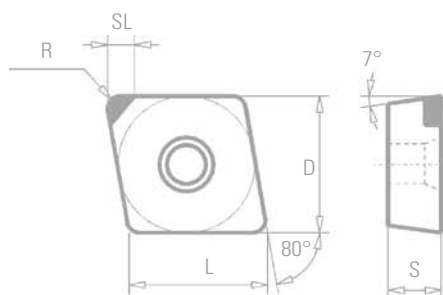

Codice ISO	Quota SL	HS 61	HS 33	HS 62	Cl 02
E-CCGW 060202	2,70	☐	☐	☐	☐
E-CCGW 060204	2,70	☐	☐	☐	☐
E-CCGW 09T302	2,70	☐	☐	☐	☐
E-CCGW 09T304	2,70	☐	■	☐	■
E-CCGW 09T308	2,70	☐	■	☐	■
E-CCGW 120402	2,70	☐	☐	☐	☐
E-CCGW 120404	2,70	☐	■	☐	■
E-CCGW 120408	2,70	☐	■	☐	☐

Geometria Wiper destra e sinistra				
EW-CCGW 060202	2,70	☐		
EW-CCGW 060204	2,70	☐		
EW-CCGW 09T304	2,70	☐		
EW-CCGW 09T308	2,70	☐		

D-CCGW 09T304	2,70	☐	■	☐	■
D-CCGW 09T308	2,70	☐	■	☐	■
D-CCGW 120404	2,70	☐	■	☐	■
D-CCGW 120408	2,70	☐	☐	☐	☐

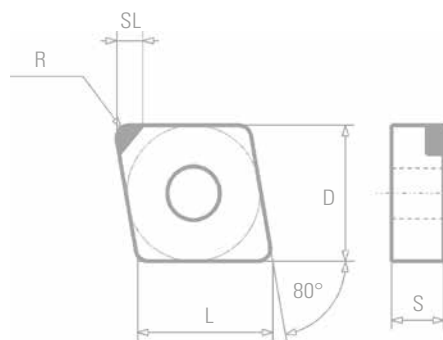

E-CNGA 120402	2,70	☐	■	☐	☐
E-CNGA 120404	2,70	☐	■	☐	■
E-CNGA 120408	2,70	☐	■	☐	■
E-CNGA 120412	2,70	☐	■	☐	■

Geometria Wiper destra e sinistra					
EW-CNGA 120404	2,70	☐	☐	☐	☐
EW-CNGA 120408	2,70	☐	☐	☐	☐

D-CNGA 120402	2,70	☐	☐	☐	☐
D-CNGA 120404	2,70	☐	■	☐	■
D-CNGA 120408	2,70	☐	■	☐	■

Geometria Wiper destra e sinistra					
DW-CNGA 120408	2,70	☐	☐	☐	☐

Mini riporto wiper



Due taglienti

Esempio d'ordine: CCGW 120404 HS33

**N.B. Prezzo cad. per 5 pz. e più. Ordinativo minimo 3 pz. Per 3 e 4 pezzi considerare maggiorazione +10%**

Vedi la descrizione delle leghe a pagina 6

- -disponibile a stock
- ☐ -disponibile in breve tempo su richiesta



**Inserti per tornitura con mini riporto**

Mini riporto wiper

**D**



Codice ISO	Quota SL	HS 61	HS 33	HS 62	CI 02
E-DCGW 070202	2,70	<input type="checkbox"/>	<input checked="" type="checkbox"/>	<input type="checkbox"/>	<input checked="" type="checkbox"/>
E-DCGW 070204	2,70	<input type="checkbox"/>	<input checked="" type="checkbox"/>	<input type="checkbox"/>	<input checked="" type="checkbox"/>
E-DCGW 11T302	2,70	<input type="checkbox"/>	<input checked="" type="checkbox"/>	<input type="checkbox"/>	<input checked="" type="checkbox"/>
E-DCGW 11T304	2,70	<input type="checkbox"/>	<input checked="" type="checkbox"/>	<input type="checkbox"/>	<input checked="" type="checkbox"/>
E-DCGW 11T308	2,70	<input type="checkbox"/>	<input checked="" type="checkbox"/>	<input type="checkbox"/>	<input checked="" type="checkbox"/>



D-DCGW 070202	2,70	<input type="checkbox"/>	<input checked="" type="checkbox"/>	<input type="checkbox"/>	<input checked="" type="checkbox"/>
D-DCGW 070204	2,70	<input type="checkbox"/>	<input checked="" type="checkbox"/>	<input type="checkbox"/>	<input checked="" type="checkbox"/>
D-DCGW 11T302	2,70	<input type="checkbox"/>	<input checked="" type="checkbox"/>	<input type="checkbox"/>	<input type="checkbox"/>
D-DCGW 11T304	2,70	<input type="checkbox"/>	<input checked="" type="checkbox"/>	<input type="checkbox"/>	<input checked="" type="checkbox"/>
D-DCGW 11T308	2,70	<input type="checkbox"/>	<input checked="" type="checkbox"/>	<input type="checkbox"/>	<input checked="" type="checkbox"/>



E-DNGA 150402	2,70	<input type="checkbox"/>	<input type="checkbox"/>	<input type="checkbox"/>	<input type="checkbox"/>
E-DNGA 150404	2,70	<input type="checkbox"/>	<input checked="" type="checkbox"/>	<input type="checkbox"/>	<input checked="" type="checkbox"/>
E-DNGA 150408	2,70	<input type="checkbox"/>	<input checked="" type="checkbox"/>	<input type="checkbox"/>	<input type="checkbox"/>
E-DNGA 150602	2,70	<input type="checkbox"/>	<input type="checkbox"/>	<input type="checkbox"/>	<input checked="" type="checkbox"/>
E-DNGA 150604	2,70	<input type="checkbox"/>	<input checked="" type="checkbox"/>	<input type="checkbox"/>	<input checked="" type="checkbox"/>
E-DNGA 150608	2,70	<input type="checkbox"/>	<input checked="" type="checkbox"/>	<input type="checkbox"/>	<input type="checkbox"/>

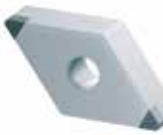

D-DNGA 110404	2,70	<input type="checkbox"/>	<input checked="" type="checkbox"/>	<input type="checkbox"/>	<input type="checkbox"/>
D-DNGA 110408	2,70	<input type="checkbox"/>	<input checked="" type="checkbox"/>	<input type="checkbox"/>	<input type="checkbox"/>
D-DNGA 150604	2,70	<input type="checkbox"/>	<input checked="" type="checkbox"/>	<input type="checkbox"/>	<input checked="" type="checkbox"/>
D-DNGA 150608	2,70	<input type="checkbox"/>	<input checked="" type="checkbox"/>	<input type="checkbox"/>	<input checked="" type="checkbox"/>



Geometria Wiper a 93°*		HS 61	HS 33	HS 62	CI 02
EW-DCGW 11T304 R	2,70	<input type="checkbox"/>	<input type="checkbox"/>	<input type="checkbox"/>	<input type="checkbox"/>
EW-DCGW 11T304 L	2,70	<input type="checkbox"/>	<input type="checkbox"/>	<input type="checkbox"/>	<input type="checkbox"/>
EW-DCGW 11T308 R	2,70	<input type="checkbox"/>	<input type="checkbox"/>	<input type="checkbox"/>	<input type="checkbox"/>
EW-DCGW 11T308 L	2,70	<input type="checkbox"/>	<input type="checkbox"/>	<input type="checkbox"/>	<input type="checkbox"/>



Due taglienti

Geometria Wiper a 93°*		HS 61	HS 33	HS 62	CI 02
DW-DCGW 11T304 R	2,70	<input type="checkbox"/>	<input type="checkbox"/>	<input type="checkbox"/>	<input type="checkbox"/>
DW-DCGW 11T304 L	2,70	<input type="checkbox"/>	<input type="checkbox"/>	<input type="checkbox"/>	<input type="checkbox"/>
DW-DCGW 11T308 R	2,70	<input type="checkbox"/>	<input type="checkbox"/>	<input type="checkbox"/>	<input type="checkbox"/>
DW-DCGW 11T308 L	2,70	<input type="checkbox"/>	<input type="checkbox"/>	<input type="checkbox"/>	<input type="checkbox"/>

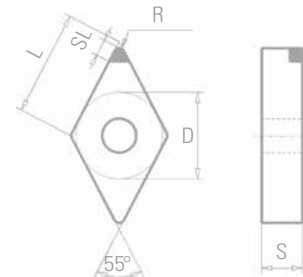
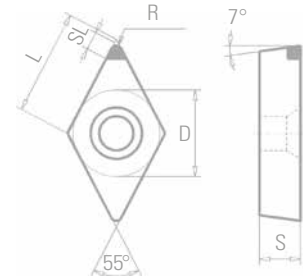

\*In riferimento agli inserti EW e DW-DCGW, la geometria Wiper lavora unicamente quando l'inserto è montato su portainserito a 93°

**Inserti per tornitura con mini riporto**

Mini riporto  
**S**

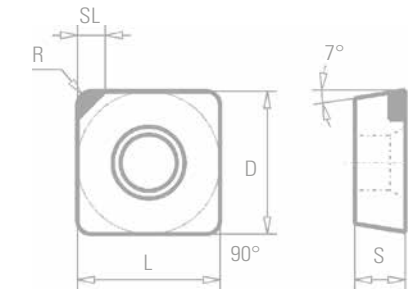

Codice ISO	Quota SL	HS 61	HS 33	HS 62	CI 02
E-SCGW 09T302	2,70	<input type="checkbox"/>	<input type="checkbox"/>	<input type="checkbox"/>	<input type="checkbox"/>
E-SCGW 09T304	2,70	<input type="checkbox"/>	<input type="checkbox"/>	<input type="checkbox"/>	<input type="checkbox"/>
E-SCGW 09T308	2,70	<input type="checkbox"/>	<input type="checkbox"/>	<input type="checkbox"/>	<input type="checkbox"/>
E-SCGW 120404	2,70	<input type="checkbox"/>	<input type="checkbox"/>	<input type="checkbox"/>	<input type="checkbox"/>
E-SCGW 120408	2,70	<input type="checkbox"/>	<input type="checkbox"/>	<input type="checkbox"/>	<input checked="" type="checkbox"/>
E-SCGW 120412	2,70	<input type="checkbox"/>	<input type="checkbox"/>	<input type="checkbox"/>	<input type="checkbox"/>

Q-SCGW 120404	2,70	<input type="checkbox"/>	<input type="checkbox"/>	<input type="checkbox"/>	<input type="checkbox"/>
Q-SCGW 120408	2,70	<input type="checkbox"/>	<input type="checkbox"/>	<input type="checkbox"/>	<input type="checkbox"/>

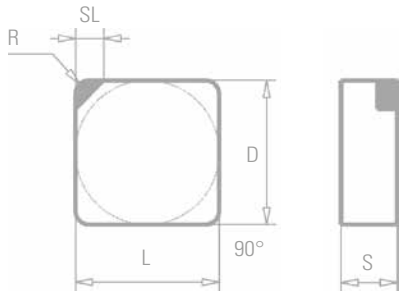

E-SNGN 120404	2,70	<input type="checkbox"/>	<input type="checkbox"/>	<input type="checkbox"/>	<input type="checkbox"/>
E-SNGN 120408	2,70	<input type="checkbox"/>	<input type="checkbox"/>	<input type="checkbox"/>	<input type="checkbox"/>

Q-SNGN 120404	2,70	<input type="checkbox"/>	<input type="checkbox"/>	<input type="checkbox"/>	<input type="checkbox"/>
Q-SNGN 120408	2,70	<input type="checkbox"/>	<input type="checkbox"/>	<input type="checkbox"/>	<input type="checkbox"/>

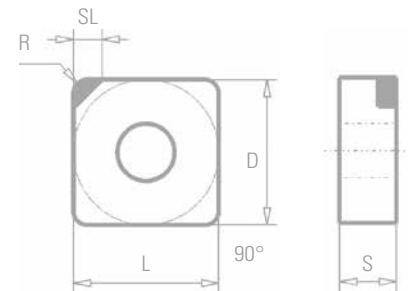

E-SNGA 120404	2,70	<input type="checkbox"/>	<input type="checkbox"/>	<input type="checkbox"/>	<input type="checkbox"/>
E-SNGA 120408	2,70	<input type="checkbox"/>	<input type="checkbox"/>	<input type="checkbox"/>	<input type="checkbox"/>

Q-SNGA 120404	2,70	<input type="checkbox"/>	<input type="checkbox"/>	<input type="checkbox"/>	<input type="checkbox"/>
Q-SNGA 120408	2,70	<input type="checkbox"/>	<input type="checkbox"/>	<input type="checkbox"/>	<input checked="" type="checkbox"/>

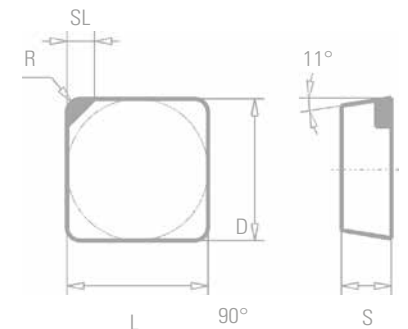

E-SPGN 120304	2,70	<input type="checkbox"/>	<input type="checkbox"/>	<input type="checkbox"/>	<input type="checkbox"/>
E-SPGN 120308	2,70	<input type="checkbox"/>	<input type="checkbox"/>	<input type="checkbox"/>	<input type="checkbox"/>
E-SPGN 120404	2,70	<input type="checkbox"/>	<input type="checkbox"/>	<input type="checkbox"/>	<input type="checkbox"/>
E-SPGN 120408	2,70	<input type="checkbox"/>	<input type="checkbox"/>	<input type="checkbox"/>	<input type="checkbox"/>

Q-SPGN 120304	2,70	<input type="checkbox"/>	<input type="checkbox"/>	<input type="checkbox"/>	<input type="checkbox"/>
Q-SPGN 120308	2,70	<input type="checkbox"/>	<input type="checkbox"/>	<input type="checkbox"/>	<input type="checkbox"/>
Q-SPGN 120404	2,70	<input type="checkbox"/>	<input type="checkbox"/>	<input type="checkbox"/>	<input type="checkbox"/>
Q-SPGN 120408	2,70	<input type="checkbox"/>	<input type="checkbox"/>	<input type="checkbox"/>	<input type="checkbox"/>

Esempio d'ordine: CCGW 120404 HS33

**N.B. Prezzo cad. per 5 pz. e più. Ordinativo minimo 3 pz. Per 3 e 4 pezzi considerare maggiorazione +10%**

Vedi la descrizione delle leghe a pagina 6

- disponibile a stock
- disponibile in breve tempo su richiesta

**Inserti per tornitura con mini riporto**

Mini riporto



Codice ISO	Quota SL	HS 61	HS 33	HS 62	CI 02
E-TCGW 090202	2,70	<input type="checkbox"/>	<input type="checkbox"/>	<input type="checkbox"/>	<input type="checkbox"/>
E-TCGW 090204	2,70	<input type="checkbox"/>	<input type="checkbox"/>	<input type="checkbox"/>	<input type="checkbox"/>
E-TCGW 110202	2,70	<input type="checkbox"/>	<input checked="" type="checkbox"/>	<input type="checkbox"/>	<input checked="" type="checkbox"/>
E-TCGW 110204	2,70	<input type="checkbox"/>	<input checked="" type="checkbox"/>	<input type="checkbox"/>	<input checked="" type="checkbox"/>
E-TCGW 110208	2,70	<input type="checkbox"/>	<input checked="" type="checkbox"/>	<input type="checkbox"/>	<input type="checkbox"/>
E-TCGW 130304	2,70	<input type="checkbox"/>	<input type="checkbox"/>	<input type="checkbox"/>	<input type="checkbox"/>
E-TCGW 130308	2,70	<input type="checkbox"/>	<input type="checkbox"/>	<input type="checkbox"/>	<input type="checkbox"/>
E-TCGW 16T302	2,70	<input type="checkbox"/>	<input type="checkbox"/>	<input type="checkbox"/>	<input type="checkbox"/>
E-TCGW 16T304	2,70	<input type="checkbox"/>	<input checked="" type="checkbox"/>	<input type="checkbox"/>	<input checked="" type="checkbox"/>
E-TCGW 16T308	2,70	<input type="checkbox"/>	<input checked="" type="checkbox"/>	<input type="checkbox"/>	<input checked="" type="checkbox"/>
E-TCGW 16T312	2,70	<input type="checkbox"/>	<input type="checkbox"/>	<input type="checkbox"/>	<input type="checkbox"/>

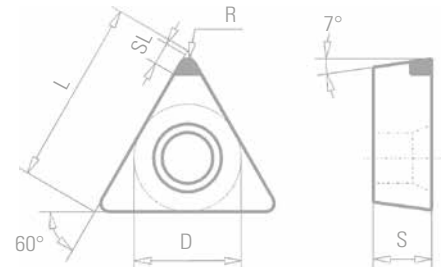

T-TCGW 16T304	2,70	<input type="checkbox"/>	<input type="checkbox"/>	<input type="checkbox"/>	<input type="checkbox"/>
T-TCGW 16T308	2,70	<input type="checkbox"/>	<input type="checkbox"/>	<input type="checkbox"/>	<input type="checkbox"/>



E-TNGA 160404	2,70	<input type="checkbox"/>	<input type="checkbox"/>	<input type="checkbox"/>	<input type="checkbox"/>
E-TNGA 160408	2,70	<input type="checkbox"/>	<input checked="" type="checkbox"/>	<input type="checkbox"/>	<input checked="" type="checkbox"/>

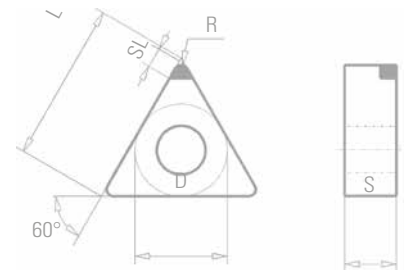

T-TNGA 160404	2,70	<input type="checkbox"/>	<input checked="" type="checkbox"/>	<input type="checkbox"/>	<input checked="" type="checkbox"/>
T-TNGA 160408	2,70	<input type="checkbox"/>	<input type="checkbox"/>	<input type="checkbox"/>	<input checked="" type="checkbox"/>



E-TPGN 110202	2,70	<input type="checkbox"/>	<input type="checkbox"/>	<input type="checkbox"/>	<input type="checkbox"/>
E-TPGN 110204	2,70	<input type="checkbox"/>	<input type="checkbox"/>	<input type="checkbox"/>	<input type="checkbox"/>
E-TPGN 110208	2,70	<input type="checkbox"/>	<input type="checkbox"/>	<input type="checkbox"/>	<input type="checkbox"/>
E-TPGN 110302	2,70	<input type="checkbox"/>	<input type="checkbox"/>	<input type="checkbox"/>	<input type="checkbox"/>
E-TPGN 110304	2,70	<input type="checkbox"/>	<input type="checkbox"/>	<input type="checkbox"/>	<input type="checkbox"/>
E-TPGN 110308	2,70	<input type="checkbox"/>	<input type="checkbox"/>	<input type="checkbox"/>	<input type="checkbox"/>
E-TPGN 160304	2,70	<input type="checkbox"/>	<input type="checkbox"/>	<input type="checkbox"/>	<input type="checkbox"/>
E-TPGN 160308	2,70	<input type="checkbox"/>	<input type="checkbox"/>	<input type="checkbox"/>	<input type="checkbox"/>

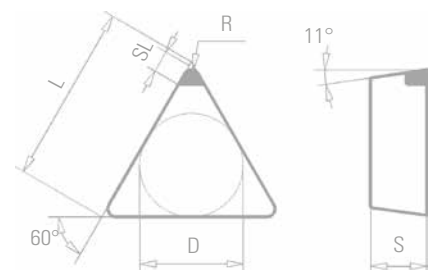

E-TPGW 110202	2,70	<input type="checkbox"/>	<input type="checkbox"/>	<input type="checkbox"/>	<input type="checkbox"/>
E-TPGW 110204	2,70	<input type="checkbox"/>	<input type="checkbox"/>	<input type="checkbox"/>	<input type="checkbox"/>
E-TPGW 110302	2,70	<input type="checkbox"/>	<input type="checkbox"/>	<input type="checkbox"/>	<input type="checkbox"/>
E-TPGW 110304	2,70	<input type="checkbox"/>	<input type="checkbox"/>	<input type="checkbox"/>	<input type="checkbox"/>



T-TPGN 160304	2,70	<input type="checkbox"/>	<input type="checkbox"/>	<input type="checkbox"/>	<input type="checkbox"/>
T-TPGN 160308	2,70	<input type="checkbox"/>	<input type="checkbox"/>	<input type="checkbox"/>	<input type="checkbox"/>

Esempio d'ordine: CCGW 120404 HS33

N.B. Prezzo cad. per 5 pz. e più. Ordinativo minimo 3 pz. Per 3 e 4 pezzi considerare maggiorazione +10%

Vedi la descrizione delle leghe a pagina 6

■ -disponibile a stock

□ -disponibile in breve tempo su richiesta

**Inserti per tornitura con mini riporto**

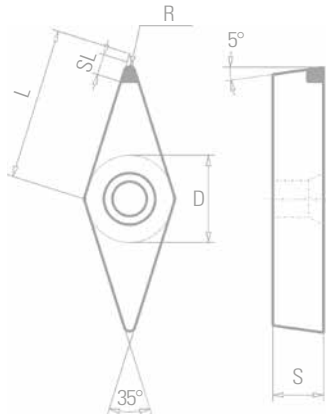

Codice ISO	Quota SL	HS 61	HS 33	HS 62	CI 02
E-VBGW 110201	3,00	<input type="checkbox"/>	<input type="checkbox"/>	<input type="checkbox"/>	<input checked="" type="checkbox"/>
E-VBGW 110202	3,00	<input type="checkbox"/>	<input type="checkbox"/>	<input type="checkbox"/>	<input checked="" type="checkbox"/>
E-VBGW 110204	3,00	<input type="checkbox"/>	<input type="checkbox"/>	<input type="checkbox"/>	<input checked="" type="checkbox"/>
E-VBGW 160402	3,00	<input type="checkbox"/>	<input type="checkbox"/>	<input type="checkbox"/>	<input type="checkbox"/>
E-VBGW 160404	3,00	<input type="checkbox"/>	<input checked="" type="checkbox"/>	<input type="checkbox"/>	<input checked="" type="checkbox"/>
E-VBGW 160408	3,00	<input type="checkbox"/>	<input checked="" type="checkbox"/>	<input type="checkbox"/>	<input checked="" type="checkbox"/>
E-VBGW 160412	3,00	<input type="checkbox"/>	<input type="checkbox"/>	<input type="checkbox"/>	<input type="checkbox"/>

D-VBGW 160402	3,00	<input type="checkbox"/>	<input type="checkbox"/>	<input type="checkbox"/>	<input type="checkbox"/>
D-VBGW 160404	3,00	<input type="checkbox"/>	<input checked="" type="checkbox"/>	<input type="checkbox"/>	<input type="checkbox"/>
D-VBGW 160408	3,00	<input type="checkbox"/>	<input type="checkbox"/>	<input type="checkbox"/>	<input checked="" type="checkbox"/>

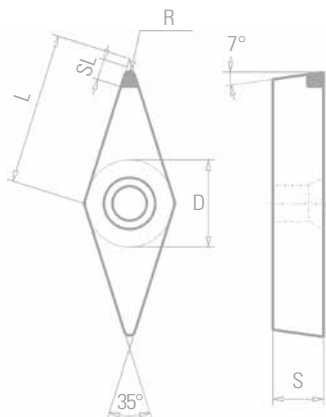

E-VCGW 110302	3,00	<input type="checkbox"/>	<input type="checkbox"/>	<input type="checkbox"/>	<input type="checkbox"/>
E-VCGW 110304	3,00	<input type="checkbox"/>	<input type="checkbox"/>	<input type="checkbox"/>	<input type="checkbox"/>
E-VCGW 160402	3,00	<input type="checkbox"/>	<input type="checkbox"/>	<input type="checkbox"/>	<input type="checkbox"/>
E-VCGW 160404	3,00	<input type="checkbox"/>	<input checked="" type="checkbox"/>	<input type="checkbox"/>	<input checked="" type="checkbox"/>
E-VCGW 160408	3,00	<input type="checkbox"/>	<input checked="" type="checkbox"/>	<input type="checkbox"/>	<input checked="" type="checkbox"/>
E-VCGW 160412	3,00	<input type="checkbox"/>	<input checked="" type="checkbox"/>	<input type="checkbox"/>	<input type="checkbox"/>

D-VCGW 110302	3,00	<input type="checkbox"/>	<input type="checkbox"/>	<input type="checkbox"/>	<input type="checkbox"/>
D-VCGW 110304	3,00	<input type="checkbox"/>	<input checked="" type="checkbox"/>	<input type="checkbox"/>	<input type="checkbox"/>
D-VCGW 130302	3,00	<input type="checkbox"/>	<input type="checkbox"/>	<input type="checkbox"/>	<input type="checkbox"/>
D-VCGW 130304	3,00	<input type="checkbox"/>	<input type="checkbox"/>	<input type="checkbox"/>	<input type="checkbox"/>
D-VCGW 160404	3,00	<input type="checkbox"/>	<input checked="" type="checkbox"/>	<input type="checkbox"/>	<input checked="" type="checkbox"/>
D-VCGW 160408	3,00	<input type="checkbox"/>	<input checked="" type="checkbox"/>	<input type="checkbox"/>	<input type="checkbox"/>

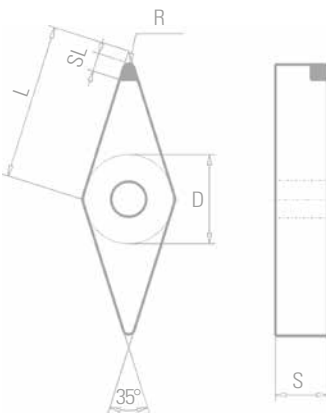

E-VNGA 160402	3,00	<input type="checkbox"/>	<input type="checkbox"/>	<input type="checkbox"/>	<input type="checkbox"/>
E-VNGA 160404	3,00	<input type="checkbox"/>	<input checked="" type="checkbox"/>	<input type="checkbox"/>	<input checked="" type="checkbox"/>
E-VNGA 160408	3,00	<input type="checkbox"/>	<input type="checkbox"/>	<input type="checkbox"/>	<input type="checkbox"/>

D-VNGA 160402	3,00	<input type="checkbox"/>	<input type="checkbox"/>	<input type="checkbox"/>	<input type="checkbox"/>
D-VNGA 160404	3,00	<input type="checkbox"/>	<input checked="" type="checkbox"/>	<input type="checkbox"/>	<input checked="" type="checkbox"/>
D-VNGA 160408	3,00	<input type="checkbox"/>	<input checked="" type="checkbox"/>	<input type="checkbox"/>	<input type="checkbox"/>

Mini riporto



**Esempio d'ordine: CCGW 120404 HS33**

Vedi la descrizione delle leghe a pagina 6

**N.B. Prezzo cad. per 5 pz. e più. Ordinativo minimo 3 pz. Per 3 e 4 pezzi considerare maggiorazione +10%**

-disponibile a stock

-disponibile in breve tempo su richiesta