

TAGLIENTI CON REFRIGERAZIONE RADIALE E ASSIALE DELLA SERIE 5000

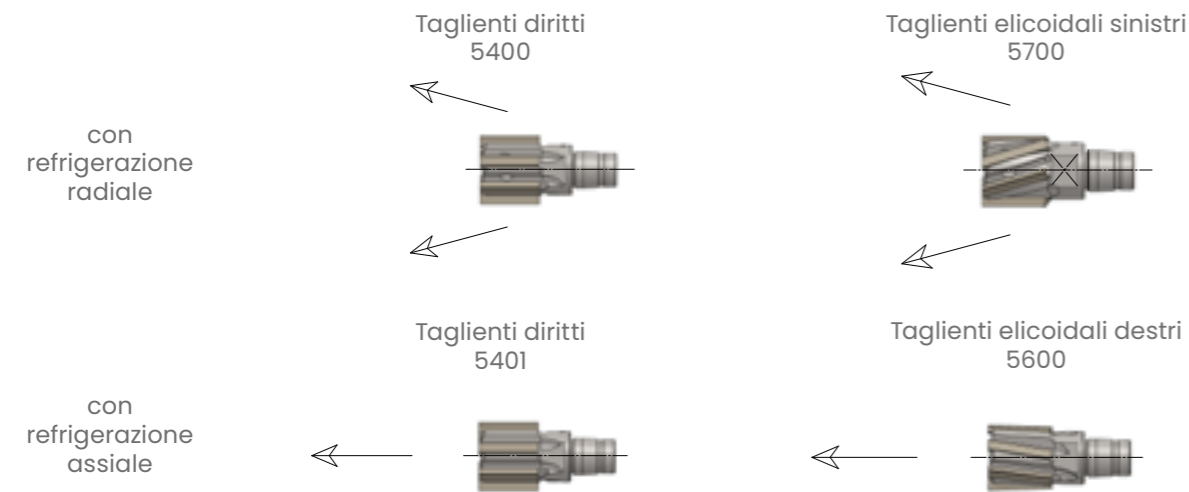

ANGOLI D'IMBOCCO PER TESTINE SERIE 5000

Taglienti diritti per alesare sia fori passanti che ciechi

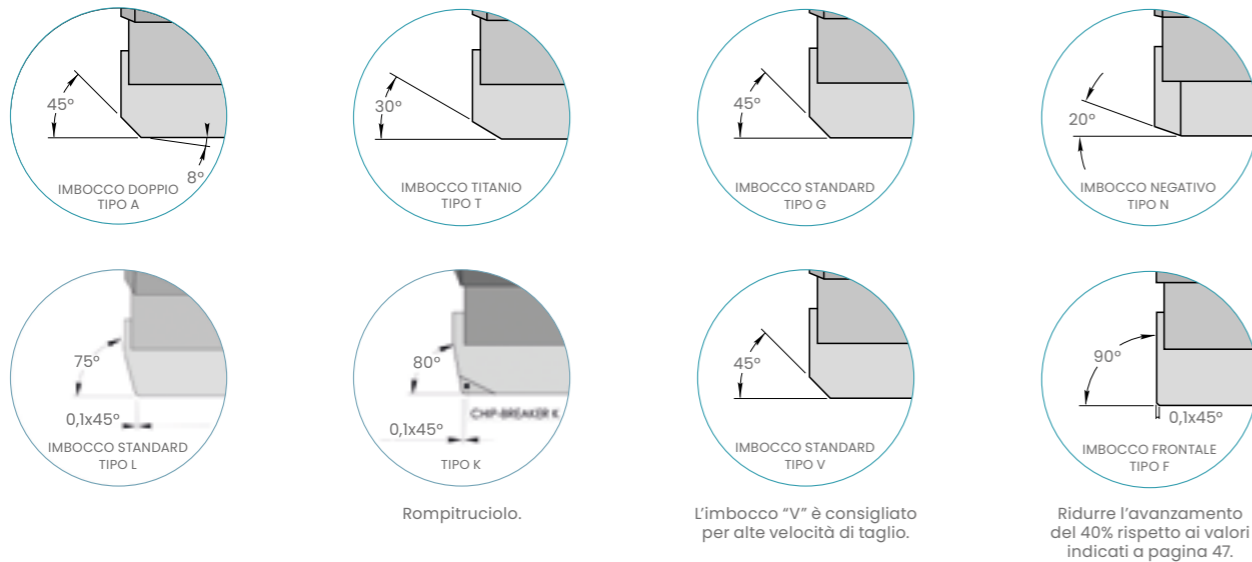

Taglienti elicoidali sinistri e destri

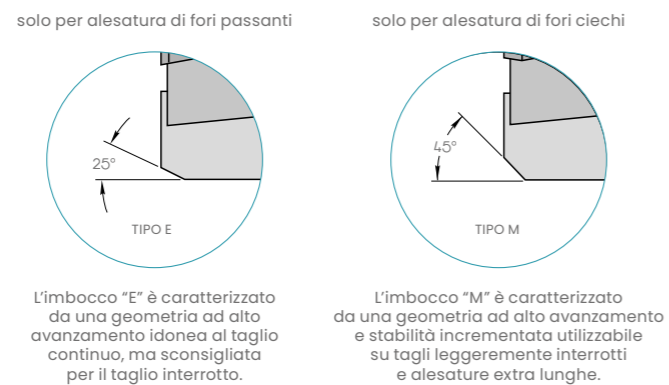

DESCRIZIONE DELLA CODIFICA

serie

5400 Taglienti diritti con refrigerazione radiale
 5401 Taglienti diritti con refrigerazione assiale
 5600 Taglienti elicoidali destri con refrigerazione assiale
 5700 Taglienti elicoidali sinistri con refrigerazione radiale

5400 - KL G X - 020000 H8

imbocco

diametro e tolleranza

materiale da taglio e rivestimento

R = esecuzione rompitruciolo
 H = fascia cilindrica di dimensione dimezzata
 Z = esecuzione rastremazione maggiorata

CODICE	DESCRIZIONE
KL	TAGLIENTI IN METALLO DURO
KN	TAGLIENTI IN METALLO DURO RIVESTITO IN N
KC	TAGLIENTI IN METALLO DURO RIVESTITO IN C
KA	TAGLIENTI IN METALLO DURO RIVESTITO IN A
KK	TAGLIENTI IN METALLO DURO RIVESTITI IN K
SV	TAGLIENTI IN CERMET
SN	TAGLIENTI IN CERMET RIVESTITI N
SC	TAGLIENTI IN CERMET RIVESTITI C
SA	TAGLIENTI IN CERMET RIVESTITI A
SK	TAGLIENTI IN CERMET RIVESTITI K



SERIE 5000-MC | ATTACCO CILINDRICO | SERIE CORTA

FORI PASSANTI

Refrigerazione Radiale

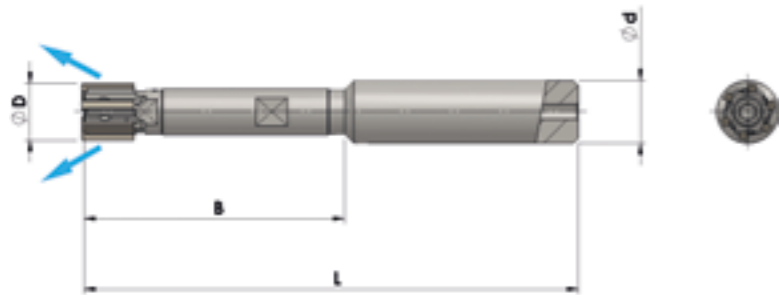

FORI CIECHI

Refrigerazione Assiale

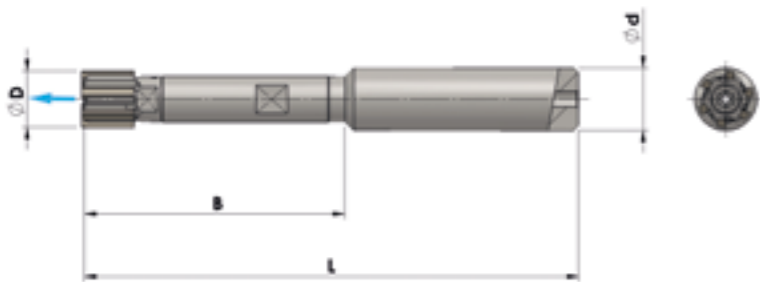

CODICE MANDRINO	Ø D mm	B mm	L mm	Ø d ^{h6} mm
5000-MC-001	9,60÷11,60	50	95	12
5000-MC-002	11,61÷14,60	50	95	12
5000-MC-003	14,61÷17,60	65	113	16
5000-MC-004	17,61÷21,60	75	125	20
5000-MC-005	21,61÷26,60	85	135	20
5000-MC-006	26,61÷32,60	105	161	25

SERIE 5000-ML | ATTACCO CILINDRICO | SERIE LUNGA

FORI PASSANTI

Refrigerazione Radiale



FORI CIECHI

Refrigerazione Assiale

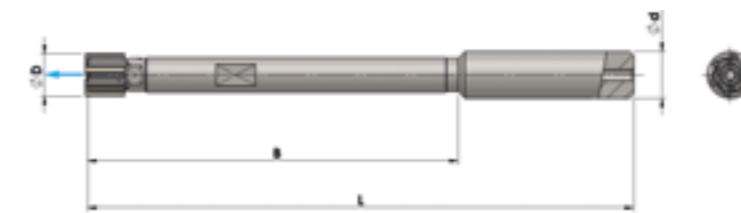

CODICE MANDRINO	Ø D mm	B mm	L mm	Ø d ^{h6} mm
5000-ML-001	9,60÷11,60	95	140	12
5000-ML-002	11,61÷14,60	95	140	12
5000-ML-003	14,61÷17,60	105	153	16
5000-ML-004	17,61÷21,60	125	175	20
5000-ML-005	21,61÷26,60	145	195	20
5000-ML-006	26,61÷32,60	165	221	25



SERIE 5000-MM | ATTACCO MODULARE COMPOSITO

FORI PASSANTI

Refrigerazione Radiale

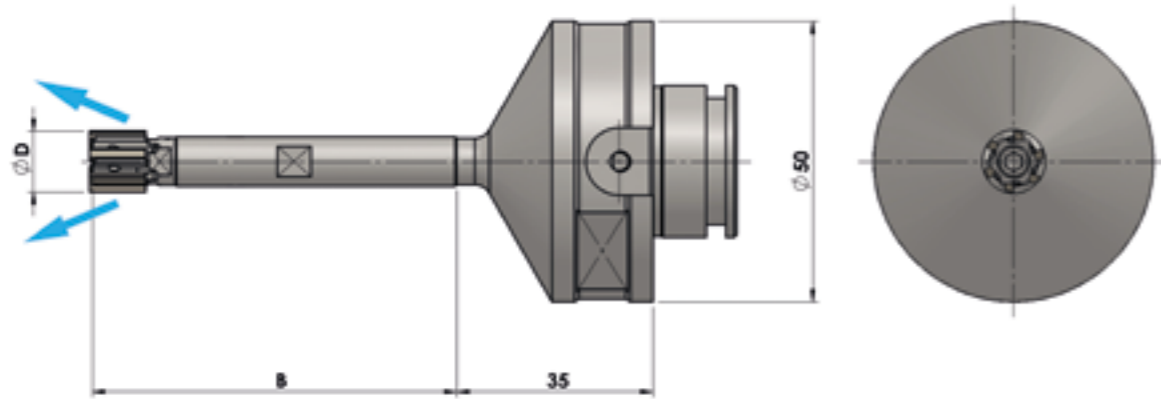

FORI CIECHI

Refrigerazione Assiale

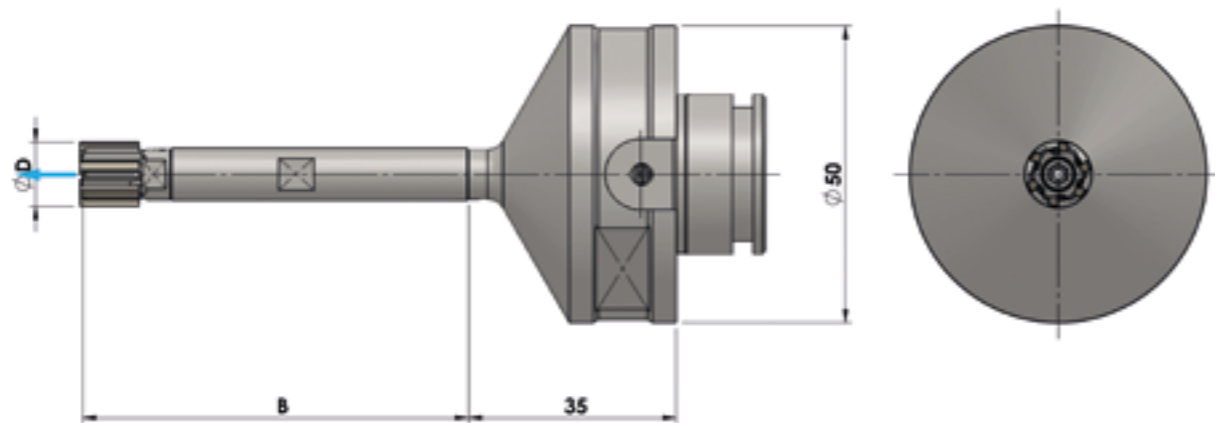

CODICE MANDRINO	ϕD mm	B mm
5000-MM-001	9,60÷11,60	65
5000-MM-002	11,61÷14,60	65
5000-MM-003	14,61÷17,60	80
5000-MM-004	17,61÷21,60	100
5000-MM-005	21,61÷26,60	110
5000-MM-006	26,61÷32,60	120

