



**ALLIED MACHINE
& ENGINEERING**

WOHLHAUPTER®

Holemaking Solutions for Today's Manufacturing



Wohlhaupter® MultiBore® System Tools CATALOGUE



Drilling



Boring



Reaming



Burnishing



Threading



Specials

The MVS Connection

Wohlhaupter® GmbH developed the world's first modular tooling system called MultiBore® in 1973. The modular tooling system was designed to be compatible with all machine spindles, and its connection features a triple point clamp (Figure 1). The triple point clamp (1, 2, & 3) maximizes rigidity and creates an accuracy less than 3µm when the tool is changed.

- Ensures high axial clamping forces on mating surfaces
- Provides maximum rigidity
- Threaded taper pins for precise cutter positioning

Figure 1

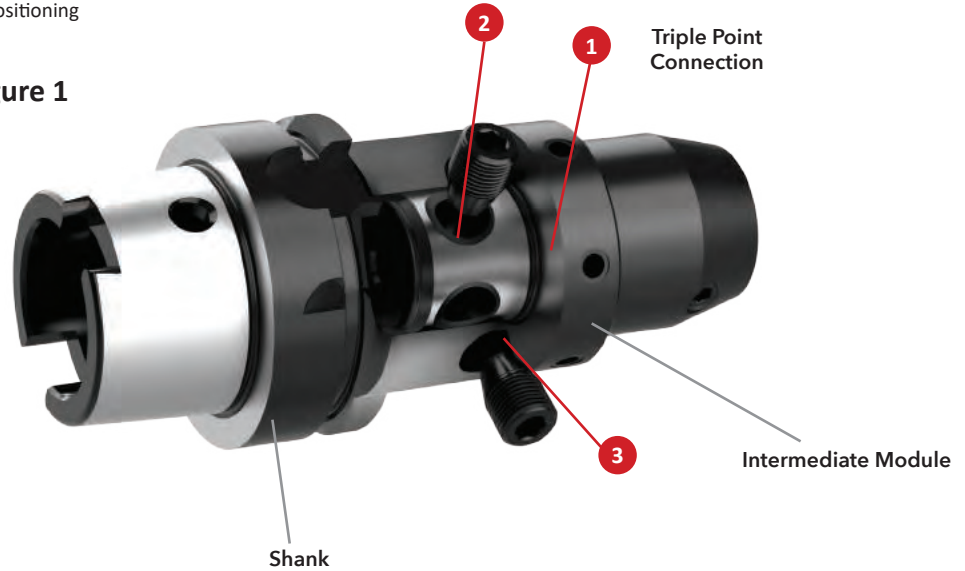

MVS Connection Color Guide

Wohlhaupter® created a unique color-coding system to find the right connections for different tool components quickly and easily. Each Wohlhaupter / MVS connection size has its own color-coding. Simply match the colors to select the correct combination of tool components (Figure 2). We've also incorporated the color-coding system into our packaging to reduce setup time even more.

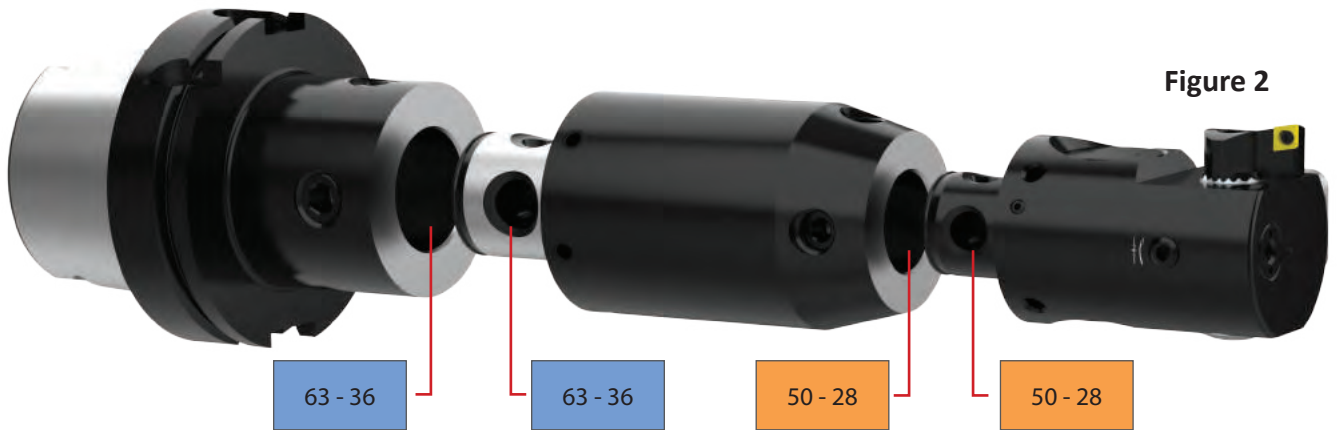

Figure 2

M 8	19.5 - 22	22 - 11	25 - 14	32 - 18	40 - 22	50 - 28	63 - 36	80 - 36	100 - 56	D 40	D 60
-----	-----------	---------	---------	---------	---------	---------	---------	---------	----------	------	------

MVS Connection Example - Selecting the Correct Intermediate Module

Example Machining Parameters

Hole Diameter: 75.00mm (2.942")
 Hole Depth: 200.00mm (7.874")
 Machine Spindle: HSK-A 100 DIN 69893

1 Select your boring tool

- Example: 464 Balanced Boring Head

2 Select the tool that meets the required boring range

- MVS connection: **50 - 28**
- A = 65.00mm - 83.00mm (2.559" - 3.268")
- Part No. : **464006**



1 **3ETECH Digital Balanced 465 (464) Boring Head**

2

D ₂ D ₁	A	X ₁	Order	Boring Head
50 - 28	65.00 - 83.00	75.00	3	464006
50 - 28	65.00 - 83.00	75.00	3	464006
50 - 28	65.00 - 83.00	75.00	3	464006
63 - 36	82.00 - 103.00	90.00	3	464007
63 - 36	82.00 - 103.00	90.00	3	464007
63 - 36	82.00 - 103.00	90.00	3	464007
80 - 36	100.00 - 130.00	90.00	3	464008
80 - 36	100.00 - 130.00	90.00	3	464008
80 - 36	100.00 - 130.00	90.00	3	464008
80 - 36	125.00 - 167.50	90.00	3	464009
80 - 36	125.00 - 167.50	90.00	3	464009

3 Select the master shank that fits your spindle

- Machine spindle: DIN 69893 HSK

4 Choose the connection that fits your application

- MVS connection: **63 - 36**
- Part No. : **245015**

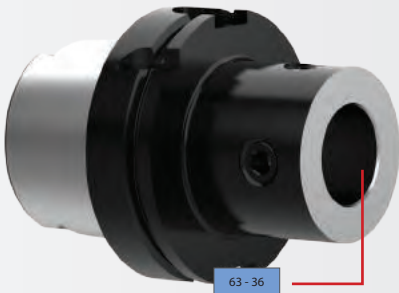

3 **HSK Master Shanks (DIN 69893)**

4

D ₂	D ₁	L ₁	Order	Part No.
63	36	51.00	g)	245015
63	36	ER 40	g)	252090*
100	50	50 - 28	g)	245014
100	50	50 - 28	g)	246020
100	50	50 - 28	g)	246021
100	63	63 - 36	g)	245015
100	63	63 - 36	g)	246019
100	63	63 - 36	g)	246022
100	80	80 - 36	g)	245016
100	80	80 - 36	g)	246018
100	80	80 - 36	g)	246023

5 Select the correct intermediate module

Must meet the hole depth requirements and MVS connections for both the boring head and shank

Hole depth: 200.00mm (7.874")
 Boring tool 464006 length (X₁): 75.00mm (2.953")
 Master shank 245015 length (L₁): 51.00mm (2.008")
 Minimum required length of adapter: 74.00mm (2.913")
 Boring tool 464006 MVS connection: **50 - 28**
 Master shank 245015 MVS connection: **63 - 36**
 Adapter Part No.: **119025**



5

D ₂ D ₁	L ₁	Order	Part No.
63 - 36	51 - 18	g)	219088
63 - 36	51 - 18	g)	219089
63 - 36	51 - 18	g)	219021
63 - 36	51 - 18	g)	219033*
63 - 36	51 - 18	g)	219091
63 - 36	51 - 18	g)	219092
63 - 36	51 - 18	g)	219067
63 - 36	51 - 18	g)	119064
63 - 36	51 - 18	g)	119025**
63 - 36	51 - 18	g)	119026**
63 - 36	51 - 18	g)	119098
63 - 36	51 - 18	g)	219066

SECTION

B10-A

Versatile Fine Boring

Wohlhaupter® Versatile Fine Boring

VarioBore | 248 | PrimeBore | Digital 510 | DigiBore

► Diameter Range: 0.40 mm - 208.00 mm



WOHLHAUPTER®

Precision boring at its finest.

From high precision to high production, Wohlhaupter has the right solution for your hole finishing applications. With the most reliable digital readout displays, the Wohlhaupter versatile boring product line offers the most precise and flexible modular system on the market.

Your safety and the safety of others is very important. This catalogue contains important safety messages. Always read and follow all safety precautions.



This triangle is a safety hazard symbol. It alerts you to potential safety hazards that can cause tool failure and serious injury.

When you see this symbol in the catalogue, look for a related safety message that may be near this triangle or referred to in the nearby text.

There are safety signal words also used in the catalogue. Safety messages follow these words.

WARNING

WARNING (shown above) means that failure to follow the precautions in this message could result in tool failure and serious injury.

NOTICE means that failure to follow the precautions in this message could result in damage to the tool or machine but not result in personal injury.

NOTE and **IMPORTANT** are also used. These are important that you read and follow but are not safety-related.

Visit www.alliedmachine.com for the most up-to-date information and procedures.

Applicable Industries



Aerospace



Agriculture



Automotive



Firearms



General Machining



Oil & Gas



Renewable Energy

Reference Icons

The following icons will appear throughout the catalogue to help you navigate between products.

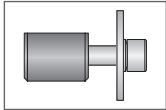

Clamping Elements
For use with insert holders and boring heads

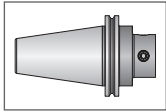

Shanks
A variety of shanks for different machines

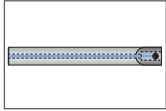

248 Shanks
A variety of shanks for different machines

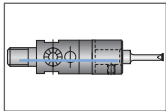

248 Boring Head
248 boring head that connects into the adapter shanks

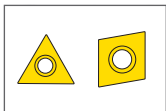

Inserts
For use with insert holder boring heads and boring bars using indexable inserts

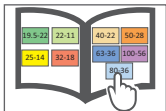

MVS Connection Colour Guide
Detailed instructions and information regarding the MVS connection(s)

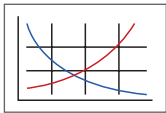

Recommended Cutting Data
Speed and feed recommendations for optimum and safe boring



Through Coolant Option
Indicates that the product is through coolant

Series	Diameter Range
	Metric (mm)
VarioBore 536	0.40 - 152.00
248 Boring Head	3.00 - 30.20
PrimeBore 450	3.00 - 208.00
Digital 510	0.40 - 12.00
DigiBore 501	3.00 - 208.00

Versatile Fine Boring Contents

VarioBore

Product Overview 2 - 3

Boring Heads 4 - 5

Boring Bars 6 - 10

Serrated Tool Bodies | Insert Holders 11 - 12

Serrated Slides | Insert Holders 13

Insert Holders for Boring Heads 14

Outside Turning Serrated Slides | Insert Holders 15 - 16

Reducing Sleeves 17

Accessories 18 - 19

VarioBore Kits 20- 27

248

Product Overview 28 - 29

Boring Heads 30

Boring Bars 31 - 32

Adapters 33

Shanks 34

Accessories 35

PrimeBore

Product Overview 36 - 37

Boring Heads 38

Boring Bars 39 - 40

Serrated Tool Bodies | Insert Holders 42

Serrated Slides | Insert Holders 43 - 44

Outside Turning Insert Holders for Boring Heads 45 - 46

Accessories 47

PrimeBore Kits 48 - 49

Digital 510

Product Overview 50 - 51

Boring Heads | Reducing Sleeves 52

Boring Bars 53 - 56

Serrated Tool Bodies | Insert Holders 57

Accessories 58

DigiBore

Product Overview 60 - 61

Boring Heads 62

Boring Bars 63 - 65

Serrated Tool Bodies | Insert Holders 66 - 67

Serrated Slides | Insert Holders 68

Outside Turning Tools 69 - 70

Accessories 71 - 72

DigiBore Kits 73 - 80

VarioBore Product Overview



VarioBore with **3E^{TECH+}** VERSATILE FINE BORING

Need more versatility?

The Wohlhaupter® VarioBore head offers precision and versatility, and the 3E^{TECH+} docking port provides convenient and simple diameter adjustments.

Experience *precision boring* for yourself.

- Diameter range: 0.40 mm - 152.00 mm
- Offers outside turning capabilities: 2.00 mm - 66.00 mm
- Ease the stress of working on different day-to-day projects with boring kits
- 3E^{TECH+} module provides a simple digital readout
- Max spindle speed: 27,500 RPM



NOTE: 3E^{TECH+} adjustment accuracy of 0.001 mm on diameter

NOTE: Vernier adjustment accuracy of 0.002 mm on diameter

IMPORTANT: Max spindle speed refers to maximum possible speed for an individual boring head and is not a recommended parameter. Refer to page B10-M: 12 for recommended application-specific parameters. Factory technical assistance is available for your specific applications through our Application Engineering department.
email: engineering.eu@alliedmachine.com



3E TECH+
Universal Digital
Module



VarioBore Head

VARIO BORE

with **3E TECH+** Universal Digital
Readout Module

NOTE: 3E TECH+ adjustment accuracy of 0.001 mm on diameter

NOTE: Vernier adjustment accuracy of 0.002 mm on diameter

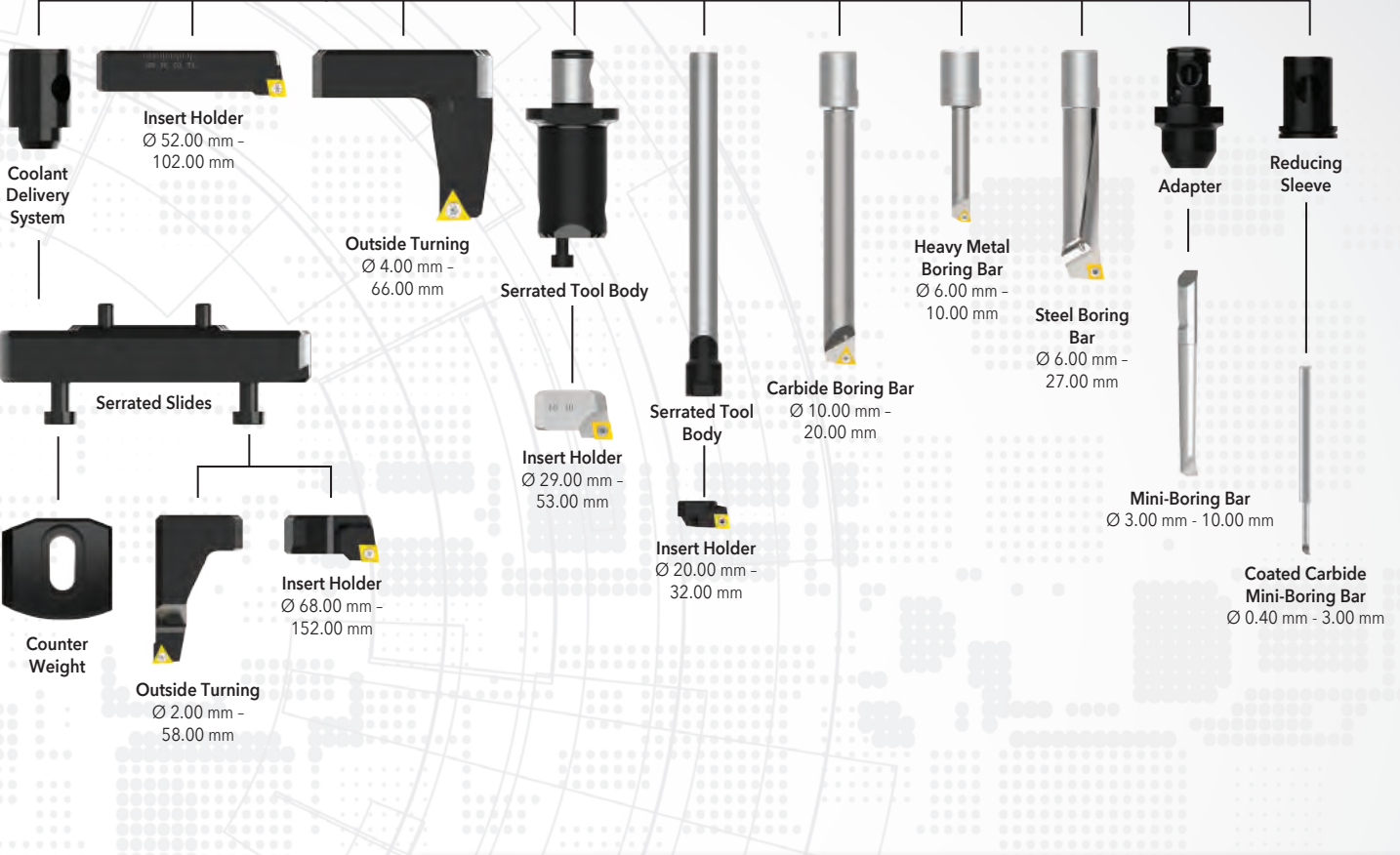

OPERATION **VERSATILITY**

from **0.40 mm** to **152.00 mm**
plus outside turning



NOTE: 3E TECH+ adjustment accuracy of 0.001 mm on diameter

NOTE: Vernier adjustment accuracy of 0.002 mm on diameter



Digital 3E^{TECH+} Boring Head

Diameter Range: 0.40 mm - 152.00 mm

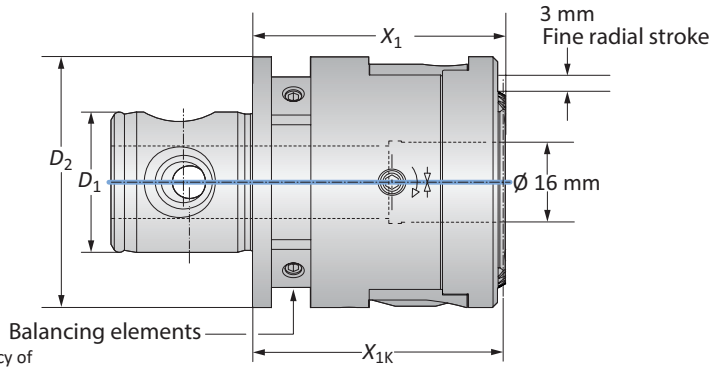

NOTE: Vernier adjustment accuracy of 0.002 mm on diameter

VarioBore Digital 3E^{TECH+} Boring Head

MVS Connection	Boring Head		Weight	Part No.
$D_2 D_1$	Boring Range	X_1	X_{1K}	
50 - 28	0.40 - 152.00	50.00	49.50	536002

NOTE: Balancing elements, 3E^{TECH+} digital readout module, and charging unit must be ordered separately.

NOTE: VarioBore heads are compatible with Kaiser® connection

3E^{TECH+} Digital Readout Module

Part No.	Charging Unit*
536015	536016

NOTE: WEEE-Reg.-Nr. DE 15820388

*Charging unit sold separately



NOTE: 3E^{TECH+} adjustment accuracy of 0.001 mm on diameter

Key on B10-A:1

B10-M: 12-13

B10-F

B10: VI-VII

Ⓜ = Metric (mm)

IMPORTANT: Max spindle speed refers to maximum possible speed for an individual boring head and is not a recommended parameter. Refer to page B10-M: 12 for recommended application-specific parameters. Factory technical assistance is available for your specific applications through our Application Engineering department.
 email: engineering.eu@alliedmachine.com

Non-Digital Boring Head

Diameter Range: 0.40 mm - 152.00 mm

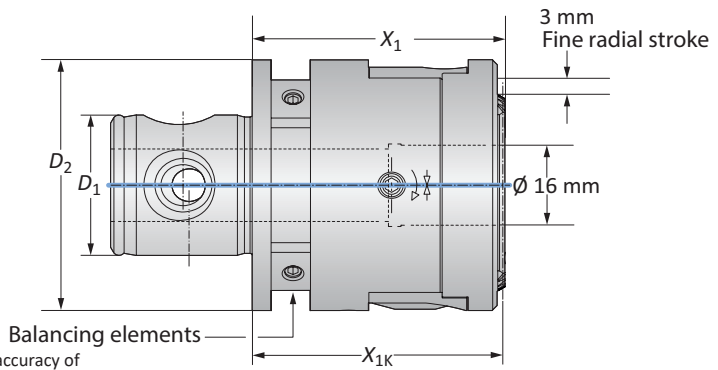

NOTE: Vernier adjustment accuracy of 0.002 mm on diameter

VarioBore Non-Digital Boring Head

MVS Connection		Boring Head			Weight	Part No.
$D_2 D_1$	Boring Range	X_1	X_{1K}			
 50 - 28	0.40 - 152.00	50.00	49.50	0.70 (kg)	536001	

NOTE: Balancing elements must be ordered separately.

NOTE: VarioBore heads are compatible with Kaiser® connection

Key on B10-A-1

B10-M: 12-13

B10-F

B10: VI-VII

 = Metric (mm)

IMPORTANT: Max spindle speed refers to maximum possible speed for an individual boring head and is not a recommended parameter. Refer to page B10-M: 12 for recommended application-specific parameters. Factory technical assistance is available for your specific applications through our Application Engineering department.
 email: engineering.eu@alliedmachine.com

Mini Boring Bars

WHC126 Coated Carbide | Diameter Range: 0.40 mm - 3.00 mm

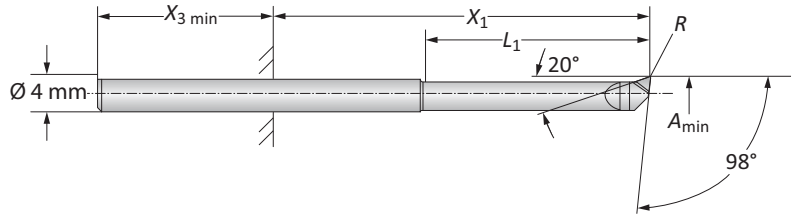

Mini Boring Bars

	Boring Range		Boring Bar*			Part No.
	A_{min}	X_1	$X_{3 min}$	L_1	R	
m	0.40	3.00 - 17.00	25.00	2.00	0.03	081401WHC126
	0.60	4.00 - 18.00	25.00	3.00	0.04	081402WHC126
	0.80	5.00 - 19.00	25.00	4.00	0.04	081403WHC126
	1.00	6.00 - 20.00	25.00	5.00	0.05	081404WHC126
	1.50	8.50 - 22.50	25.00	7.50	0.05	081405WHC126
	2.00	11.00 - 25.00	25.00	10.00	0.05	081406WHC126
	2.50	13.50 - 27.50	25.00	12.50	0.05	081407WHC126
	2.80	15.00 - 28.00	25.00	14.00	0.07	081408WHC126

*Fixture-through reducing sleeve (B10-A: 17)

B10-M: 12-13

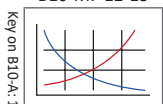

B10: VI-VII



m = Metric (mm)

Mini Boring Bars

WHC05 | WHW04 | WBN150 | Diameter Range: 3.00 mm - 10.00 mm

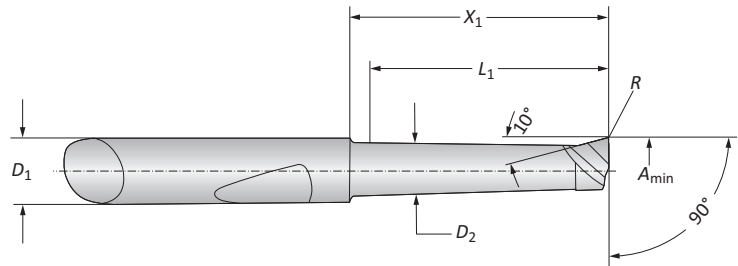

Mini Boring Bars

Boring Range	Boring Bar					Part No.		
	A_{min}	D_1	D_2	X_1	L_1	R	Coated Carbide	Uncoated Carbide
3.00	6.00	2.60	11.50	10.00	0.10	081306WHC05	–	081322WBN150
3.00	6.00	2.60	16.50	15.00	0.10	081307WHC05	081307WHW04	–
4.00	6.00	3.60	12.00	10.00	0.20	081308WHC05	–	081317WBN150
4.00	6.00	3.60	17.00	15.00	0.20	081309WHC05	–	081341WBN150
4.00	6.00	3.60	22.00	20.00	0.20	081310WHC05	081310WHW04	–
5.00	6.00	4.60	12.00	10.00	0.20	081311WHC05	–	081318WBN150
5.00	6.00	4.60	22.00	20.00	0.20	081312WHC05	–	081319WBN150
5.00	6.00	4.60	32.00	30.00	0.20	081313WHC05	081313WHW04	–
6.00	6.00	5.60	22.00	20.00	0.20	081314WHC05	–	081320WBN150
6.00	6.00	5.60	32.00	30.00	0.20	081315WHC05	–	081321WBN150
6.00	6.00	5.60	42.00	40.00	0.20	081316WHC05	081316WHW04	–
8.00	8.00	7.60	25.00	23.00	0.20	081323WHC05	–	–
8.00	8.00	7.60	50.00	48.00	0.20	081324WHC05	–	–



Adapters

Boring Range	Adapter				Part No.
	A_{min}	D_3	D_5	X_1	
3.00	6.00	20.00	22.50	14.00	319010
8.00	8.00	22.00	22.50	14.00	236071

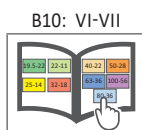
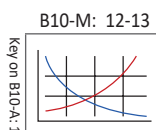
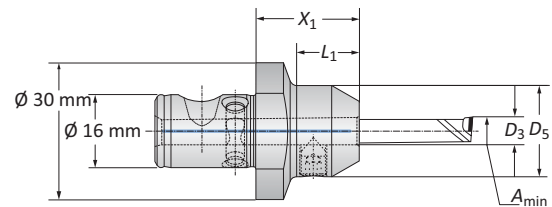

m = Metric (mm)

Boring Bars

Steel | Diameter Range: 6.00 mm - 27.00 mm



Form 101

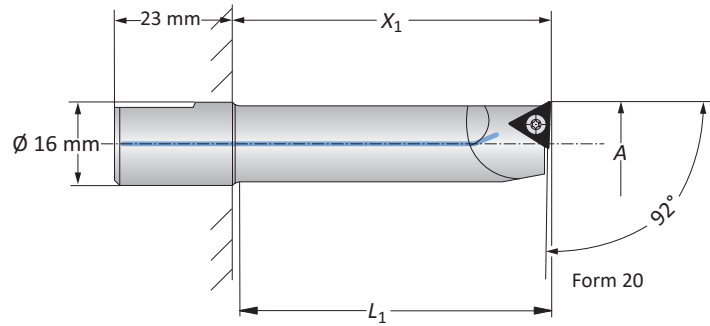

Boring Range	Boring Bar		Weight	Insert Form	Part No.	Insert Form	Part No.	
	A	X ₁						L ₁
6.00 - 8.00		22.00	19.00	0.03 (kg)	-	-	211*	081053
8.00 - 10.00		30.00	27.00	0.04 (kg)	-	-	211*	218071
10.00 - 12.00		45.00	42.00	0.05 (kg)	-	-	20*	081044
10.00 - 12.00		25.00	22.00	0.04 (kg)	101	218047	20*	218058
10.00 - 12.00		35.00	32.00	0.05 (kg)	101	218048	20*	218059
12.00 - 14.00		30.00	27.00	0.05 (kg)	101	218012	20*	218014
12.00 - 14.00		45.00	42.00	0.06 (kg)	101	218049	20*	218060
14.00 - 16.00		35.00	32.00	0.06 (kg)	101	218050	20*	218061
m 14.00 - 16.00		50.00	47.00	0.08 (kg)	101	218051	20*	218062
15.00 - 17.00		37.00	34.00	0.06 (kg)	-	-	20*	081048
15.00 - 17.00		60.00	57.00	0.08 (kg)	101	081041	20*	081045
16.00 - 20.00		40.00	37.00	0.08 (kg)	101	218052	20*	218063
16.00 - 20.00		60.00	57.00	0.09 (kg)	101	218053	20*	218064
20.00 - 25.00		37.00	34.00	0.07 (kg)	-	-	20*	081049
20.00 - 25.00		70.00	67.00	0.11 (kg)	101	081042	20*	081046
25.00 - 27.00		37.00	34.00	0.07 (kg)	-	-	20*	081050
25.00 - 27.00		70.00	67.00	0.11 (kg)	101	081043	20*	081047

*Not suitable for indexable inserts with a radius of 0.80 mm

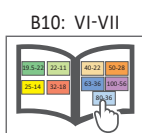
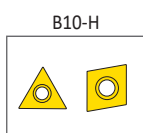
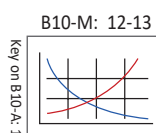

Boring Bars

Heavy Metal | Carbide Diameter Range: 6.00 mm - 20.00 mm

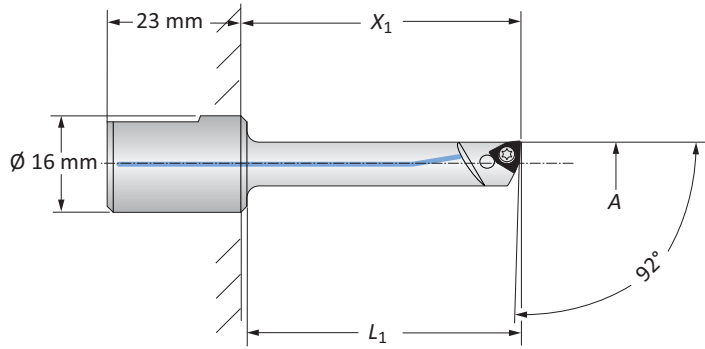

Heavy Metal Boring Bars | Diameter Range: 6.00 mm - 10.00 mm

m	Boring Range		Boring Bar		Weight	Insert Form	Part No.
	A	X ₁	L ₁				
	6.00 - 8.00	32.00	29.00		0.08 (kg)	211*	081055
	8.00 - 10.00	45.00	42.00		0.09 (kg)	211*	218072

*Not suitable for indexable inserts with a radius of 0.80 mm



Form 101

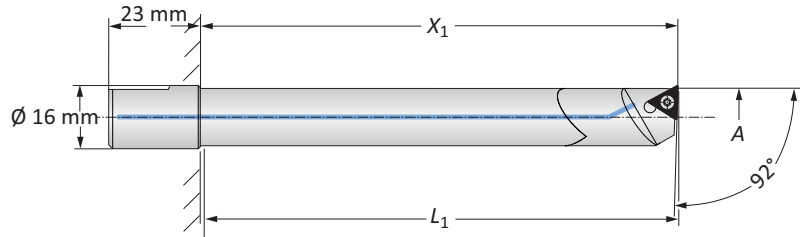

Form 20

Carbide Boring Bars | Diameter Range: 10.00 mm - 20.00 mm

m	Boring Range		Boring Bar		Weight	Insert Form	Part No.	Insert Form	Part No.
	A	X ₁	L ₁						
	10.00 - 12.00	55.00	52.00		0.07 (kg)	101	218042	20*	218037
	10.00 - 12.00	75.00	72.00		0.09 (kg)	101	218032	20*	218029
	12.00 - 14.00	70.00	67.00		0.10 (kg)	101	218043	20*	218038
	12.00 - 14.00	90.00	87.00		0.15 (kg)	101	218033	20*	218030
	14.00 - 16.00	75.00	72.00		0.16 (kg)	101	218044	20*	218039
	14.00 - 16.00	100.00	97.00		0.20 (kg)	101	218045	20*	218040
	16.00 - 20.00	90.00	87.00		0.26 (kg)	101	218046	20*	218041
	16.00 - 20.00	120.00	117.00		0.33 (kg)	101	218034	20*	218031

*Not suitable for indexable inserts with a radius of 0.80 mm

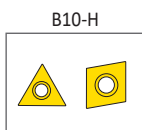
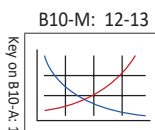

m = Metric (mm)
Inserts sold separately

Boring Bars

Steel | Carbide | Diameter Range: 6.00 mm - 20.00 mm

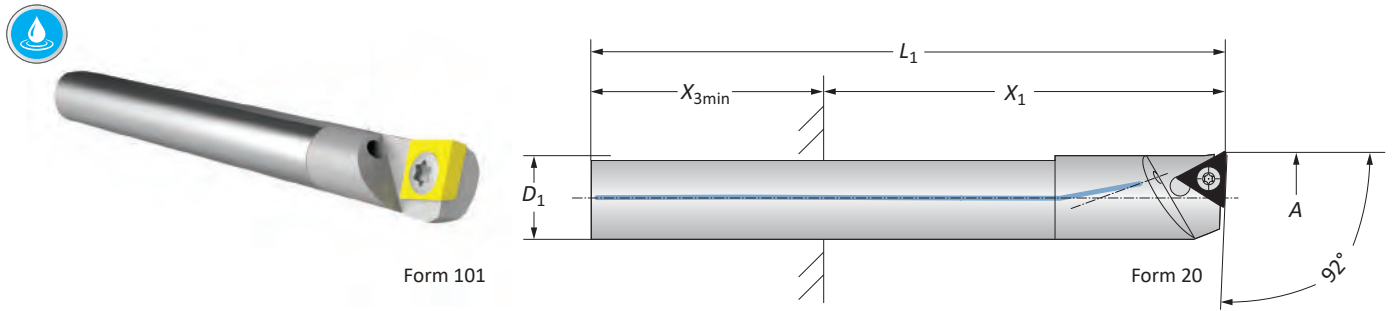

Steel Boring Bars | Diameter Range: 6.00 mm - 20.00 mm

Boring Range	Boring Bar					Weight	Part No.			
	A	D ₁	X ₁	X _{3 min}	L ₁		Insert Form	Boring Bar	Insert Form	Boring Bar
6.00 - 8.00	5.00*	12.50 - 25.00	25.00	70.00	0.01 (kg)	211**	514032	-	-	
8.00 - 10.00	7.00*	17.50 - 35.00	25.00	81.00	0.02 (kg)	211**	514033	-	-	
10.00 - 12.00	8.00*	20.00 - 40.00	25.00	85.00	0.03 (kg)	101	514003	20**	514004	
12.00 - 14.00	10.00*	25.00 - 50.00	25.00	100.00	0.05 (kg)	101	514005	20**	514006	
14.00 - 16.00	12.00*	30.00 - 60.00	30.00	114.00	0.09 (kg)	101	514007	20**	514008	
16.00 - 18.00	14.00*	56.00 - 70.00	30.00	121.00	0.13 (kg)	101	514009	20**	514010	
18.00 - 20.00	14.00*	56.00 - 70.00	30.00	121.00	0.13 (kg)	101	514011	20**	514012	

*Fixture-through reducing sleeve required (B10-A: 17)

**Not suitable for indexable inserts with a radius of 0.8 mm

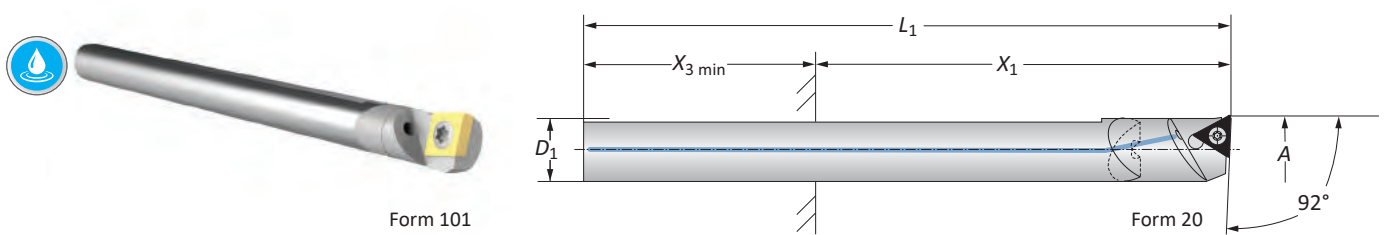

Carbide Boring Bars | Diameter Range: 6.00 mm - 20.00 mm

Boring Range	Boring Bar					Weight	Part No.			
	A	D ₁	X ₁	X _{3 min}	L ₁		Insert Form	Boring Bar	Insert Form	Boring Bar
6.00 - 8.00	5.00*	12.50 - 40.00	25.00	90.00	0.02 (kg)	211**	514034	-	-	
8.00 - 10.00	7.00*	21.00 - 56.00	25.00	109.00	0.05 (kg)	211**	514035	-	-	
10.00 - 12.00	8.00*	22.00 - 64.00	25.00	117.00	0.07 (kg)	101	514015	20**	514016	
12.00 - 14.00	10.00*	51.00 - 80.00	25.00	140.00	0.13 (kg)	101	514017	20**	514018	
14.00 - 16.00	12.00*	68.00 - 96.00	30.00	162.00	0.22 (kg)	101	514019	20**	514020	
16.00 - 18.00	14.00*	77.00 - 112.00	30.00	142.00	0.26 (kg)	101	514021	20**	514022	
16.00 - 18.00	14.00*	112.00 - 147.00	30.00	177.00	0.33 (kg)	101	514023	20**	514024	
18.00 - 20.00	14.00*	77.00 - 112.00	30.00	142.00	0.26 (kg)	101	514025	20**	514026	
18.00 - 20.00	14.00*	112.00 - 147.00	30.00	177.00	0.33 (kg)	101	514027	20**	514028	

*Fixture-through reducing sleeve required (B10-A: 17)

**Not suitable for indexable inserts with a radius of 0.80 mm

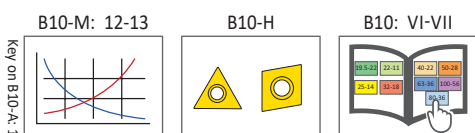

m = Metric (mm)
Inserts sold separately

Serrated Tool Bodies | Insert Holders

Diameter Range: 20.00 mm - 32.00 mm

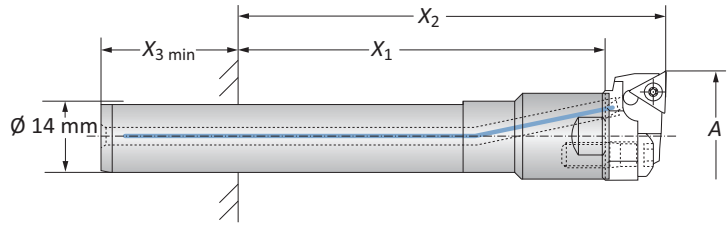

Serrated Tool Bodies

Substrate	Boring Range A	Serrated Tool Body*			Weight	Part No.
		X ₁	X ₂	X _{3 min}		
Steel	20.00 - 32.00	37.00 - 72.00	49.00 - 84.00	30.00	0.13 (kg)	514029
Carbide	20.00 - 32.00	65.00 - 100.00	77.00 - 112.00	30.00	0.25 (kg)	514030
Carbide	20.00 - 32.00	100.00 - 135.00	112.00 - 147.00	30.00	0.33 (kg)	514031

*Fixture-through reducing sleeve (B10-A: 17)

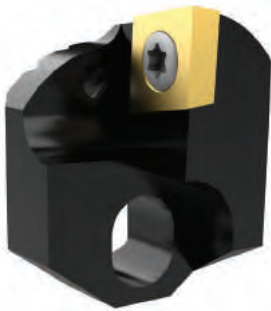

Form 101

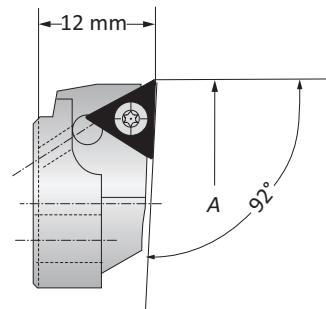

Form 20

Insert Holders

Boring Range A	Weight	Insert Form	Part No.	Insert Form	Part No.
22.00 - 24.00	0.01 (kg)	101	502053	20*	502047
24.00 - 26.00	0.01 (kg)	101	502054	20*	502048
26.00 - 28.00	0.01 (kg)	101	502055	20*	502049
28.00 - 30.00	0.01 (kg)	101	502056	20*	502050
30.00 - 32.00	0.01 (kg)	101	502057	20*	502051

*Not suitable for indexable inserts with a radius of 0.80 mm

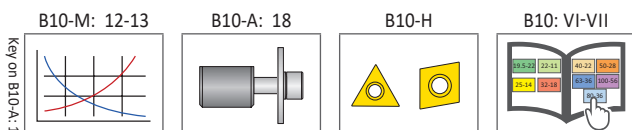

m = Metric (mm)
Inserts sold separately

Serrated Tool Bodies | Insert Holders

Diameter Range: 29.00 mm - 53.00 mm

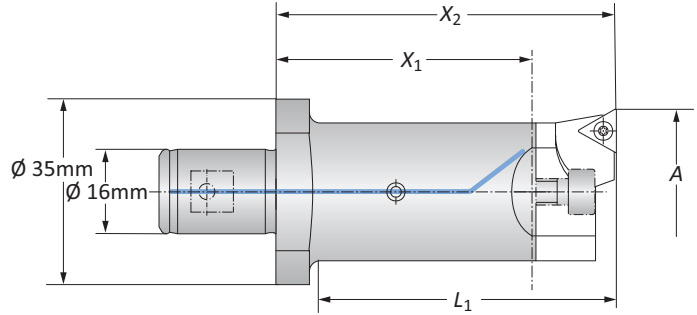

Serrated Tool Bodies

	Boring Range	Serrated Tool Body			Weight	Part No.
	A	X ₁	X ₂	L ₁		
m	29.00 - 53.00	48.00	64.00	56.00	0.20 (kg)	236021
	29.00 - 53.00	84.00	100.00	92.00	0.30 (kg)	236031

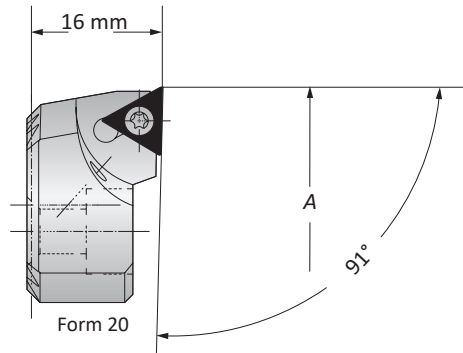

Insert Holders

	Boring Range	Weight	Insert Form	Part No.
	A			
m	29.00 - 41.00	0.04 (kg)	101	236023
	29.00 - 41.00	0.04 (kg)	20*	236022
	40.00 - 53.00	0.06 (kg)	101	236025
	40.00 - 53.00	0.06 (kg)	20*	236024

*Not suitable for indexable inserts with a radius of 0.80 mm

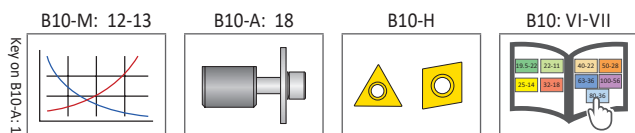

B10-A: 12

www.alliedmachine.com | +44 (0) 1384 400 900 | enquiries.eu@alliedmachine.com

m = Metric (mm)
Inserts sold separately

Alu-Line Serrated Slides | Insert Holders

Diameter Range: 68.00 mm - 152.00 mm

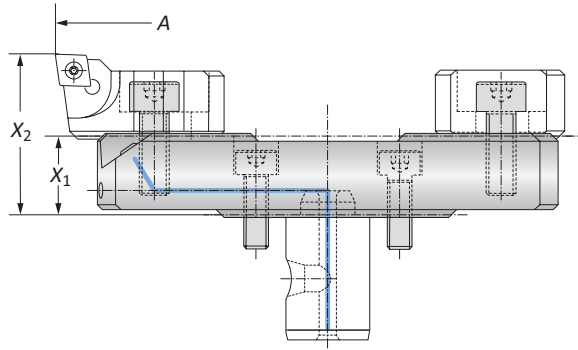

Alu-Line Serrated Slides

	Boring Range		Serrated Slide		Weight	Part No.
	A	X ₁	X ₂			
	68.00 - 96.00	16.00	32.50	0.10 (kg)	501054	
	96.00 - 124.00	16.00	32.50	0.10 (kg)	501055	
	124.00 - 152.00	16.00	32.50	0.20 (kg)	501056	

Insert Holders

	Boring Range		Insert Form	Part No.
	A	Weight		
	68.00 - 152.00	0.05 (kg)	101	502064
	68.00 - 152.00	0.05 (kg)	20	502069



Form 20

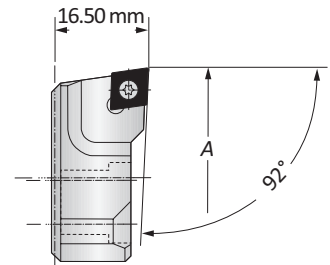

Form 101

Counterweight

	Counterweight		Part No.
	X ₁	Weight	
	13.40	0.05 (kg)	502165

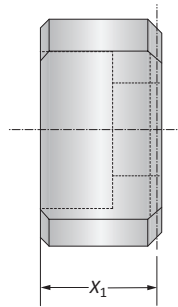

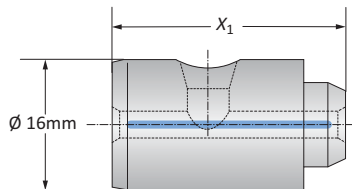

Alu-Line Coolant Delivery Section

	Coolant Delivery		Part No.
	X ₁	Weight	
	25.50	0.01 (kg)	450137

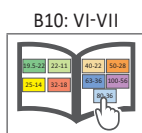
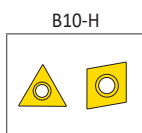
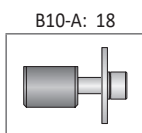

B10-M: 12-13
Key on B10-A-1



 = Metric (mm)
Inserts sold separately

Insert Holders for Boring Heads

Diameter Range: 52.00 mm - 102.00 mm



Form 101

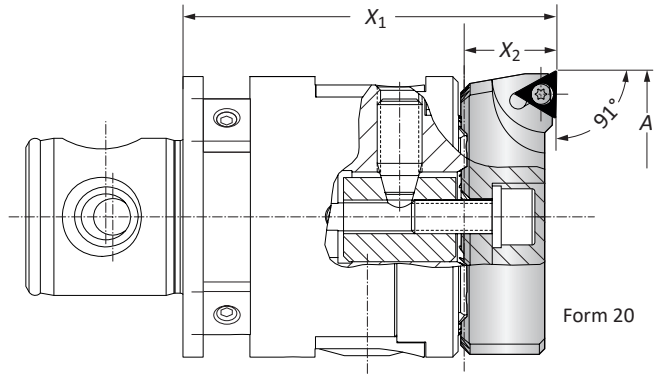

Form 20

Insert Holders for Boring Heads

	Boring Range		Insert Holder		Weight	Insert Form	Part No.
	A		X ₁	X ₂			
Ⓜ	52.00 - 77.00		66.00	16.50	0.06 (kg)	101	236027
	52.00 - 77.00		66.00	16.50	0.06 (kg)	20	236026
	76.00 - 102.00		66.00	16.50	0.10 (kg)	101	236029
	76.00 - 102.00		66.00	16.50	0.10 (kg)	20	236028

Clamping Piece for Insert Holder for Boring Heads

	Boring Range	Service Key	Complete Part No.
Ⓜ	52.00 - 102.00	s5	236020

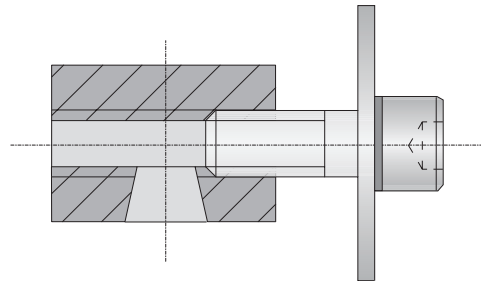

B10-M: 12-13

B10-A: 18

B10-H

B10: VI-VII

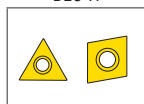
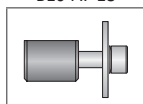
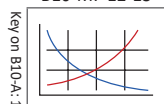

B10-A: 14

www.alliedmachine.com | +44 (0) 1384 400 900 | enquiries.eu@alliedmachine.com

Ⓜ = Metric (mm)
Inserts sold separately

Outside Turning Insert Holders for Boring Heads

Outside Turning | Diameter Range: 4.00 mm - 66.00 mm

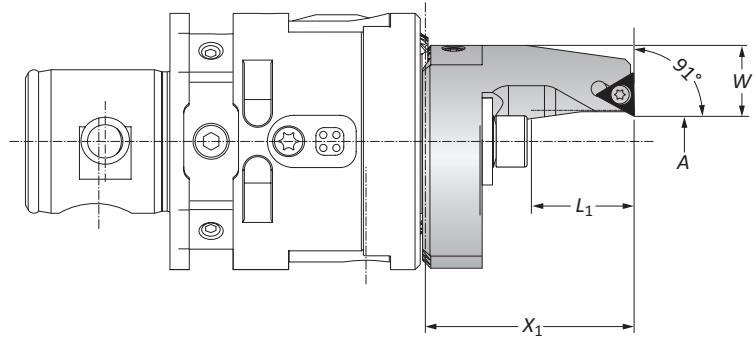

Type A Insert Holders

	Boring Range		Insert Holder			Weight	Type	Insert Form	Part No.
	A	X ₁	L ₁	W					
m	4.00 - 17.50	40.50	20.00	16.60	0.10	A	20*	236081	
	16.50 - 30.00	50.50	30.00	11.10	0.10	A	20*	236082	

NOTE: Clockwise and neutral execution

*Not suitable for indexable inserts with a radius of 0.80 mm

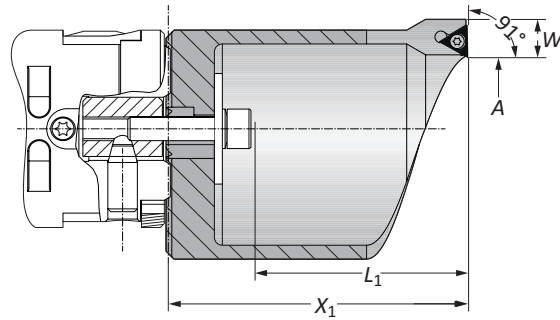
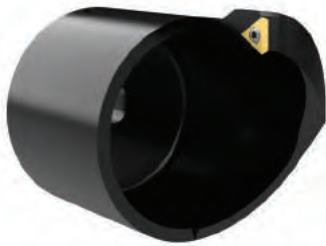

Type B Insert Holders

	Boring Range		Insert Holder			Weight	Type	Insert Form	Part No.
	A	X ₁	L ₁	W					
m	29.00 - 44.00	75.50	54.00	9.60	0.30 (kg)	B	20*	236083	
	43.00 - 66.00	100.50	79.00	9.60	0.40 (kg)	B	20*	236084	

NOTE: Clockwise and neutral execution

*Not suitable for indexable inserts with a radius of 0.80 mm

Clamping Pieces for Outside Turning Insert Holders

Insert Holder Type	Boring Range	Service Key	Complete Part No.
A	4.00 - 30.00	s5	236088
B	29.00 - 66.00	s5	236089

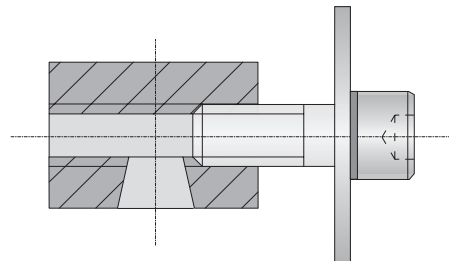

B10-M: 12-13

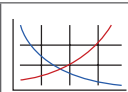

B10-A: 18

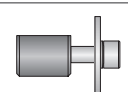

B10-H

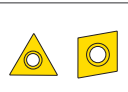

B10: VI-VII

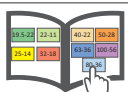

Key on B10-A: 1

m = Metric (mm)
Inserts sold separately

Outside Turning Serrated Slides | Insert Holders

Diameter Range: 2.00 mm - 58.00 mm

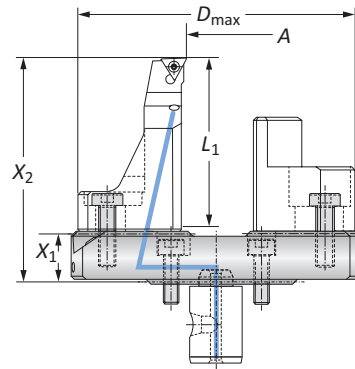

Serrated Slides

	Outside Turning Range	Serrated Slide			Weight	Interfering Diameter	Part No.
	A	X ₁	X ₂	L ₁		D _{max}	
Ⓜ	2.00 - 30.00	16.00	73.00	55.00	0.35 (kg)	101.00	501064
	30.00 - 58.00	16.00	73.00	55.00	0.44 (kg)	129.00	501065



Insert Holder

	Boring Range	Insert Holder	Weight	Insert Form	Part No.
	A	X ₁			
Ⓜ	2.00 - 58.00	57.00	0.15 (kg)	20*	502082

*Clockwise and neutral execution

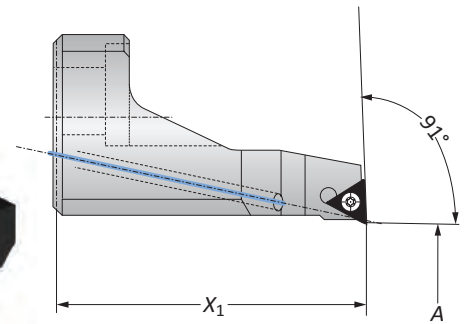

Counterweight

	Counterweight	Weight	Part No.
	X ₁		
Ⓜ	37.75	0.16 (kg)	502183

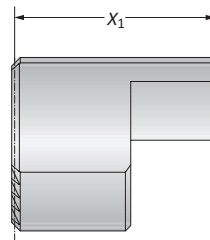

Alu-Line Coolant Delivery Section

	Coolant Delivery Section	Weight	Part No.
	X ₁		
Ⓜ	25.50	0.01 (kg)	450137

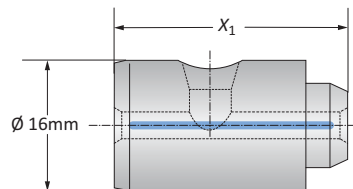

B10-M: 12-13

B10-A: 18

B10-H

B10: VI-VII

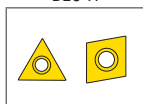
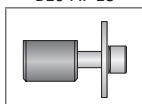
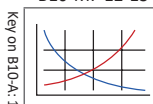

Ⓜ = Metric (mm)
Inserts sold separately

Accessories

Metric Reducing Sleeves

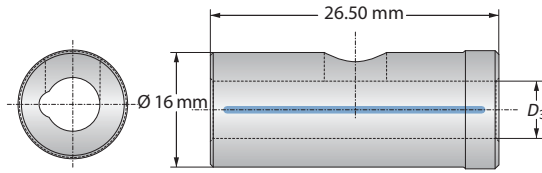

Reducing Sleeves

Reducing Sleeve		Weight	Part No.
	D_3		
m	4.00	0.05 (kg)	450129
	5.00	0.04 (kg)	450130
	7.00	0.04 (kg)	450132
	8.00	0.04 (kg)	450133
	10.00	0.03 (kg)	450134
	12.00	0.02 (kg)	450135
	14.00	0.01 (kg)	450136

 = Metric (mm)

Accessories

Clamping Elements | Thread Pin | Balancing Element | 3E^{TECH} Accessories

Clamping Elements for Insert Holders

Boring Range	1 Cap Screw	Hex Size	2 Washer	3 Clamping Nut	4 Locking Washer	Complete Part No.
4 - 30	070153	s5	315155	236120	215254	236088
29 - 66	070153	s5	315156	236120	215254	236089
52 - 102	115147	s5	115725	236120	-	236020

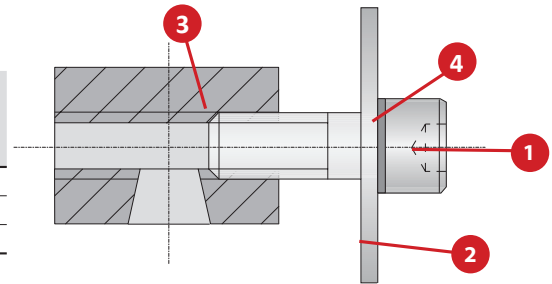

Clamping Elements for Serrated Tool Body

1 Cap Screw	Hex Size	2 Clamping Piece
027154	s4	145184

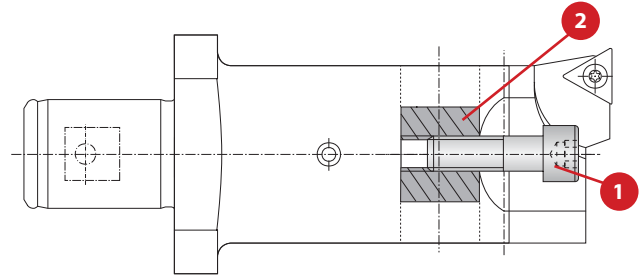

Thread Pin

Service Key	1 Part No.
S3 / A	415244

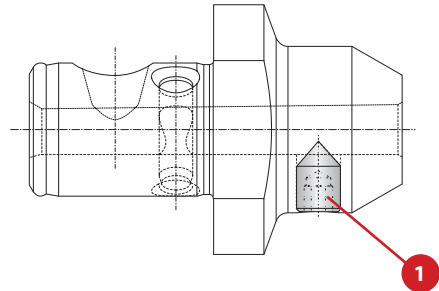

Balancing Element

Nominal Size	Key Size / Type	1 Part No.
M8 x 1.25 x 8	s2 / A	536005

NOTE: Balancing elements sold separately

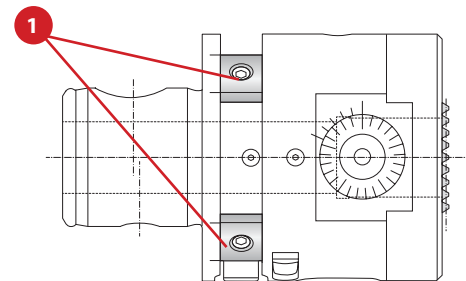

3E^{TECH+} Accessories

1 Charging Unit
Part No.
536016

NOTE: Charging unit sold separately from 3E^{TECH+}



NOTE: 3E^{TECH+} adjustment accuracy of 0.001 mm on diameter

3E^{TECH} Accessories (Old Display)

1 Sealing Ring	2 Battery CR2032
Part No.	Part No.
215483	515491

NOTE: Not required for 3E^{TECH+} (New Display)

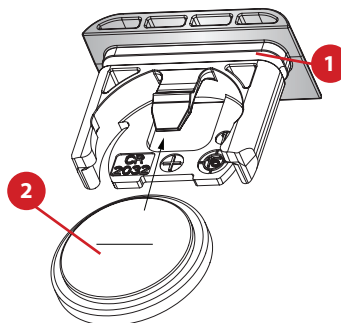

Accessories

No.	Part	Insert Form	Size	Part No.
1	Clamping screw	-	-	070333
2	Thread pin for tool clamping	-	-	215674
3	Clamping screw for balance weight	-	-	115470
4	Balancing screw plug	-	-	115119
5	Insert screws	Form 20 Form 101 Form 211	T7 T8 T6	115535 115676 215377
6	Hex wrench	-	s2.5 s2	115575 215473
7	Hex wrench	-	s4	115576
8	Torx driver	-	T6 T7 T8	115537 115591 115590
9	Torx screwdriver	Form 211 Form 20 Form 101	T6 T7 T8	415507 415508 415514

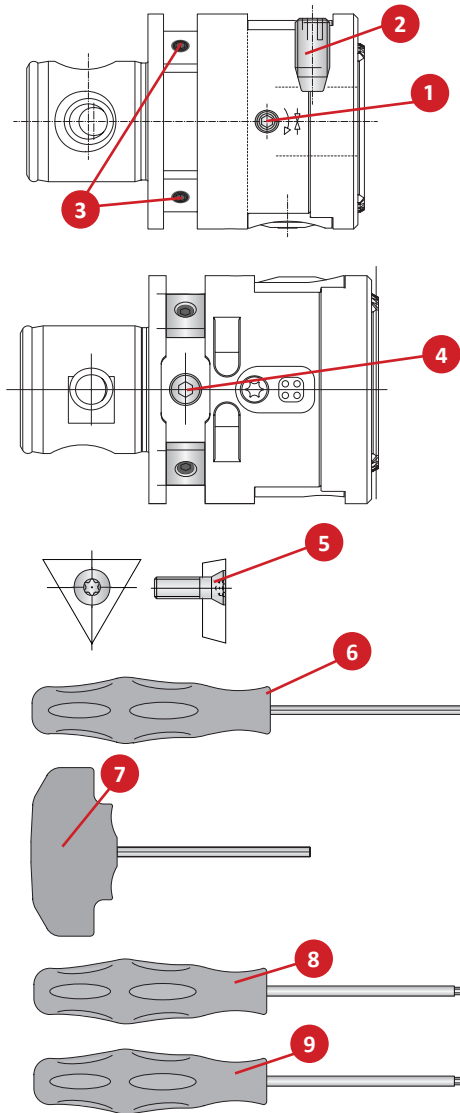

No.	Part	Size	Part No.
1	Screw for securing insert holder	T25	415112
2	Clamping piece	-	145184
3	Cap screw for securing insert holders	s4	027154
4	Cap screw for securing insert holder/counterweight	s4	315248
5	Set screw - coolant	s1.5	114224
6	Cap screw for securing serrated slide	s3	116289
8	Sealing ring for coolant delivery	-	415386

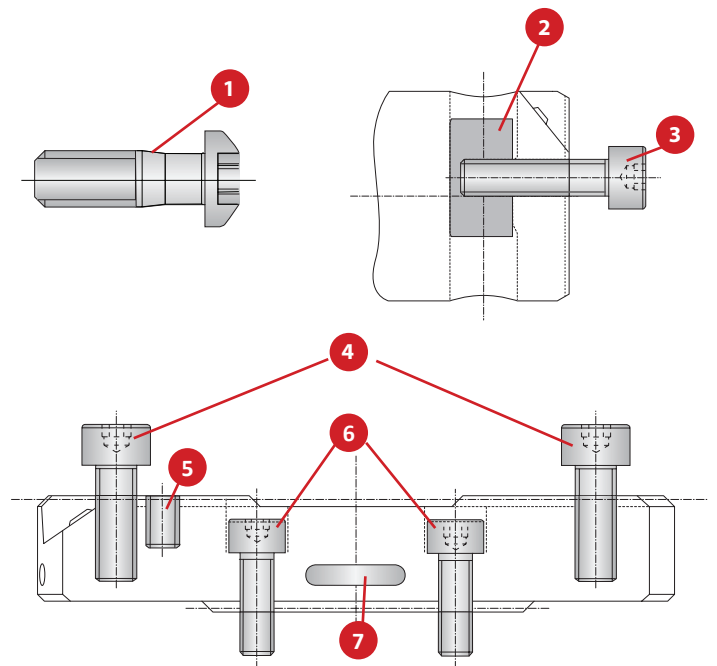

Kit Components

3E^{TECH+} | Insert Form 101 | Diameter Range: 10.00 mm - 30.00 mm

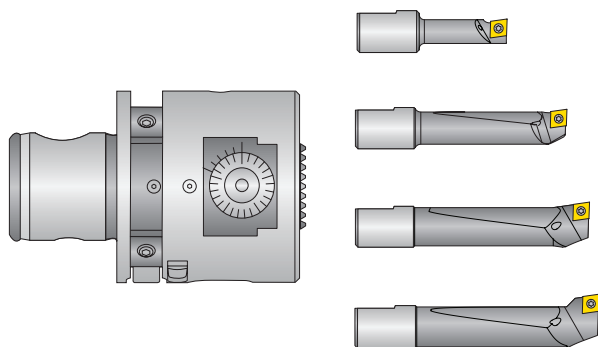

Diameter Range: 10.00 mm - 30.00 mm

Kit Components					
	Boring Head	Boring Bar Range	Boring Bars	Service Keys	Kit No.
m	536002	10.00 - 15.00	218048	115575 (s2.5)	103046
		15.00 - 20.00	081041	215403 (s4)	
		20.00 - 25.00	081042	115590 (T8)	
		25.00 - 30.00	081043		

NOTE: Balancing elements and inserts sold separately

NOTE: 3E^{TECH+} digital readout module and charging station sold separately



3E^{TECH+} Digital Readout Module

Part No.	Charging Unit*
536015	536016

NOTE: WEEE-Reg.-Nr. DE 15820388

*Charging unit sold separately



NOTE: 3E^{TECH+} adjustment accuracy of 0.001 mm on diameter

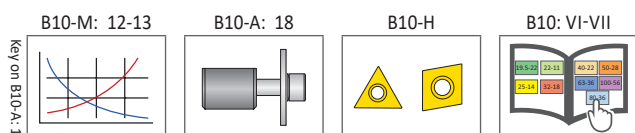

m = Metric (mm)

Inserts sold separately

IMPORTANT: Max spindle speed refers to maximum possible speed for an individual boring head and is not a recommended parameter. Refer to page B10-M: 12 for recommended application-specific parameters. Factory technical assistance is available for your specific applications through our Application Engineering department.
email: engineering.eu@alliedmachine.com

Kit Components

3E^{TECH+} | Insert Form 20 | Diameter Range: 10.00 mm - 30.00 mm

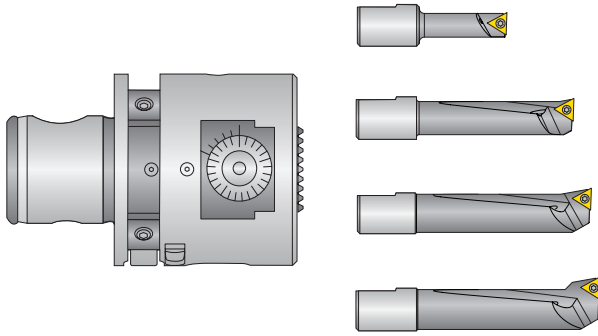

Diameter Range: 10.00 mm - 30.00 mm

Kit Components					
	Boring Head	Boring Bar Range	Boring Bars	Service Keys	Kit No.
m	536002	10.00 - 15.00	218059	115575 (s2.5)	103045
		15.00 - 20.00	081045	215403 (s4)	
		20.00 - 25.00	081046	115591 (T7)	
		25.00 - 30.00	081047		

NOTE: Balancing elements and inserts sold separately

NOTE: 3E^{TECH+} digital readout module and charging station sold separately



3E^{TECH+} Digital Readout Module

Part No.	Charging Unit*
536015	536016

NOTE: WEEE-Reg.-Nr. DE 15820388

*Charging unit sold separately



NOTE: 3E^{TECH+} adjustment accuracy of 0.001 mm on diameter

Key on B10-A-1:

B10-M: 12-13

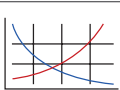

B10-A: 18

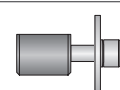

B10-H

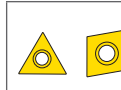

B10: VI-VII



m = Metric (mm)

Inserts sold separately

IMPORTANT: Max spindle speed refers to maximum possible speed for an individual boring head and is not a recommended parameter. Refer to page B10-M: 12 for recommended application-specific parameters. Factory technical assistance is available for your specific applications through our Application Engineering department.
 email: engineering.eu@alliedmachine.com

Kit Components

3ETECH+ | Insert Form 101 | Diameter Range: 10.00 mm - 102.00 mm

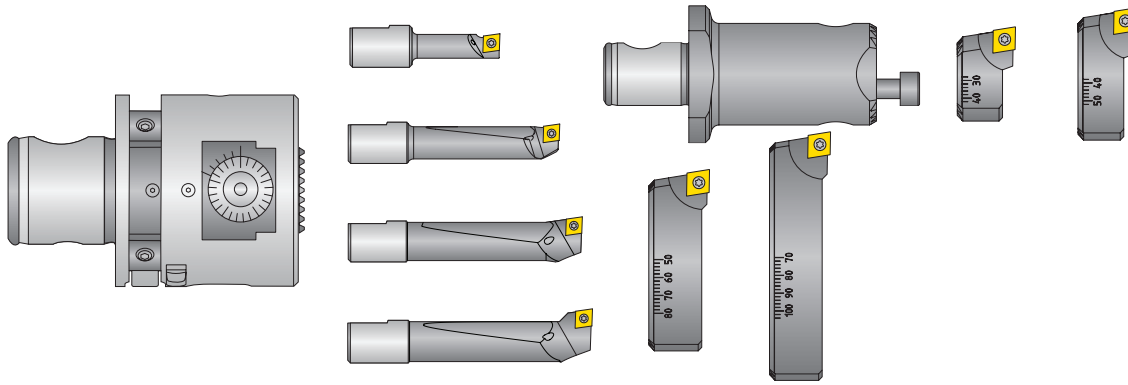

Diameter Range: 10.00 mm - 102.00 mm

Kit Components											
Boring Head	Boring Bars		Serrated Tool Body & Insert Holders			Insert Holders for Boring Head			Clamping Piece	Service Keys	Kit No.
	Boring Bar Range	Part No.	Serrated Tool Body	Insert Holder Range	Part No.	Insert Holder Range	Part No.				
m	10.00 - 15.00	218048	236021	29.00 - 41.00	236023	52.00 - 77.00	236027	236020	115575 (s2.5)	103048	
	15.00 - 20.00	081041		40.00 - 53.00	236025	76.00 - 102.00	236029		215403 (s4)		
	20.00 - 25.00	081042					215521 (s5)				
	25.00 - 30.00	081043					115590 (T8)				

NOTE: Balancing elements and inserts sold separately
 NOTE: 3ETECH+ digital readout module and charging station sold separately



3ETECH+ Digital Readout Module

Part No.	Charging Unit*
536015	536016

NOTE: WEEE-Reg.-Nr. DE 15820388
 *Charging unit sold separately



NOTE: 3ETECH+ adjustment accuracy of 0.001 mm on diameter

Key on B10-A-1

B10-M: 12-13 	B10-A: 18 	B10-H 	B10: VI-VII
------------------	---------------	-----------	-----------------

m = Metric (mm)

Inserts sold separately

IMPORTANT: Max spindle speed refers to maximum possible speed for an individual boring head and is not a recommended parameter. Refer to page B10-M: 12 for recommended application-specific parameters. Factory technical assistance is available for your specific applications through our Application Engineering department.
 email: engineering.eu@alliedmachine.com

Kit Components

3E^{TECH+} | Insert Form 20 | Diameter Range: 10.00 mm - 102.00 mm

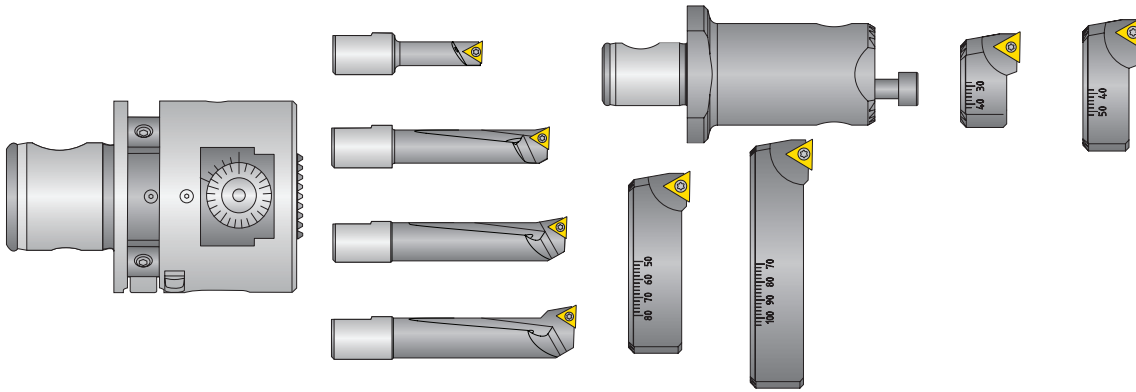

Diameter Range: 10.00 mm - 102.00 mm

Kit Components										
Boring Head	Boring Bars		Serrated Tool Body & Insert Holders			Insert Holders for Boring Head			Service Keys	Kit No.
	Boring Bar Range	Part No.	Serrated Tool Body	Insert Holder Range	Part No.	Insert Holder Range	Part No.	Clamping Piece		
m	10.00 - 15.00	218059	236021	29.00 - 41.00	236026	52.00 - 77.00	236022	236020	115575 (s2.5)	103047
	15.00 - 20.00	081045		40.00 - 53.00	236028	76.00 - 102.00	236024		215403 (s4)	
	20.00 - 25.00	081046					215521 (s5)			
	25.00 - 30.00	081047					115591 (T7)			

NOTE: Balancing elements and inserts sold separately

NOTE: 3E^{TECH+} digital readout module and charging station sold separately



3E^{TECH+} Digital Readout Module

Part No.	Charging Unit*
536015	536016

NOTE: WEEE-Reg.-Nr. DE 15820388

*Charging unit sold separately



NOTE: 3E^{TECH+} adjustment accuracy of 0.001 mm on diameter

Key on B10-A-1

B10-M: 12-13

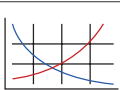

B10-A: 18

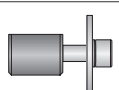

B10-H

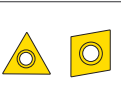

B10: VI-VII

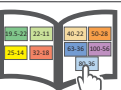

m = Metric (mm)

Inserts sold separately

IMPORTANT: Max spindle speed refers to maximum possible speed for an individual boring head and is not a recommended parameter. Refer to page B10-M: 12 for recommended application-specific parameters. Factory technical assistance is available for your specific applications through our Application Engineering department.
 email: engineering.eu@alliedmachine.com

Kit Components

Non-Digital | Insert Form 101 | Diameter Range: 10.00 mm - 30.00 mm

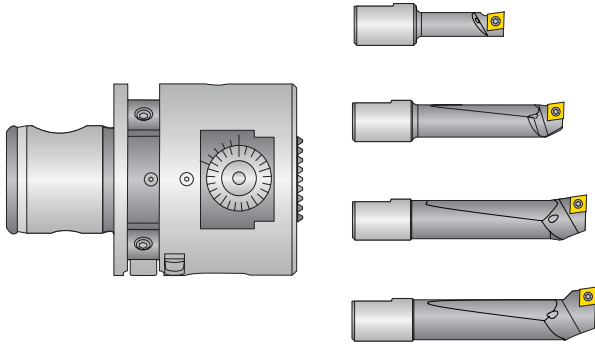

Diameter Range: 10.00 mm - 30.00 mm

Kit Components					
	Boring Head	Boring Bar Range	Boring Bars	Service Keys	Kit No.
m	536001	10.00 - 15.00	218048	115575 (s2.5)	103050
		15.00 - 20.00	081041	215403 (s4)	
		20.00 - 25.00	081042	115590 (T8)	
		25.00 - 30.00	081043		

NOTE: Balancing elements and inserts sold separately



Key on B10-A-1

B10-M: 12-13

B10-A: 18

B10-H

B10: VI-VII

m = Metric (mm)
Inserts sold separately

IMPORTANT: Max spindle speed refers to maximum possible speed for an individual boring head and is not a recommended parameter. Refer to page B10-M: 12 for recommended application-specific parameters. Factory technical assistance is available for your specific applications through our Application Engineering department.
email: engineering.eu@alliedmachine.com

Kit Components

Non-Digital | Insert Form 20 | Diameter Range: 10.00 mm - 30.00 mm

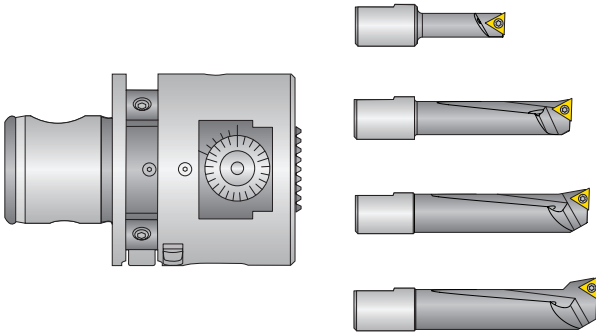

Diameter Range: 10.00 mm - 30.00 mm

Kit Components					
	Boring Head	Boring Bar Range	Boring Bars	Service Keys	Kit No.
m	536001	10.00 - 15.00	218059	115575 (s2.5)	103049
		15.00 - 20.00	081045	215403 (s4)	
		20.00 - 25.00	081046	115591 (T7)	
		25.00 - 30.00	081047		

NOTE: Balancing elements and inserts sold separately



B10-M: 12-13

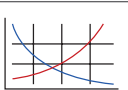

Key on B10-A: 1

B10-A: 18

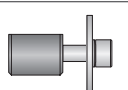

B10-H

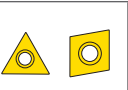

B10: VI-VII

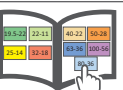

m = Metric (mm)
Inserts sold separately

IMPORTANT: Max spindle speed refers to maximum possible speed for an individual boring head and is not a recommended parameter. Refer to page B10-M: 12 for recommended application-specific parameters. Factory technical assistance is available for your specific applications through our Application Engineering department.
email: engineering.eu@alliedmachine.com

Kit Components

Non-Digital | Insert Form 101 | Diameter Range: 10.00 mm - 102.00 mm

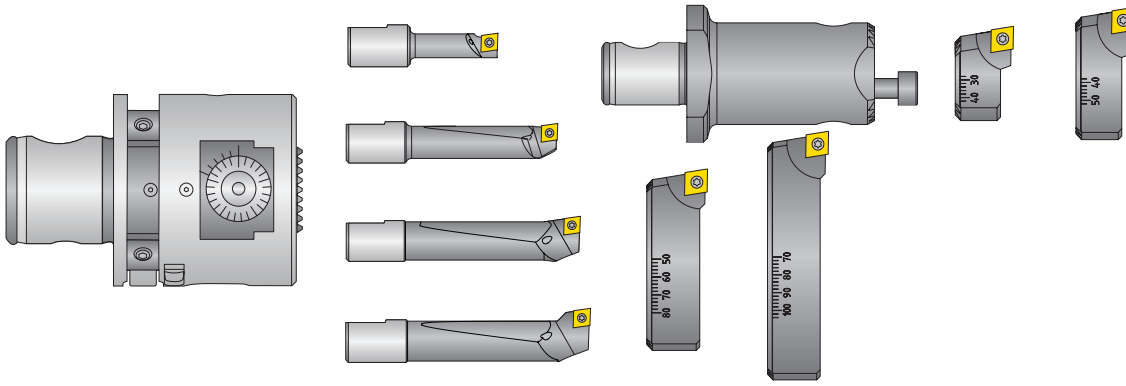

Diameter Range: 10.00 mm - 102.00 mm

Kit Components										
Boring Head	Boring Bars		Serrated Tool Body & Insert Holders			Insert Holders for Boring Head		Clamping Piece	Service Keys	Kit No.
	Boring Bar Range	Part No.	Serrated Tool Body	Insert Holder Range	Part No.	Insert Holder Range	Part No.			
m	10.00 - 15.00	218048	236021	29.00 - 41.00	236023	52.00 - 77.00	236027	236020	115575 (s2.5)	103052
	15.00 - 20.00	081041		40.00 - 53.00	236025	76.00 - 102.00	236029		215403 (s4)	
	20.00 - 25.00	081042							215521 (s5)	
	25.00 - 30.00	081043							115590 (T8)	

NOTE: Balancing elements and inserts sold separately



B10-M: 12-13

B10-A: 18

B10-H

B10: VI-VII

m = Metric (mm)

Inserts sold separately

IMPORTANT: Max spindle speed refers to maximum possible speed for an individual boring head and is not a recommended parameter. Refer to page B10-M: 12 for recommended application-specific parameters. Factory technical assistance is available for your specific applications through our Application Engineering department.
 email: engineering.eu@alliedmachine.com

Kit Components

Non-Digital | Insert Form 20 | Diameter Range: 10.00 mm - 102.00 mm

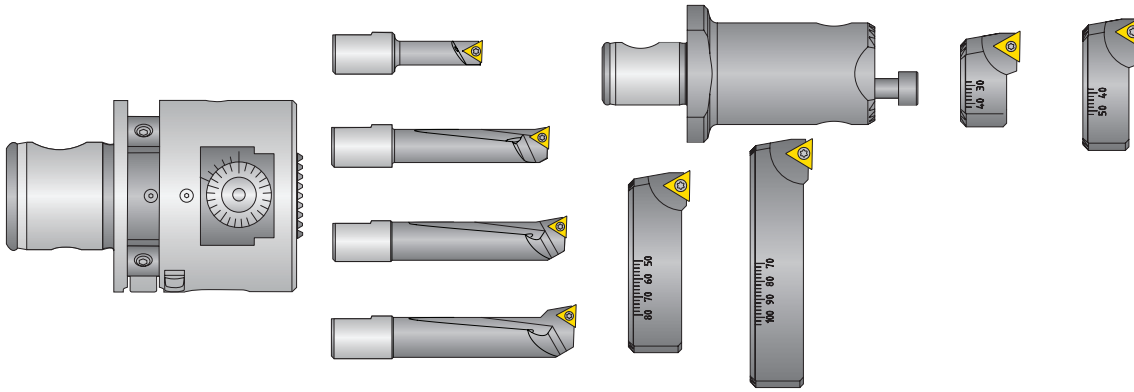

Diameter Range: 10.00 mm - 102.00 mm

Kit Components										
Boring Head	Boring Bars		Serrated Tool Body & Insert Holders			Insert Holders for Boring Head			Service Keys	Kit No.
	Boring Bar Range	Part No.	Serrated Tool Body	Insert Holder Range	Part No.	Insert Holder Range	Part No.	Clamping Piece		
Ⓜ	10.00 - 15.00	218059	236021	29.00 - 41.00	236022	52.00 - 77.00	236026	236020	115575 (s2.5)	103051
	15.00 - 20.00	081045		40.00 - 53.00		236024			76.00 - 102.00	
	20.00 - 25.00	081046						215521 (s5)		
	25.00 - 30.00	081047						115591 (T7)		

NOTE: Balancing elements and inserts sold separately



B10-M: 12-13

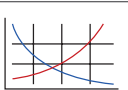

Key on B10-A-1

B10-A: 18

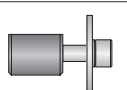

B10-H

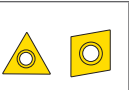

B10: VI-VII

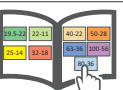

Ⓜ = Metric (mm)

Inserts sold separately

IMPORTANT: Max spindle speed refers to maximum possible speed for an individual boring head and is not a recommended parameter. Refer to page B10-M: 12 for recommended application-specific parameters. Factory technical assistance is available for your specific applications through our Application Engineering department.
 email: engineering.eu@alliedmachine.com

248 Product Overview

248 VERSATILE FINE BORING

Compact design. Precision boring.

The Wohlhaupter® 248 compact boring head allows for higher spindle speeds and achieves long-reach boring jobs. Its cylindrical shank provides variable length adjustments up to 10xD.

Test this **compact design** for finish machining today.

- Diameter range: 3.00 mm - 30.20 mm
- Length adjustment up to 10xD
- Through coolant boring tool
- 0.01 mm adjust on diameter
- Max spindle speed: 20,000 RPM



IMPORTANT: Max spindle speed refers to maximum possible speed for an individual boring head and is not a recommended parameter. Refer to page B10-M: 12 for recommended application-specific parameters. Factory technical assistance is available for your specific applications through our Application Engineering department.
email: engineering.eu@alliedmachine.com



248 Head



Insert Holder
Ø 15.90 mm - 30.20 mm



Adapter



Adapter



Boring Bar
Ø 3.70 mm - 16.00 mm



Mini Boring Bar
Ø 3.00 mm - 6.00 mm

OPERATION **VERSATILITY**

from **3.00 mm** to **30.20 mm**

Boring Heads

Diameter Range: 15.90 mm - 30.20 mm

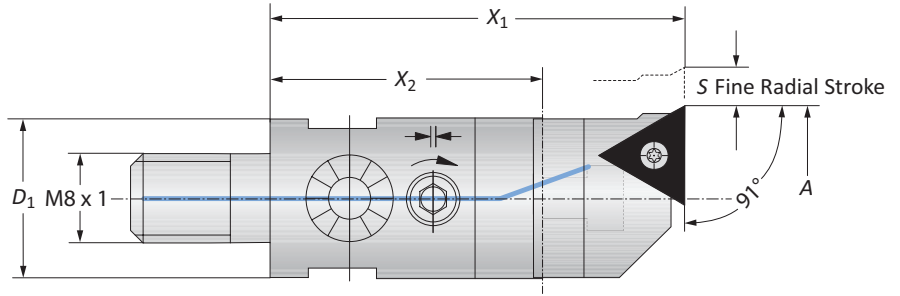

Boring Connection	Boring Range A	Boring Head				Weight	Insert Form	Part No.	
		X ₁	X ₂	D ₁	S			Insert Holder	Boring Head
M8 x 1	15.90 - 20.10	42.00	26.00	15.00	1.40	0.06 (kg)	20*	248051	248001
M8 x 1	15.90 - 20.10	42.00	26.00	15.00	1.40	0.06 (kg)	101	248054	248001
M8 x 1	19.90 - 24.80	46.00	30.00	18.00	1.80	0.09 (kg)	20*	248052	248002
M8 x 1	19.90 - 24.80	46.00	30.00	18.00	1.80	0.09 (kg)	101	248055	248002
M8 x 1	24.50 - 30.20	46.00	30.00	23.00	2.30	0.13 (kg)	20*	248053	248003
M8 x 1	24.50 - 30.20	46.00	30.00	23.00	2.30	0.13 (kg)	101	248056	248003

*Not suitable for indexable inserts with a radius of 0.80 mm

B10-M: 12-13

B10-A: 34

B10: VI-VII

Ⓜ = Metric (mm)

IMPORTANT: Max spindle speed refers to maximum possible speed for an individual boring head and is not a recommended parameter. Refer to page B10-M: 12 for recommended application-specific parameters. Factory technical assistance is available for your specific applications through our Application Engineering department.
 email: engineering.eu@alliedmachine.com

Mini Boring Bars

WHC05 | WHW04 | WBN150 | Diameter Range: 3.00 mm - 6.00 mm

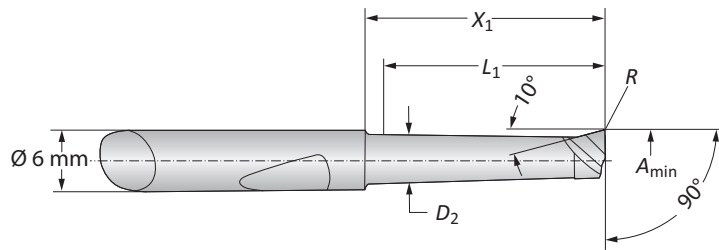

Mini Boring Bars

Boring Range	Boring Bar					Part No.			
	A_{min}	D_1	D_2	X_1	L_1	R	Coated Carbide	Uncoated Carbide	CBN
m	3.00	6.00	2.60	11.50	10.00	0.10	081306WHC05	-	081322WBN150
	3.00	6.00	2.60	16.50	15.00	0.10	081307WHC05	081307WHW04	-
	4.00	6.00	3.60	12.00	10.00	0.20	081308WHC05	-	081317WBN150
	4.00	6.00	3.60	17.00	15.00	0.20	081309WHC05	-	081341WBN150
	4.00	6.00	3.60	22.00	20.00	0.20	081310WHC05	081310WHW04	-
	5.00	6.00	4.60	12.00	10.00	0.20	081311WHC05	-	081318WBN150
	5.00	6.00	4.60	22.00	20.00	0.20	081312WHC05	-	081319WBN150
	5.00	6.00	4.60	32.00	30.00	0.20	081313WHC05	081313WHW04	-
	6.00	6.00	5.60	22.00	20.00	0.20	081314WHC05	-	081320WBN150
	6.00	6.00	5.60	32.00	30.00	0.20	081315WHC05	-	081321WBN150
6.00	6.00	5.60	42.00	40.00	0.20	081316WHC05	081316WHW04	-	

Adapter

Boring Head	Adapter				Part No.
	X_1	D_1	D_2	D_3	
m 248003	32.00	23.00	6.00	22.00	248071

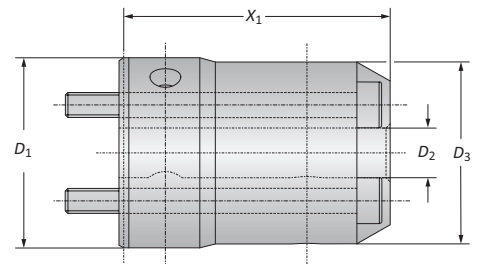

B10-M: 12-13
Key on B10-A: 1

B10-A: 34

B10: VI-VII

m = Metric (mm)

Boring Bars

Diameter Range: 3.70 mm - 16.00 mm

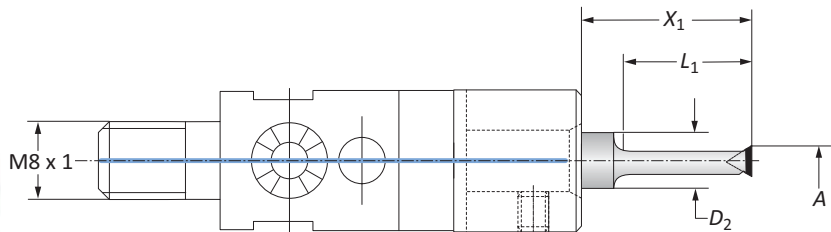

Boring Bars

Boring Range	Boring Bar				Insert Form	Part No.
	A	D ₂	X ₁	L ₁		
Ⓜ	3.70 - 5.00	8.00	20.80	18.00	325*	218074
	4.90 - 6.00	8.00	26.00	23.00	47*	218075
	5.90 - 8.00	8.00	27.00	25.00	211*	218076
	7.90 - 10.00	8.00	30.50	30.00	211*	218077
	9.90 - 12.00	8.00	35.00	35.00	20*	218079
	9.90 - 12.00	8.00	35.00	35.00	101	218082
	11.90 - 14.00	10.00	45.00	45.00	20*	218080
	11.90 - 14.00	10.00	45.00	45.00	101	218083
13.90 - 16.00	10.00	50.00	50.00	20*	218081	
13.90 - 16.00	10.00	50.00	50.00	101	218084	

*Not suitable for indexable inserts with a radius of 0.80 mm

Adapters

Boring Head	Adapter		Part No.
	D ₁	D ₂	
248002	18.00	8.00	248063
248003	23.00	8.00	248064
248003	23.00	10.00	248065

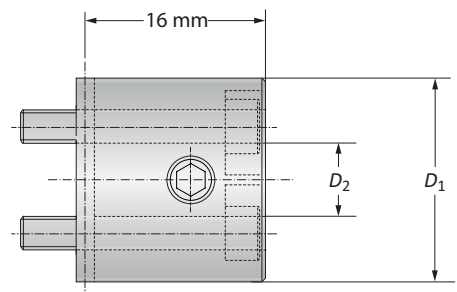

B10-M: 12-13

B10-H

B10: VI-VII

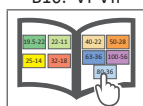
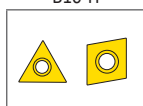
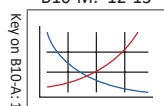

Adapters

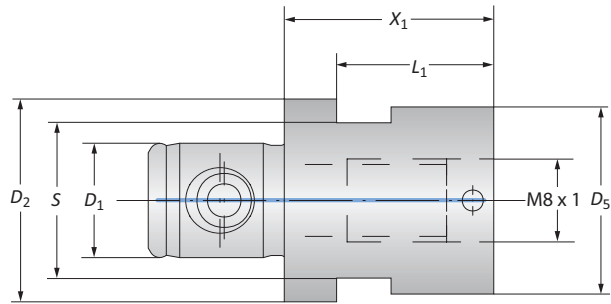

Adapters

MVS Connection	Boring Connection	Adapter				Weight	Service Key	Part No.
		$D_2 D_1$	X_1	L_1	S			
 19.5 - 11	M8 x 1	20.00	15.00	15/P	18.00	0.05 (kg)	15 S / P	219168
23 - 11	M8 x 1	20.00	-	19/P	23.00	0.07 (kg)	19 S / P	219169

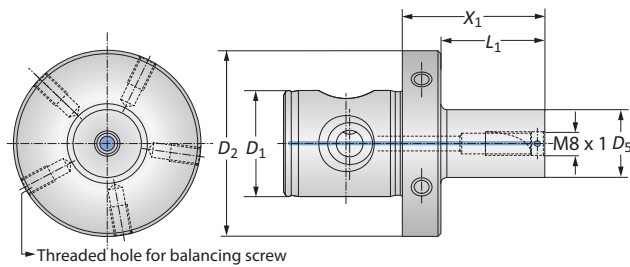

Balanced Adapters

MVS Connection	Boring Connection	Adapter			Weight	Balancing Screw	Part No.
		$D_2 D_1$	X_1	L_1			
 50 - 28	M8 x 1	32.00	19.00	15.00	0.35 (kg)	M6 x 1 x 10	219185
50 - 28	M8 x 1	48.00	35.00	18.00	0.40 (kg)	M6 x 1 x 10	219176
50 - 28	M8 x 1	48.00	35.00	23.00	0.45 (kg)	M6 x 1 x 10	219177

NOTE: Balance refers to a specific residual imbalance of ≤ 10 g mm/kg

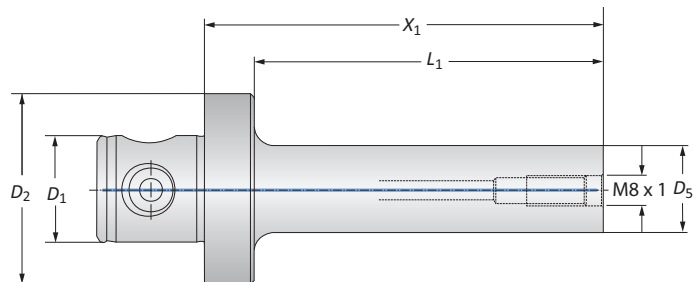

Vibration Reducing Heavy Metal Adapters

MVS Connection	Boring Connection	Adapter			Weight	Part No.
		$D_2 D_1$	X_1	L_1		
 50 - 28	M8 x 1	68.00	55.00	15.00	0.80 (kg)	248147
50 - 28	M8 x 1	84.00	71.00	19.00	1.00 (kg)	248148
50 - 28	M8 x 1	104.00	91.00	23.00	1.30 (kg)	248149

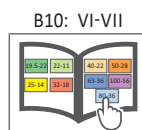
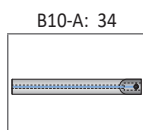
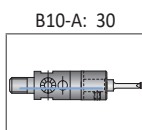
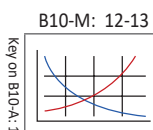

 = Metric (mm)

Shanks

Steel | Carbide

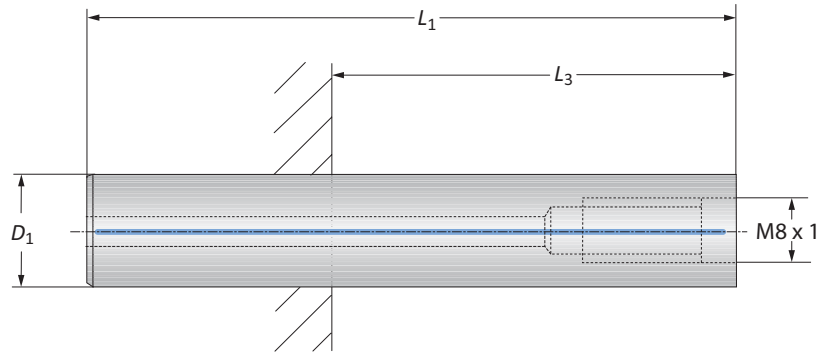

Steel Shanks

Connection	Shank			L_3 min*			Weight	Part No.
	D_1	L_1	L_3 max*	SK 40+50	HSK-A 63	HSK-A 100		
M8 x 1	15.00	85.00	37.00	–	–	–	0.10 (kg)	248136
M8 x 1	18.00	100.00	52.00	–	5.00	12.00	0.20 (kg)	248137
M8 x 1	23.00	117.00	69.00	–	22.00	29.00	0.40 (kg)	248138

* L_3 dimensions apply to collet chucks

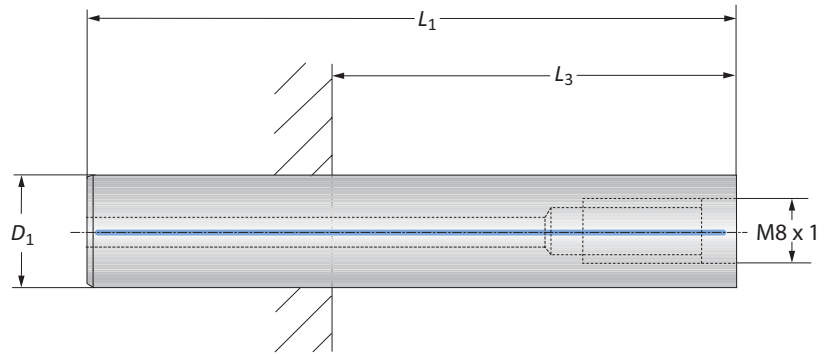
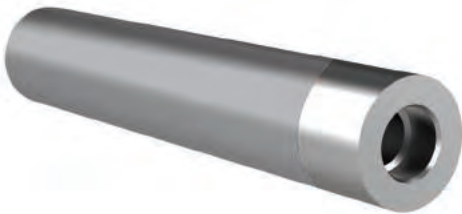

Carbide Shanks

Connection	Shank			L_3 min*				Weight	Part No.
	D_1	L_1	L_3 max*	SK 40	SK 50	HSK-A 63	HSK-A 100		
M8 x 1	15.00	130.00	82.00	20.00	20.00	35.00	42.00	0.30 (kg)	248142
M8 x 1	18.00	155.00	107.00	39.00	21.00	60.00	67.00	0.60 (kg)	248143
M8 x 1	23.00	180.00	132.00	64.00	46.00	85.00	92.00	1.10 (kg)	248144
M8 x 1	23.00	242.00	194.00	126.00	108.00	147.00	154.00	1.40 (kg)	248145

* L_3 dimensions apply to collet chucks

B10-M: 12-13

B10-A: 30

B10: vi-vii

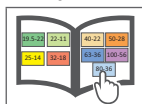
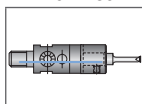
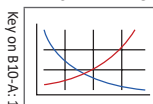

m = Metric (mm)

Accessories

Clamping Elements

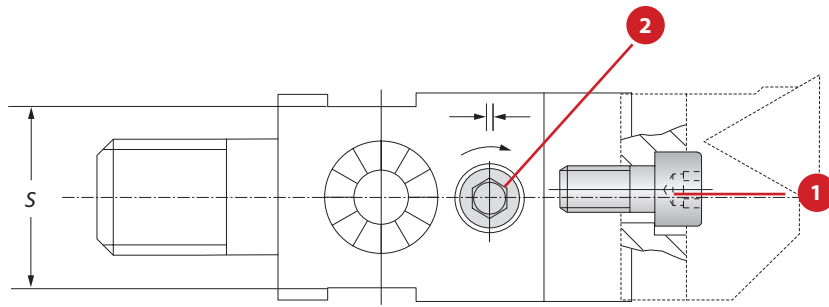

Clamping Elements for Boring Heads

Boring Head	Service Key	1 Cap Screw		2 Set Screw	
	S / Type	Part No.	Service Key	Part No.	Service Key
 248001	13 S / P	315631	s3 / A	315629	s2 / A
248002	15 S / P	315631	s3 / A	315684	s2 / A
248003	19 S / P	315631	s3 / A	315687	s2 / A

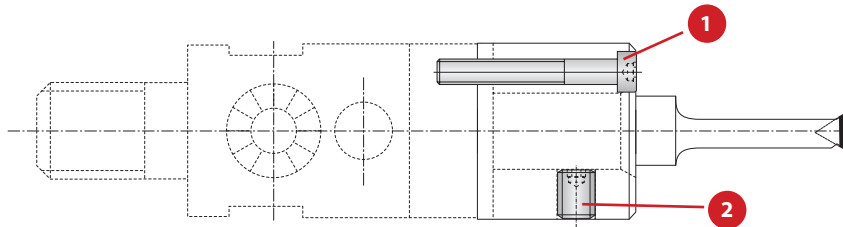

Clamping Elements for Adapters

Adapters	1 Cap Screw		2 Set Screw	
	Part No.	Service Key	Part No.	Service Key
 248063	315801	S 2.5 / A	115136	S 2.5 / A
248064	315801	S 2.5 / A	031141	S 2.5 / A
248065	315801	S 2.5 / A	031141	S 2.5 / A

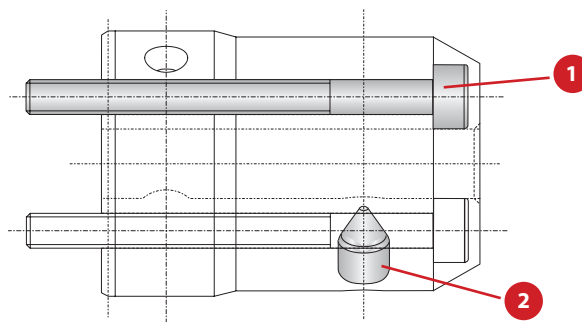

Screws for Adapter

Adapters	1 Cap Screw		2 Set Screw	
	Part No.	Service Key	Part No.	Service Key
 248071	515166	S 2.5 / A	415244	S 3 / A

 = Metric (mm)

PrimeBore Product Overview

PrimeBore VERSATILE FINE BORING

Advancing versatile technology.

With over 30 years of development, the Wohlhaupter® PrimeBore boring head offers versatility and precision. The PrimeBore head can bore multiple hole sizes ranging from 3.00 mm - 208.00 mm with our broad range of compatible boring bars.

Complete your boring job with *technology that continues to advance.*

- Diameter range: 3.00 mm - 208.00 mm
- Ease the stress of working on different day-to-day projects with boring kits
- 0.002 mm adjust on diameter
- Economical precision and versatility
- Max spindle speed: 12,000 RPM
- Through coolant



IMPORTANT: Max spindle speed refers to maximum possible speed for an individual boring head and is not a recommended parameter. Refer to page B10-M: 12 for recommended application-specific parameters. Factory technical assistance is available for your specific applications through our Application Engineering department.
email: engineering.eu@alliedmachine.com

PRIME BORE



PrimeBore Head

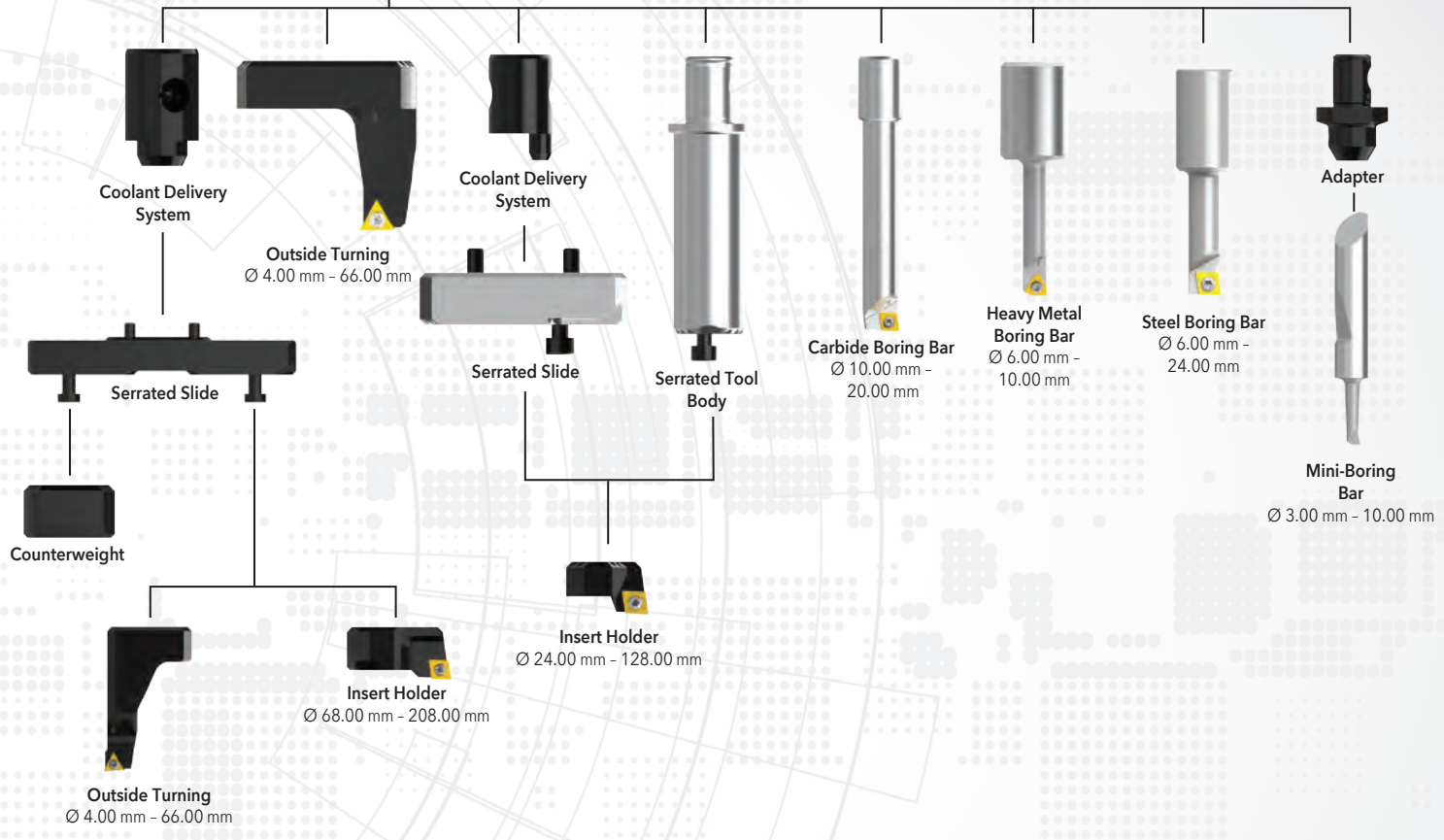

OPERATION **VERSATILITY**

from **3.00 mm** to **208.00 mm**
plus outside turning



Boring Heads

Diameter Range: 3.00 mm - 208.00 mm

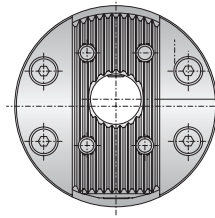

+ 4.5
- 0.1
Fine Radial Stroke

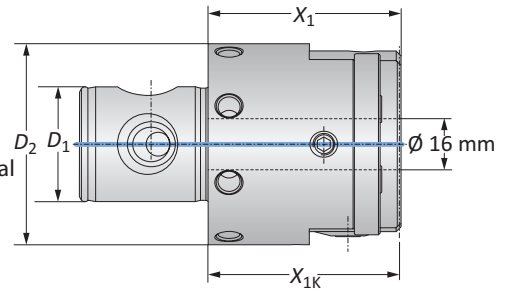

MVS Connection	Boring Head		Weight	Part No.	
	D_2 D_1	Boring Range			X_1
63 - 36	3.00 - 208.00	60.00	59.50	1.30 (kg)	450001

B10-M: 12-13

B10-F

B10: VI-VII

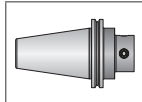
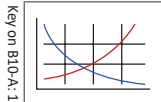

Key on B10-A:1

= Metric (mm)

IMPORTANT: Max spindle speed refers to maximum possible speed for an individual boring head and is not a recommended parameter. Refer to page B10-M: 12 for recommended application-specific parameters. Factory technical assistance is available for your specific applications through our Application Engineering department.
email: engineering.eu@alliedmachine.com

Mini Boring Bars

WHC05 | WHW04 | WBN150 | Diameter Range: 3.00 mm - 10.00 mm

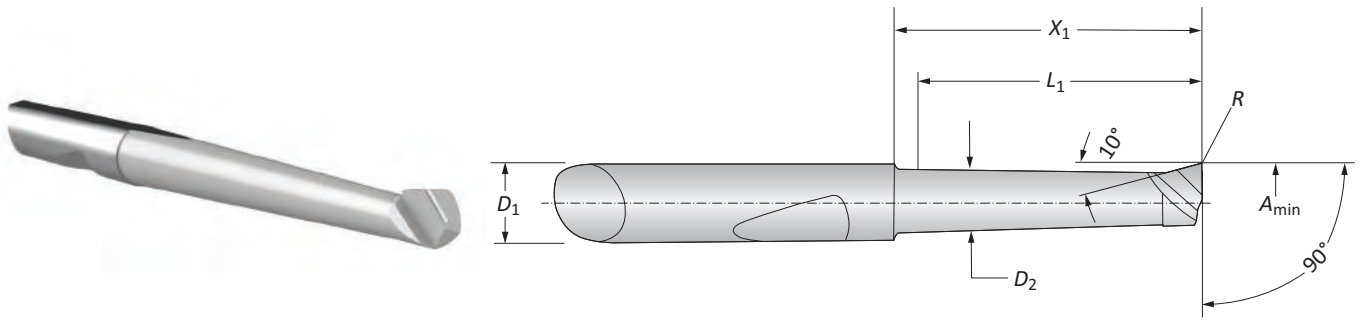

Mini Boring Bars

Boring Range	Boring Bar					Part No.			
	A_{min}	D_1	D_2	X_1	L_1	R	Coated Carbide	Uncoated Carbide	CBN
m	3.00	6.00	2.60	11.50	10.00	0.10	081306WHC05	-	081322WBN150
	3.00	6.00	2.60	16.50	15.00	0.10	081307WHC05	081307WHW04	-
	4.00	6.00	3.60	12.00	10.00	0.20	081308WHC05	-	081317WBN150
	4.00	6.00	3.60	17.00	15.00	0.20	081309WHC05	-	081341WBN150
	4.00	6.00	3.60	22.00	20.00	0.20	081310WHC05	081310WHW04	-
	5.00	6.00	4.60	12.00	10.00	0.20	081311WHC05	-	081318WBN150
	5.00	6.00	4.60	22.00	20.00	0.20	081312WHC05	-	081319WBN150
	5.00	6.00	4.60	32.00	30.00	0.20	081313WHC05	081313WHW04	-
	6.00	6.00	5.60	22.00	20.00	0.20	081314WHC05	-	081320WBN150
	6.00	6.00	5.60	32.00	30.00	0.20	081315WHC05	-	081321WBN150
	6.00	6.00	5.60	42.00	40.00	0.20	081316WHC05	081316WHW04	-
	8.00	8.00	7.60	25.00	23.00	0.20	081323WHC05	-	-
	8.00	8.00	7.60	50.00	48.00	0.20	081324WHC05	-	-



Adapters

	Adapter				Part No.
	D_3	D_5	X_1	L_1	
m	6.00	20.00	22.50	14.00	319010
	8.00	22.00	22.50	14.00	236071

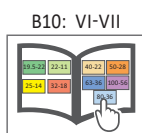
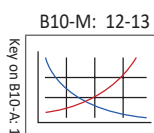
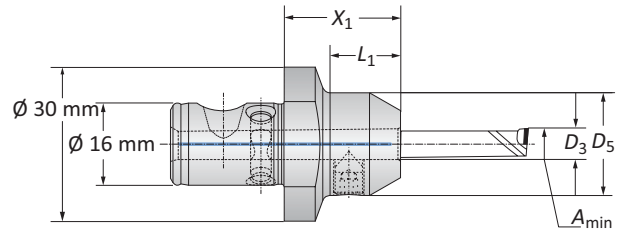

m = Metric (mm)

Boring Bars

Steel | Heavy Metal

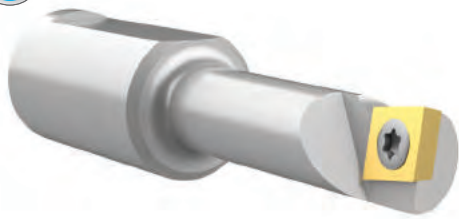

Form 101

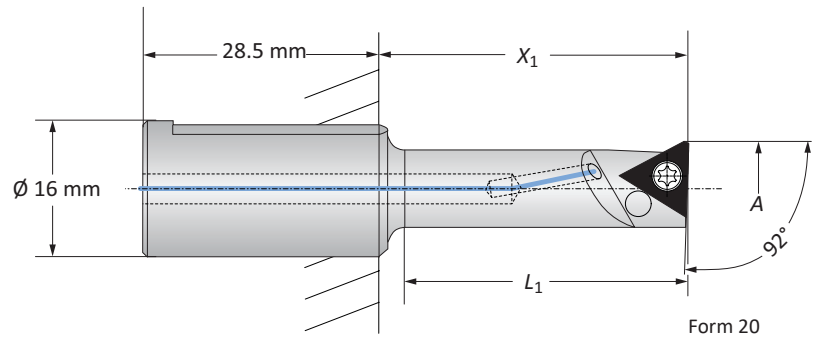

Steel Boring Bars | Diameter Range: 6.00 mm - 24.00 mm

	Boring Range		Boring Bar		Weight	Insert Form	Part No.
	A	X ₁	L ₁				
m	6.00 - 10.00	22.00 - 32.00	20.00		0.04 (kg)	211*	450026
	10.00 - 16.00	35.00 - 45.00	33.00		0.06 (kg)	101	450027
	10.00 - 16.00	35.00 - 45.00	33.00		0.06 (kg)	20*	450038
	16.00 - 24.00	60.00 - 70.00	58.00		0.10 (kg)	101	450028
	16.00 - 24.00	60.00 - 70.00	58.00		0.10 (kg)	20*	450039

*Not suitable for indexable inserts with a radius of 0.80 mm

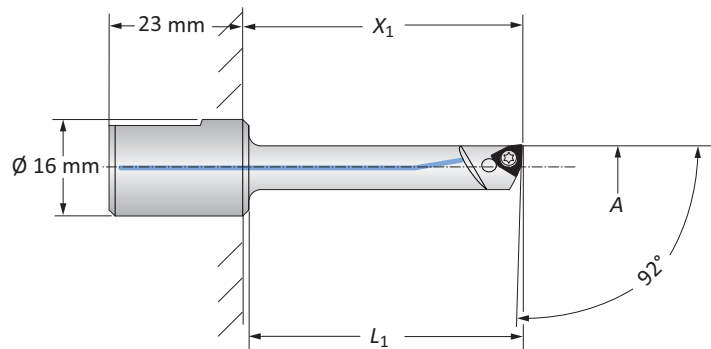

Heavy Metal Boring Bars | Diameter Range: 6.00 mm - 10.00 mm

	Boring Range		Boring Bar		Weight	Insert Form	Part No.
	A	X ₁	L ₁				
m	6.00 - 8.00	32.00	29.00		0.08 (kg)	211*	081055
	8.00 - 10.00	45.00	42.00		0.09 (kg)	211*	218072

*Not suitable for indexable inserts with a radius of 0.80 mm

B10-M: 12-13 B10-H B10: VI-VII

m = Metric (mm)
Inserts sold separately

Boring Bars

Carbide | Diameter Range: 10.00 mm - 20.00 mm



Form 101

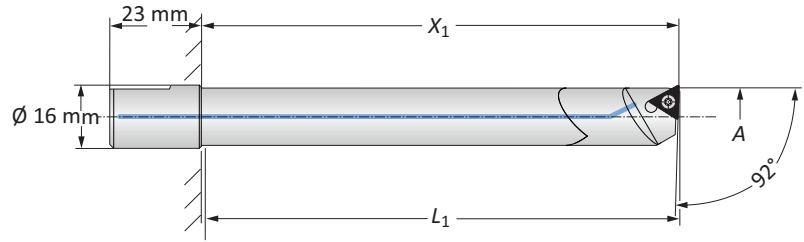

Form 20

Carbide Boring Bars

	Boring Range		Boring Bar		Weight	Insert Form	Part No.	Insert Form	Part No.
	A	X ₁	L ₁						
m	10.00 - 12.00	55.00	52.00	0.07 (kg)	101	218042	20*	218037	
	10.00 - 12.00	75.00	72.00	0.09 (kg)	101	218032	20*	218029	
	12.00 - 14.00	70.00	67.00	0.10 (kg)	101	218043	20*	218038	
	12.00 - 14.00	90.00	87.00	0.15 (kg)	101	218033	20*	218030	
	14.00 - 16.00	75.00	72.00	0.16 (kg)	101	218044	20*	218039	
	14.00 - 16.00	100.00	97.00	0.20 (kg)	101	218045	20*	218040	
	16.00 - 20.00	90.00	87.00	0.26 (kg)	101	218046	20*	218041	
	16.00 - 20.00	120.00	117.00	0.33 (kg)	101	218034	20*	218031	

*Not suitable for indexable inserts with a radius of 0.80 mm

B10-M: 12-13

Key on B10-A: 1

B10-H

B10: VI-VII

m = Metric (mm)
Inserts sold separately

Serrated Tool Bodies | Insert Holders

Diameter Range: 24.00 mm - 65.00 mm

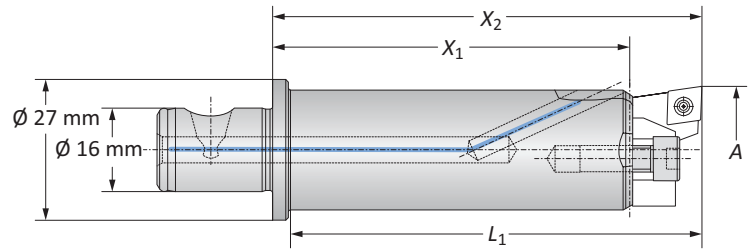

Serrated Tool Body

Boring Range	Serrated Tool Body			Weight	Part No.
A	X ₁	X ₂	L ₁		
24.00 - 65.00	68.00	82.00	79.00	0.20 (kg)	450021

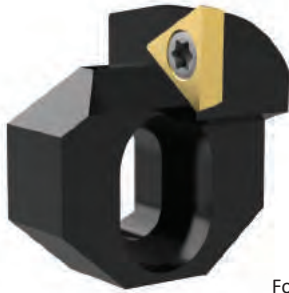

Form 20

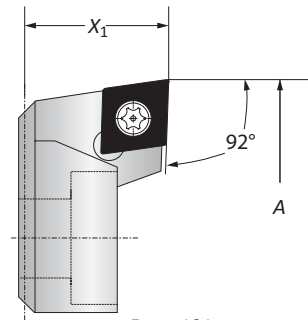

Form 101

Insert Holders

Boring Range	Insert Holder	Weight	Insert Form	Part No.
A	X ₁			
24.00 - 40.00	14.00	0.02 (kg)	101	450022
24.00 - 40.00	14.00	0.02 (kg)	20*	450040
40.00 - 65.00	14.00	0.03 (kg)	101	450023
40.00 - 65.00	14.00	0.03 (kg)	20*	450041

*Not suitable for indexable inserts with a radius of 0.80 mm

B10-M: 12-13

B10-A: 47

B10-H

B10: VI-VII

m = Metric (mm)
Inserts sold separately

Serrated Slides | Insert Holders

Diameter Range: 65.00 mm - 128.00 mm

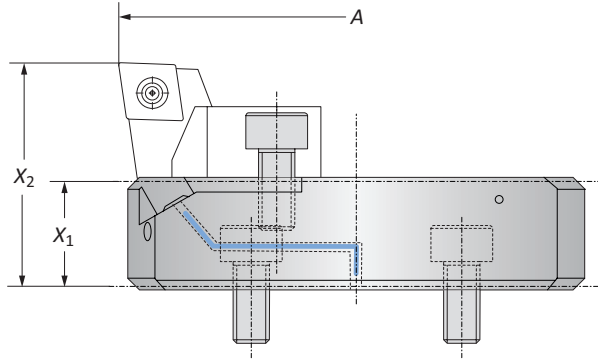

Serrated Slides

Boring Range	Serrated Slide		Weight	Part No.
	A	X ₁		
 65.00 - 128.00	14.50	29.50	0.08 (kg)	450024

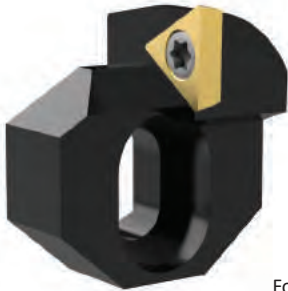

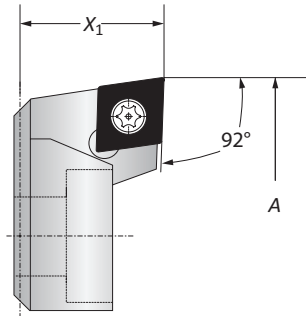

Form 20



Form 101

Insert Holders

Boring Range	Insert Holder	Weight	Insert Form	Part No.
A	X ₁			
 65.00 - 128.00	14.00	0.03 (kg)	101	450023
 65.00 - 128.00	14.00	0.03 (kg)	20*	450041

*Not suitable for indexable inserts with a radius of 0.80 mm



Alu-Line Coolant Delivery Section

Coolant Delivery Section		
X ₁	Weight	Part No.
 26.75	0.01 (kg)	450125

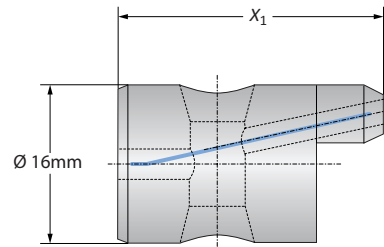

B10-M: 12-13
Key on B10-A-1

B10-A: 47

B10-H

B10: VI-VII

 = Metric (mm)
Inserts sold separately

Alu-Line Serrated Slides | Insert Holders

Diameter Range: 68.00 mm - 208.00 mm

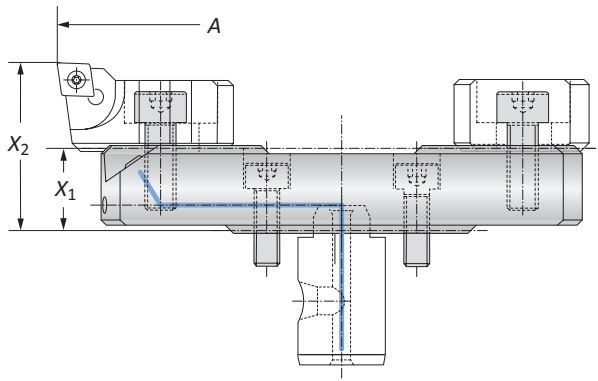

Alu-Line Serrated Slides

	Boring Range		Serrated Slide		Weight	Part No.
	A	X ₁	X ₂			
	68.00 - 96.00	16.00	32.50		0.10 (kg)	501054
	96.00 - 124.00	16.00	32.50		0.10 (kg)	501055
m	124.00 - 152.00	16.00	32.50		0.20 (kg)	501056
	152.00 - 180.00	22.00	38.50		0.25 (kg)	501058
	180.00 - 208.00	22.00	38.50		0.30 (kg)	501059

Insert Holders

	Boring Range		Insert Form	Part No.
	A	Weight		
m	68.00 - 208.00	0.05 (kg)	101	502064
	68.00 - 208.00	0.05 (kg)	20	502069

NOTE: Other insert holders available upon request



Form 20

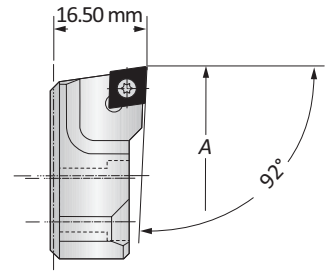

Form 101

Counterweight

	Counterweight		Part No.
	X ₁	Weight	
m	13.40	0.05 (kg)	502165

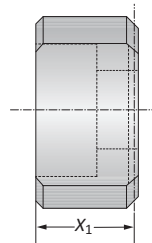

Alu-Line Coolant Delivery Section

	Coolant Delivery Section		Part No.
	X ₁	Weight	
m	25.50	0.01 (kg)	450137

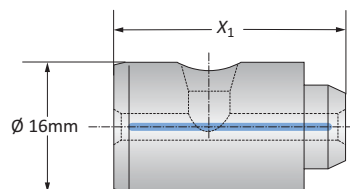

B10-M: 12-13

B10-A: 47

B10-H

B10: VI-VII

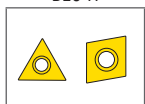
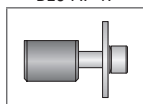
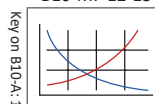

m = Metric (mm)
Inserts sold separately

Outside Turning Insert Holders for Boring Heads

Diameter Range: 4.00 mm - 66.00 mm

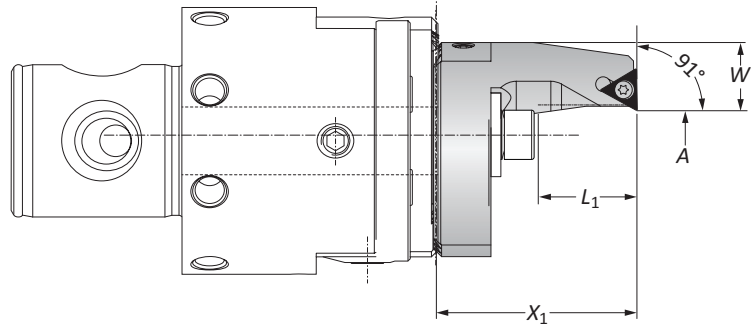

Type A Insert Holders | Diameter Range: 4.00 mm - 30.00 mm

Metric	Boring Range		Insert Holder			Weight	Type	Insert Form	Part No.
	A	X ₁	L ₁	W					
m	4.00 - 17.50	40.50	20.00	16.60	0.10 (kg)	A	20*	236081	
	16.50 - 30.00	50.50	30.00	11.10	0.10 (kg)	A	20*	236082	

NOTE: Clockwise and neutral execution

*Not suitable for indexable inserts with a radius of 0.80 mm

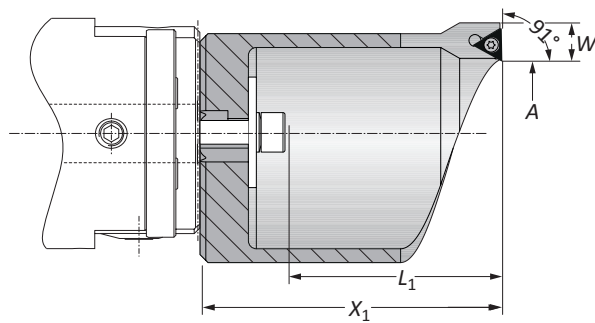

Type B Insert Holders | Diameter Range: 29.00 mm - 66.00 mm

Metric	Boring Range		Insert Holder			Weight	Type	Insert Form	Part No.
	A	X ₁	L ₁	W					
m	29.00 - 44.00	75.50	54.00	9.60	0.30 (kg)	B	20*	236083	
	43.00 - 66.00	100.50	79.00	9.60	0.40 (kg)	B	20*	236084	

NOTE: Clockwise and neutral execution

*Not suitable for indexable inserts with a radius of 0.80 mm

Clamping Pieces for Outside Turning Insert Holders

Insert Holder Type	Boring Range	Service Key	Complete Part No.
A	4.00 - 30.00	s5	236088
B	29.00 - 66.00	s5	236089

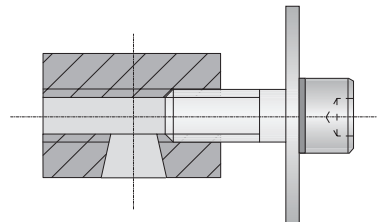

Key on B10-A-1

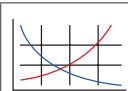
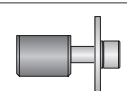
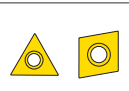
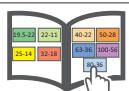
B10-M: 12-13 	B10-A: 47 	B10-H 	B10: VI-VII 
---	--	--	--

m = Metric (mm)
Inserts sold separately

Outside Turning Serrated Slides | Insert Holders

Diameter Range: 2.00 mm - 114.00 mm

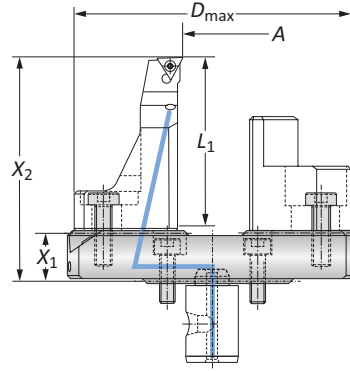

Outside Turning Serrated Slides

	Boring Range	Serrated Slide				Weight	Part No.
	A	X ₁	X ₂	L ₁	D _{max}		
m	2.00 - 30.00	16.00	73.00	55.00	101.00	0.35 (kg)	501064
	30.00 - 58.00	16.00	73.00	55.00	129.00	0.44 (kg)	501065
	58.00 - 86.00	22.00	79.00	55.00	157.00	0.60 (kg)	501066
	86.00 - 114.00	22.00	79.00	55.00	185.00	0.73 (kg)	501067

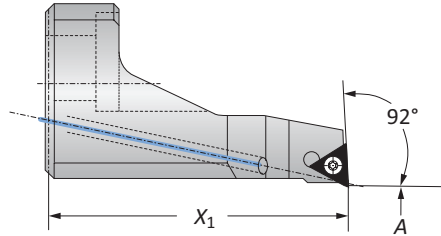

Insert Holder

	Outside Turning Range	Insert Holder	Weight	Insert Form	Part No.
	A	X ₁			
m	2.00 - 114.00	57.00	0.15 (kg)	20	502082

NOTE: clockwise and neutral execution

Counterweight

	Counterweight	Weight	Part No.
	X ₁		
m	37.75	0.16 (kg)	502183

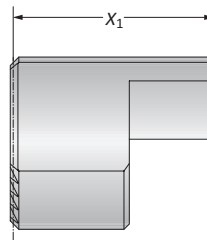

Coolant Delivery Section

	Coolant Delivery Section	Weight	Part No.
	X ₁		
m	25.50	0.01 (kg)	450137

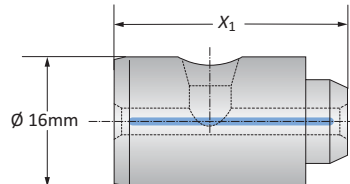

B10-M: 12-13

Key on B10-A-1

B10-A: 47

B10-H

B10: VI-VII

B10-A: 46

www.alliedmachine.com | +44 (0) 1384 400 900 | enquiries.eu@alliedmachine.com

m = Metric (mm)
Inserts sold separately

Accessories

Clamping Elements

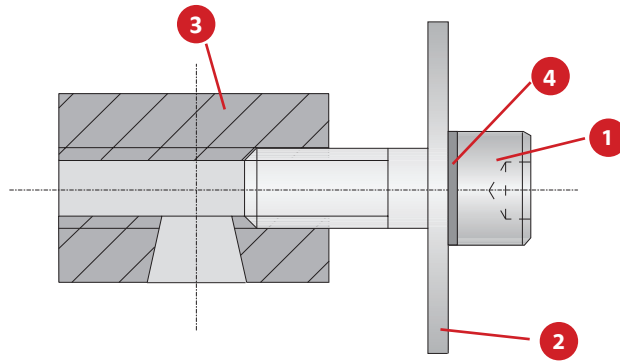

Clamping Elements for Insert Holders

	1		2	3	4	
Boring Range	Cap Screw	Hex Size	Washer	Clamping Nut	Locking Washer	Complete Part No.
m 4.00 - 30.00	070153	s5	315155	236120	215254	236088
29.00 - 66.00	070153	s5	315156	236120	215254	236089

Clamping Elements for Serrated Tool Body

1		2
Cap Screw	Hex Size	Clamping Piece
027154	s4	145184

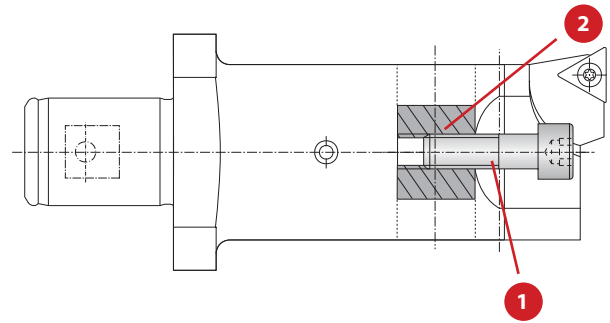

Thread Pin

	1
Service Key	Part No.
S3 / A	415244

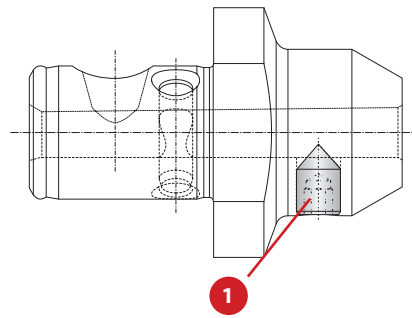

m = Metric (mm)

Kit Components

Form 101 | Diameter Range: 6.00 mm - 128.00 mm

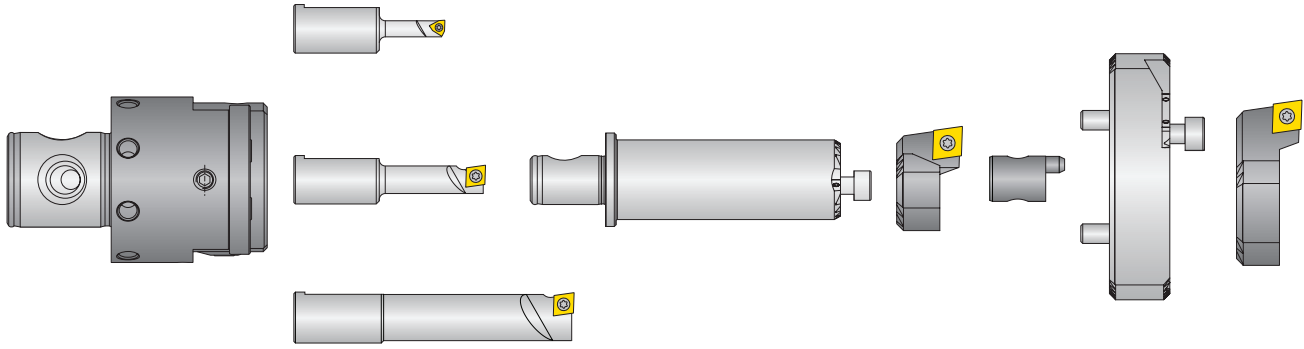

Diameter Range: 6.00 mm - 128.00 mm

Kit Components										
Boring Head	Boring Bars		Insert Holders		Serrated Tool Body	Serrated Slide	Coolant Delivery Section	Service Keys	Kit No.	
	Boring Range	Part No.	Boring Range	Part No.						
Ⓜ 450001	6.00 - 10.00	450026 (Form 211)	24.00 - 40.00	450022	450021	450024	450125	003195 (s4) 515451 (T6) 515452 (T8)	103088	
	10.00 - 16.00	450027 (Form 101)	40.00 - 65.00	450023						
	16.00 - 24.00	450028 (Form 101)								

NOTE: Inserts sold separately



B10-M: 12-13

B10-H

B10: VI-VII

Key on B10-A: 1

Ⓜ = Metric (mm)

Inserts sold separately

IMPORTANT: Max spindle speed refers to maximum possible speed for an individual boring head and is not a recommended parameter. Refer to page B10-M: 12 for recommended application-specific parameters. Factory technical assistance is available for your specific applications through our Application Engineering department.
 email: engineering.eu@alliedmachine.com

Kit Components

Form 20 | Diameter Range: 6.00 mm - 128.00 mm

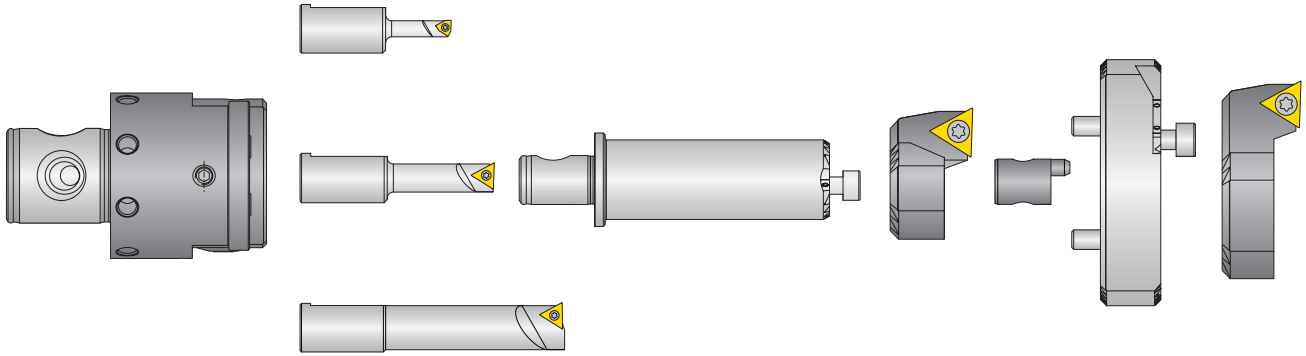

Diameter Range: 6.00 mm - 128.00 mm

Kit Components										
Boring Head	Boring Bars		Insert Holders		Serrated Tool Body	Serrated Slide	Coolant Delivery Section	Service Keys	Kit No.	
	Boring Range	Part No.	Boring Range	Part No.						
Ⓜ	450001	6.00 - 10.00	450026 (Form 211)	24.00 - 40.00	450040	450021	450024	450125	003195 (s4)	103089
		10.00 - 16.00	450038 (Form 20)	40.00 - 65.00	450041				515451 (T6)	
		16.00 - 24.00	450039 (Form 20)						515453 (T7)	

NOTE: Inserts sold separately



B10-M: 12-13

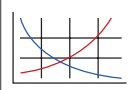

Key on B10-A: 1

B10-H

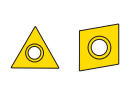

B10: VI-VII

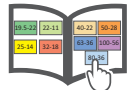

Ⓜ = Metric (mm)
Inserts sold separately

IMPORTANT: Max spindle speed refers to maximum possible speed for an individual boring head and is not a recommended parameter. Refer to page B10-M: 12 for recommended application-specific parameters. Factory technical assistance is available for your specific applications through our Application Engineering department.
email: engineering.eu@alliedmachine.com

Digital 510 Product Overview

Digital 510 VERSATILE FINE BORING

Improve your boring job with the Digital 510 boring head.

The Wohlhaupter® Digital 510 boring head offers precision, quality, and efficiency. Our integrated digital display makes the 510 the smallest precision boring tool available and allows for easy optoelectronic adjusting.

Experience *precision boring* for yourself.

- Diameter range: 0.40 mm - 12.00 mm
- Easy-to-read digital display
- Through coolant
- External counterweight for balancing
- Protected against coolant and dust according to IP65
- Fine adjustments of 0.002 mm
- Ideal for CAT40, BT30, HSK40
- Max spindle speed: 35,000 RPM



NOTE: Adjustment accuracy of 0.002 mm on diameter

IMPORTANT: Max spindle speed refers to maximum possible speed for an individual boring head and is not a recommended parameter. Refer to page B10-M: 12 for recommended application-specific parameters. Factory technical assistance is available for your specific applications through our Application Engineering department.
email: engineering.eu@alliedmachine.com

DIGITAL



NOTE: Adjustment accuracy of 0.002 mm on diameter

Digital 510001 Boring Head
0.40 mm - 12.00 mm

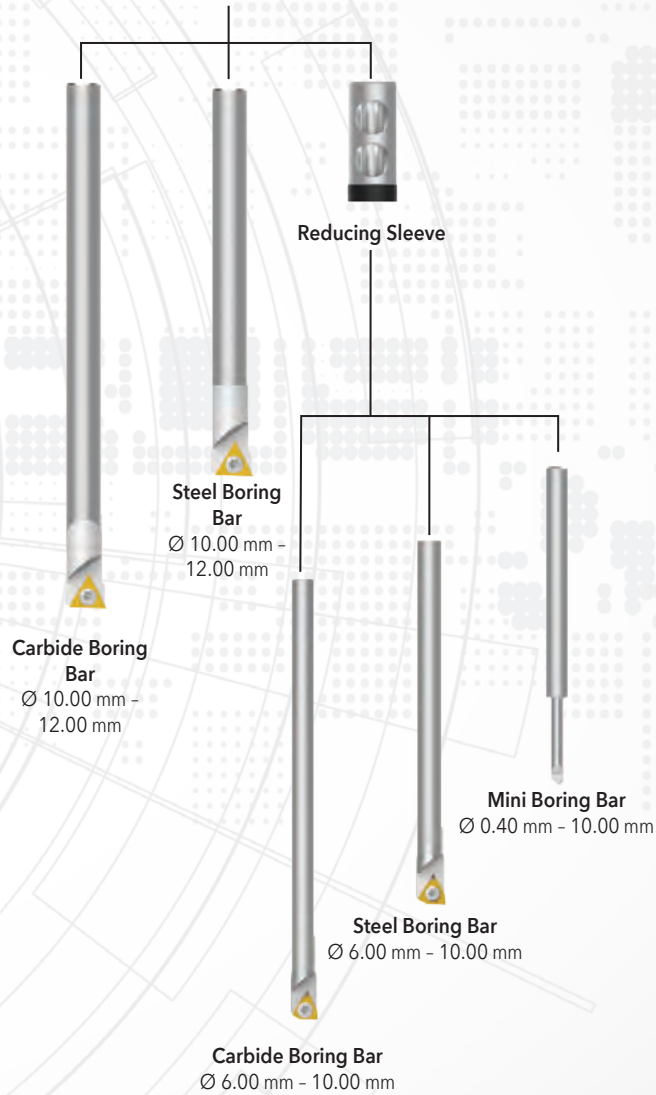

OPERATION **VERSATILITY**

from **0.40 mm** to **12.00 mm**

Boring Heads

Diameter Range: 0.40 mm - 12.00 mm

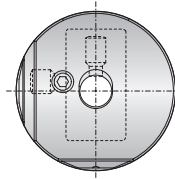

Fine Radial Stroke
+1.1 mm
-0.1 mm

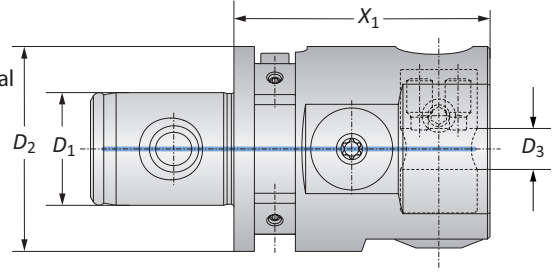

NOTE: Adjustment accuracy of 0.002 mm on diameter

Boring Heads

MVS Connection	Boring Range	Boring Head		Weight	Part No.
		D_3	X_1		
$D_2 D_1$ 40 - 22	0.40 - 12.00	8.00	50.00	0.42 (kg)	510001

B10-M: 12-13

B10-F

B10: VI-VII

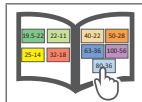
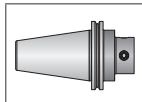
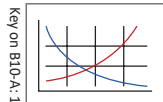

Key on B10-A:1

m = Metric (mm)

IMPORTANT: Max spindle speed refers to maximum possible speed for an individual boring head and is not a recommended parameter. Refer to page B10-M: 12 for recommended application-specific parameters. Factory technical assistance is available for your specific applications through our Application Engineering department.
email: engineering.eu@alliedmachine.com

Mini Boring Bars

Diameter Range: 0.40 mm - 5.00 mm

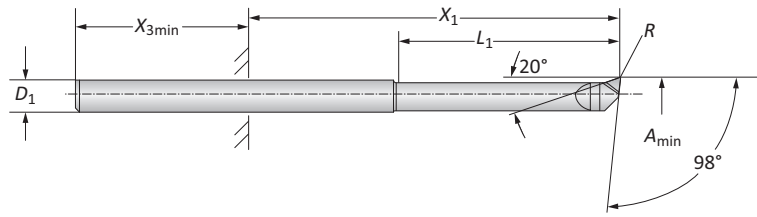

Mini Boring Bars

	Boring Range		Boring Bar				Part No.
	A_{min}	D_1	X_1	$X_{3\ min}$	L_1	R	
	0.40	4.00*	3.00 - 26.00	16.00	2.00	0.03	081401WHC126
	0.60	4.00*	4.00 - 27.00	16.00	3.00	0.04	081402WHC126
	0.80	4.00*	5.00 - 28.00	16.00	4.00	0.04	081403WHC126
	1.00	4.00*	6.00 - 29.00	16.00	5.00	0.05	081404WHC126
	1.50	4.00*	8.50 - 31.50	16.00	7.50	0.05	081405WHC126
	2.00	4.00*	11.00 - 34.00	16.00	10.00	0.05	081406WHC126
	2.50	4.00*	13.50 - 36.50	16.00	12.50	0.05	081407WHC126
	2.80	4.00*	15.00 - 38.00	16.00	14.00	0.07	081408WHC126

*Fixture-through reducing sleeve required (B10-A: 58)

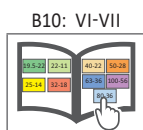
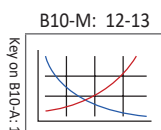

 = Metric (mm)

Mini Boring Bars

WHC05 | WHW04 | WBN150 | Diameter Range: 3.00 mm - 10.00 mm

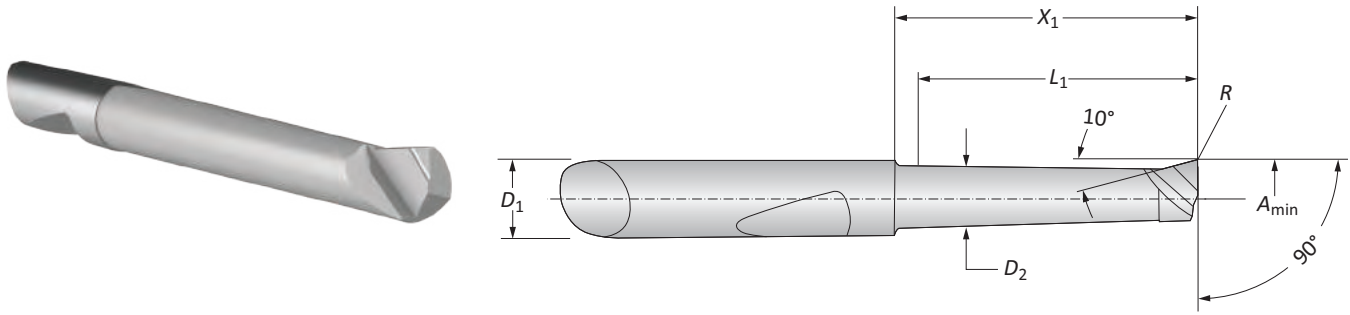

Boring Range	Boring Bar					Part No.			
	A_{min}	D_1	D_2	X_1	L_1	R	Coated Carbide	Uncoated Carbide	CBN
m	3.00	6.00*	2.60	11.50	10.00	0.10	081306WHC05	-	081322WBN150
	3.00	6.00*	2.60	16.50	15.00	0.10	081307WHC05	081307WHW04	-
	4.00	6.00*	3.60	12.00	10.00	0.20	081308WHC05	-	081317WBN150
	4.00	6.00*	3.60	17.00	15.00	0.20	081309WHC05	-	081341WBN150
	4.00	6.00*	3.60	22.00	20.00	0.20	081310WHC05	081310WHW04	-
	5.00	6.00*	4.60	12.00	10.00	0.20	081311WHC05	-	081318WBN150
	5.00	6.00*	4.60	22.00	20.00	0.20	081312WHC05	-	081319WBN150
	5.00	6.00*	4.60	32.00	30.00	0.20	081313WHC05	081313WHW04	-
	6.00	6.00*	5.60	22.00	20.00	0.20	081314WHC05	-	081320WBN150
	6.00	6.00*	5.60	32.00	30.00	0.20	081315WHC05	-	081321WBN150
G	6.00	6.00*	5.60	42.00	40.00	0.20	081316WHC05	081316WHW04	-
	8.00	8.00*	7.60	25.00	23.00	0.20	081323WHC05	-	-
8.00	8.00*	7.60	50.00	48.00	0.20	081324WHC05	-	-	

*Fixture-through reducing sleeve required (B10-A: 58)

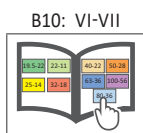
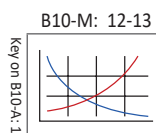

m = Metric (mm)

Boring Bars

Steel | Diameter Range: 6.00 mm - 12.00 mm



Form 101

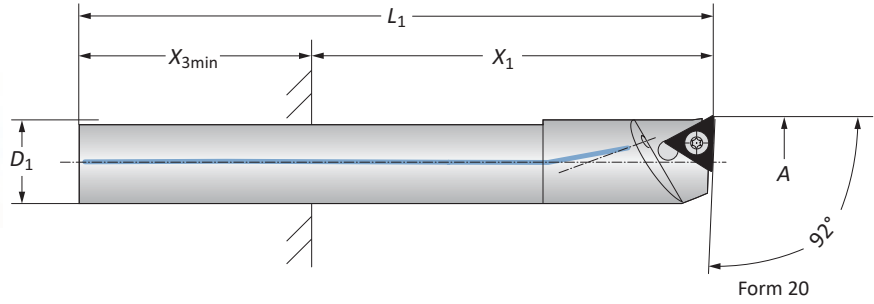

	Boring Range		Boring Bar				Part No.			
	A	D ₁	X ₁	X _{3 min}	L ₁	Weight	Insert Form	Boring Bar	Insert Form	Boring Bar
	6.00 - 8.00	5.00*	12.50 - 25.00	16.00	70.00	0.01 (kg)	211**	514032	-	-
	8.00 - 10.00	7.00*	17.50 - 35.00	16.00	81.00	0.02 (kg)	211**	514033	-	-
	10.00 - 12.00	8.00	20.00 - 40.00	19.00	85.00	0.03 (kg)	101	514003	20**	514004

*Fixture-through reducing sleeve required (B10-A: 58)

**Not suitable for indexable inserts with a radius of 0.8 mm

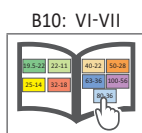
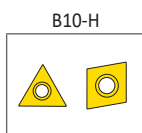
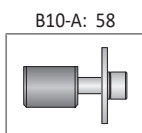
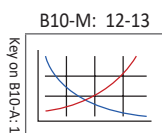

 = Metric (mm)
Inserts sold separately

Boring Bars

Carbide | Diameter Range: 6.00 mm - 12.00 mm



Form 101

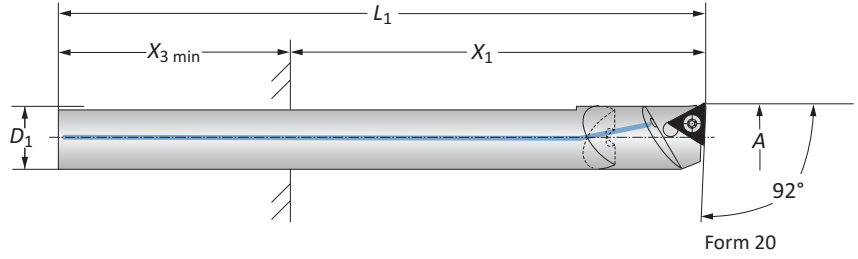

Form 20

Boring Range	Boring Bar				Weight	Part No.			
	A	D ₁	X ₁	X _{3 min}		L ₁	Insert Form	Boring Bar	Insert Form
6.00 - 8.00	5.00*	12.50 - 40.00	16.00	90.00	0.02 (kg)	211**	514034	-	-
8.00 - 10.00	7.00*	21.00 - 56.00	16.00	109.00	0.05 (kg)	211**	514035	-	-
10.00 - 12.00	8.00	22.00 - 64.00	19.00	117.00	0.07 (kg)	101	514015	20**	514016

*Fixture-through reducing sleeve required (B10-A: 58)

**Not suitable for indexable inserts with a radius of 0.80 mm

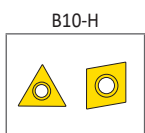
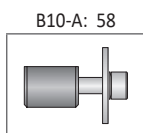
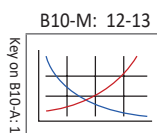

m = Metric (mm)
Inserts sold separately

Reducing Sleeves

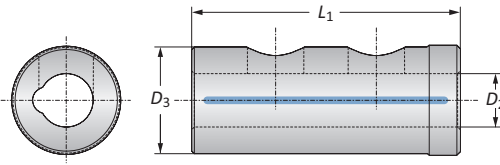

Reducing Sleeve				Part No.
D_3	D_2	L_1		
8.00	4.00	20.00		514201
8.00	5.00	20.00		514202
8.00	6.00	20.00		514210
8.00	7.00	20.00		514203

Ⓜ

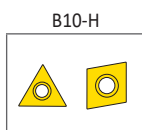
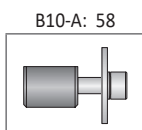
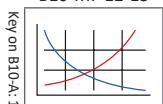

Ⓜ = Metric (mm)
Inserts sold separately

Boring Head Accessories

No.	Part	Insert Form	Size	Part No.
				510001
1	Clamping screw	-	-	115985
2	Thread pin for tool clamping	-	-	070333
3	Sealing ring for battery cover	-	-	415895
4	Battery*	-	-	415896
5	Battery cover with sealing ring	-	-	501016
6	Thread pin	-	-	510114
7	Insert screws	Form 20 Form 101 Form 211	T7 T8 T6	115535 115676 515286
8	Clamping Screw	-	T25	415112
9	Hex wrench	-	s2	215473
10	Hex wrench	-	s2.5 s3.0 s4.0	415577 415578 115576
11	Torx driver	-	T6 T7 T8 T20	115537 115591 115590 215150
12	Torx screw-driver	Form 211 Form 20 Form 101	T6 T7 T8	415507 415508 415514

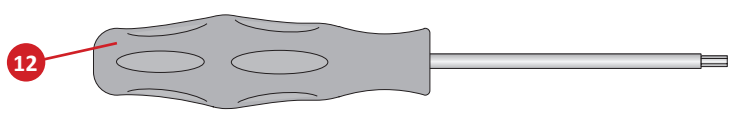
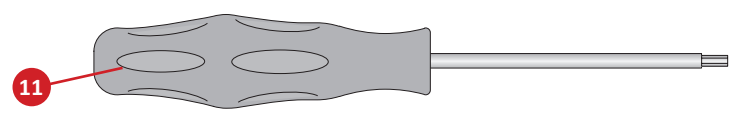
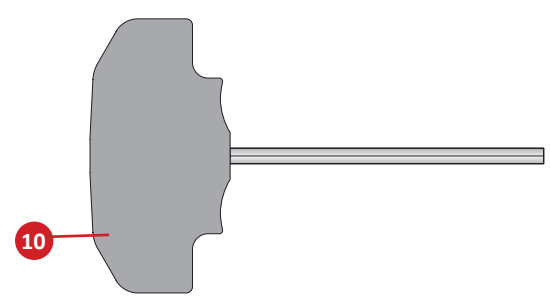
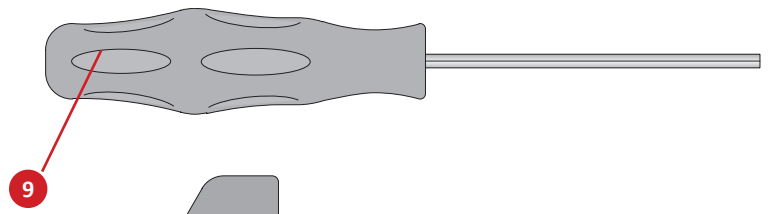
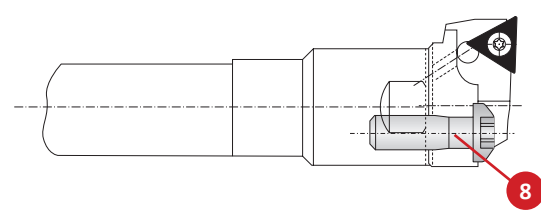
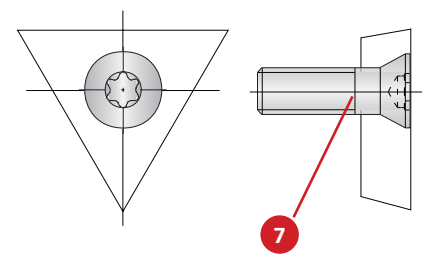
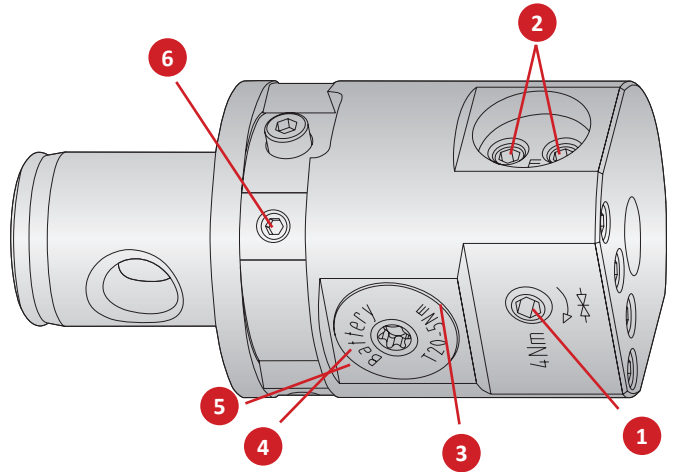

*Always change two batteries
NOTE: Please use VARTA batteries

A
B
C
D
E
F
G
H
I
J
K
L
M
INDEX

DigiBore Product Overview



DigiBore VERSATILE FINE BORING

Advanced versatile technology.

The Wohlhaupter® DigiBore boring head provides internal balancing, which makes this tool the stress-free choice to meet your required surface finish. Its digital display allows for quick and accurate diameter corrections at the machine.

Engineered with the *future in mind*.

- Diameter range: 3.00 mm - 208.00 mm
- Offers outside turning capabilities: 4.00 mm - 114.00 mm
- Digital readout for simple 0.002 mm diameter adjustments
- Ease the stress of working on different day-to-day projects with boring kits
- Automatic internal balancing improves surface finish, tool life, and accuracy
- Max spindle speed: 16,000 RPM
- Max coolant pressure: 40 bar



NOTE: Adjustment accuracy of 0.002 mm on diameter

IMPORTANT: Max spindle speed refers to maximum possible speed for an individual boring head and is not a recommended parameter. Refer to page B10-M: 12 for recommended application-specific parameters. Factory technical assistance is available for your specific applications through our Application Engineering department.
email: engineering.eu@alliedmachine.com

DIGI BORE



DigiBore Head

NOTE: Adjustment accuracy of 0.002 mm on diameter

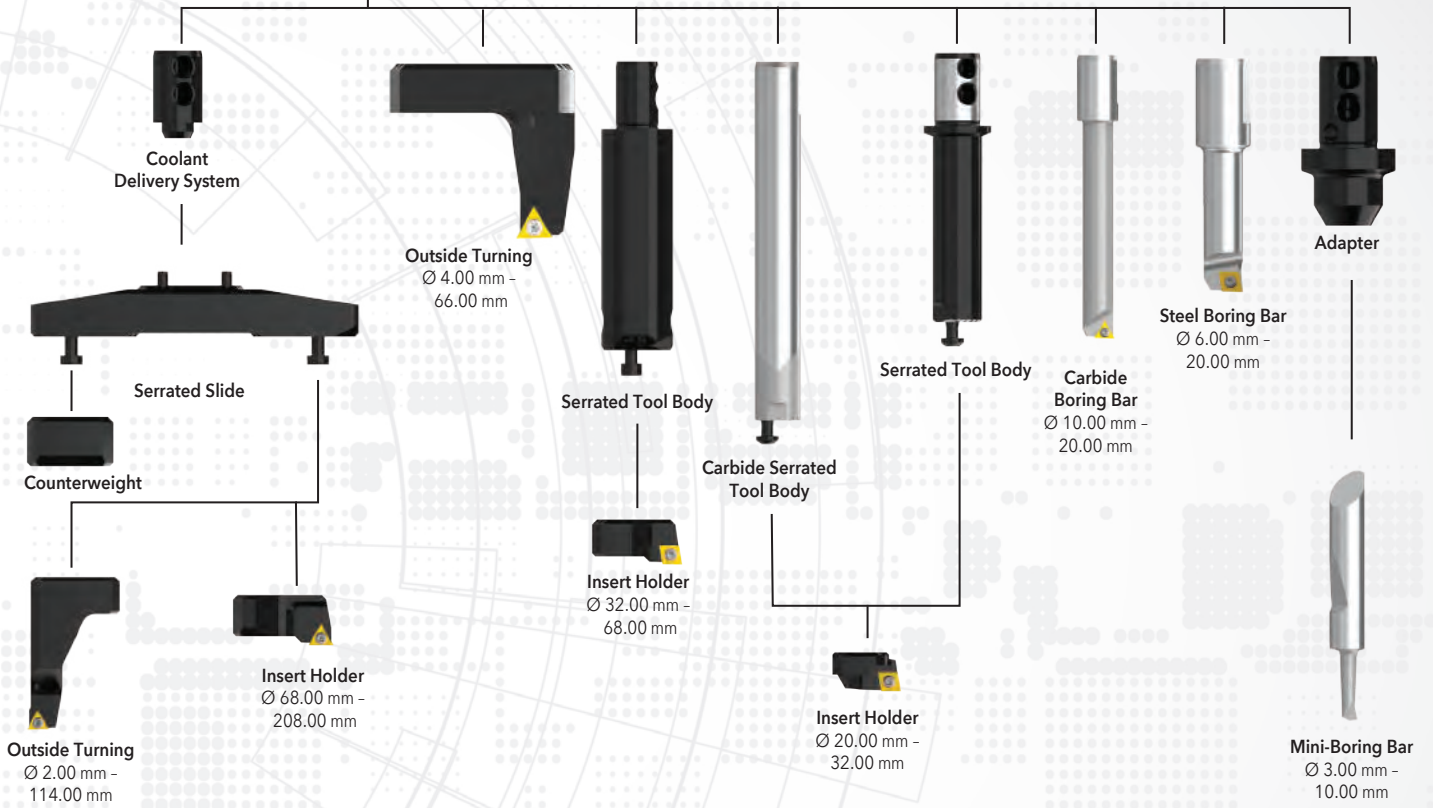

OPERATION **VERSATILITY**

from **3.00 mm** to **208.00 mm**
plus outside turning

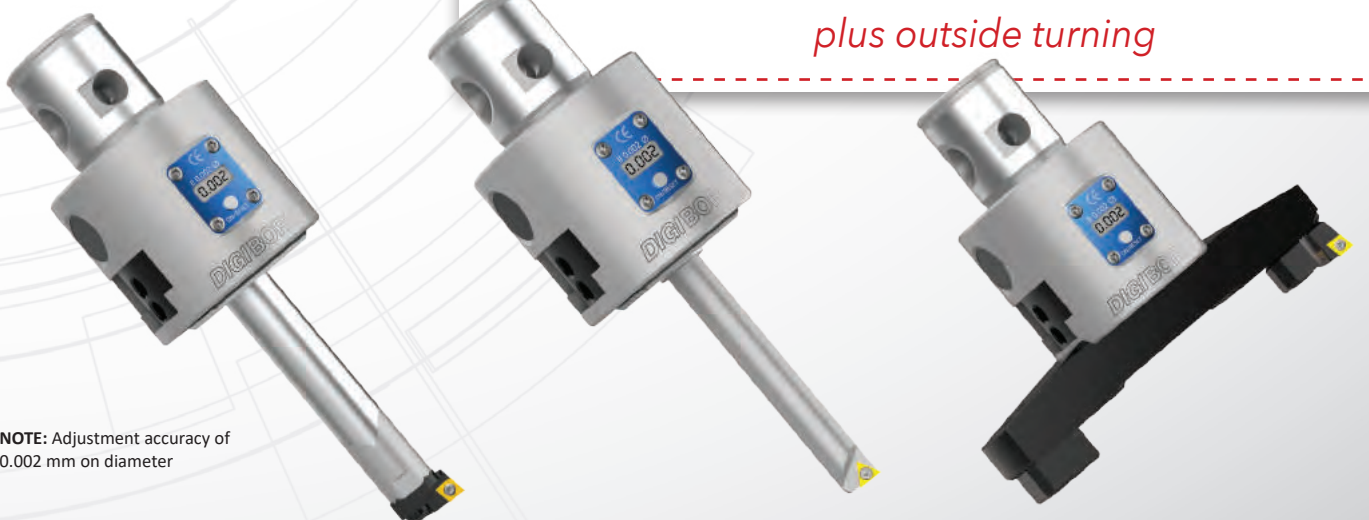

NOTE: Adjustment accuracy of 0.002 mm on diameter

Boring Heads

Diameter Range: 3.00 mm - 208.00 mm

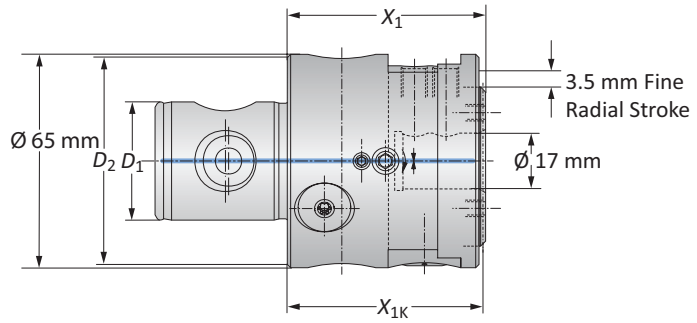

NOTE: Adjustment accuracy of 0.002 mm on diameter

DigiBore Boring Heads

MVS Connection	Boring Range	Boring Head		Weight	Part No.
		X_1	X_{1K}		
$D_2 D_1$					
50 - 28	3.00 - 208.00	60.00	59.50	1.30 (kg)	501005
63 - 36	3.00 - 208.00	60.00	59.50	1.50 (kg)	501001

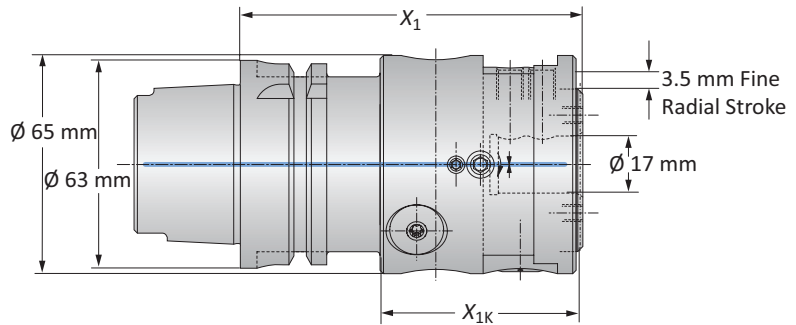

NOTE: Adjustment accuracy of 0.002 mm on diameter

DigiBore Boring Heads

Connection	Boring Range	Boring Head		Weight	Part No.
		X_1	X_{1K}		
HSK-A 63	3.00 - 208.00	102.00	59.50	2.10 (kg)	501004
PSC 63 (Polygon Shank)	3.00 - 208.00	102.00	59.50	2.10 (kg)	501019

B10-M: 12-13

B10-F

B10: VI-VII

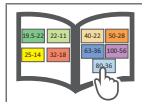
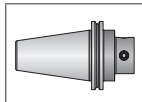
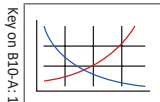

Ⓜ = Metric (mm)

IMPORTANT: Max spindle speed refers to maximum possible speed for an individual boring head and is not a recommended parameter. Refer to page B10-M: 12 for recommended application-specific parameters. Factory technical assistance is available for your specific applications through our Application Engineering department.
email: engineering.eu@alliedmachine.com

Mini Boring Bars

WHC05 | WHW04 | WBN150 | Diameter Range: 3.00 mm - 10.00 mm

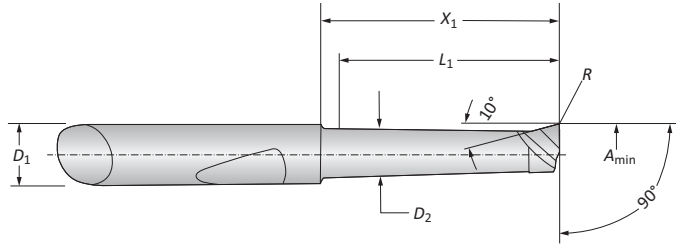

Mini Boring Bars

Boring Range	Boring Bar						Part No.		
	A_{min}	D_1	D_2	X_1	L_1	R	Coated Carbide	Uncoated Carbide	CBN
m	3.00	6.00	2.60	11.50	10.00	0.10	081306WHC05	-	081322WBN150
	3.00	6.00	2.60	16.50	15.00	0.10	081307WHC05	081307WHW04	-
	4.00	6.00	3.60	12.00	10.00	0.20	081308WHC05	-	081317WBN150
	4.00	6.00	3.60	17.00	15.00	0.20	081309WHC05	-	081341WBN150
	4.00	6.00	3.60	22.00	20.00	0.20	081310WHC05	081310WHW04	-
	5.00	6.00	4.60	12.00	10.00	0.20	081311WHC05	-	081318WBN150
	5.00	6.00	4.60	22.00	20.00	0.20	081312WHC05	-	081319WBN150
	5.00	6.00	4.60	32.00	30.00	0.20	081313WHC05	081313WHW04	-
	6.00	6.00	5.60	22.00	20.00	0.20	081314WHC05	-	081320WBN150
	6.00	6.00	5.60	32.00	30.00	0.20	081315WHC05	-	081321WBN150
	6.00	6.00	5.60	42.00	40.00	0.20	081316WHC05	081316WHW04	-
	8.00	8.00	7.60	25.00	23.00	0.20	081323WHC05	-	-
	8.00	8.00	7.60	50.00	48.00	0.20	081324WHC05	-	-



Adapters

Boring Range	Adapter					Weight	Part No.
	A_{min}	X_1	L_1	D_3	D_5		
m	3.00 - 8.00	22.50	14.00	6.00	20.00	0.04 (kg)	501050
	8.00 - 10.00	22.50	14.00	8.00	22.00	0.04 (kg)	501051

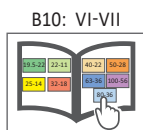
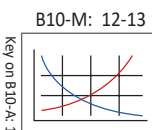
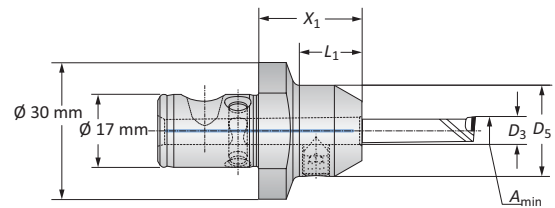

m = Metric (mm)

Boring Bars

Steel | Diameter Range: 6.00 mm - 20.00 mm



Form 101

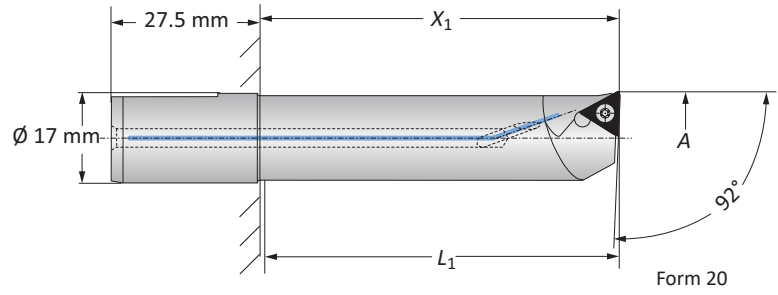

Form 20

Boring Range	Boring Bar		Weight	Insert Form	Part No.	Insert Form	Part No.
	A	X ₁					
6.00 - 8.00	22.00	19.00	0.05 (kg)	211*	502068	–	–
8.00 - 10.00	30.00	27.00	0.05 (kg)	211*	502066	–	–
10.00 - 11.00	30.00	27.00	0.06 (kg)	101	502012	20*	502001
11.00 - 12.00	30.00	27.00	0.06 (kg)	101	502075	20*	502070
12.00 - 13.00	45.00	42.00	0.07 (kg)	101	502013	20*	502002
13.00 - 14.00	45.00	42.00	0.08 (kg)	101	502076	20*	502071
14.00 - 15.00	50.00	47.00	0.08 (kg)	101	502014	20*	502003
15.00 - 16.00	50.00	47.00	0.09 (kg)	101	502077	20*	502072
16.00 - 17.00	60.00	57.00	0.10 (kg)	101	502015	20*	502004
17.00 - 18.00	60.00	57.00	0.12 (kg)	101	502078	20*	502073
18.00 - 19.00	68.00	65.00	0.13 (kg)	101	502016	20*	502005
19.00 - 20.00	68.00	65.00	0.14 (kg)	101	502079	20*	502074

*Not suitable for indexable inserts with a radius of 0.80 mm

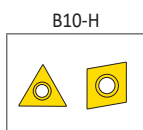
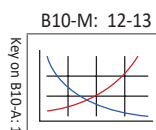

Boring Bars

Carbide | Diameter Range: 10.00 mm - 20.00 mm



Form 101

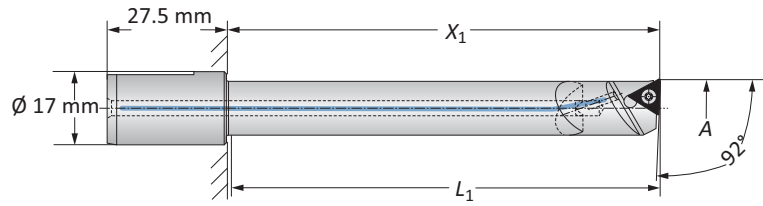

Form 20

Boring Range	Boring Bar		Weight	Insert Form	Part No.	Insert Form	Part No.	
	A	X ₁						L ₁
m	10.00 - 12.00	55.00	52.00	0.12 (kg)	101	502093	20*	502088
	10.00 - 12.00	70.00	67.00	0.14 (kg)	101	502034	20*	502023
	12.00 - 14.00	65.00	62.00	0.13 (kg)	101	502094	20*	502089
	12.00 - 14.00	85.00	82.00	0.18 (kg)	101	502035	20*	502024
	14.00 - 16.00	75.00	72.00	0.17 (kg)	101	502095	20*	502090
	14.00 - 16.00	90.00	87.00	0.22 (kg)	101	502036	20*	502025
	16.00 - 18.00	85.00	82.00	0.26 (kg)	101	502096	20*	502091
	16.00 - 18.00	110.00	107.00	0.32 (kg)	101	502037	20*	502026
	18.00 - 20.00	95.00	92.00	0.28 (kg)	101	502097	20*	502092
	18.00 - 20.00	120.00	117.00	0.40 (kg)	101	502038	20*	502027

*Not suitable for indexable inserts with a radius of 0.80 mm

Key on B10-A: 1

B10-M: 12-13

B10-H

B10: VI-VII

m = Metric (mm)
Inserts sold separately

Serrated Tool Bodies | Insert Holders

Steel | Carbide | Diameter Range: 20.00 mm - 32.00 mm

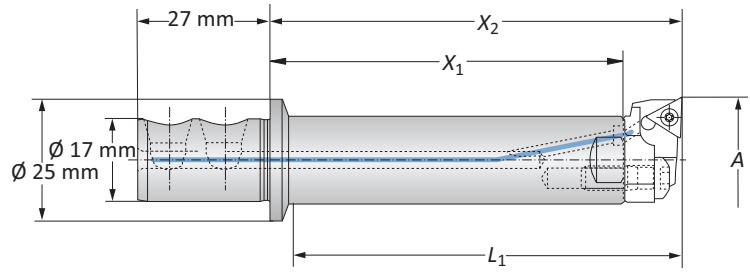

Steel Serrated Tool Body

Boring Range	Serrated Tool Body			Weight	Part No.
A	X ₁	X ₂	L ₁		
20.00 - 32.00	72.00	84.00	77.00	0.20 (kg)	502045

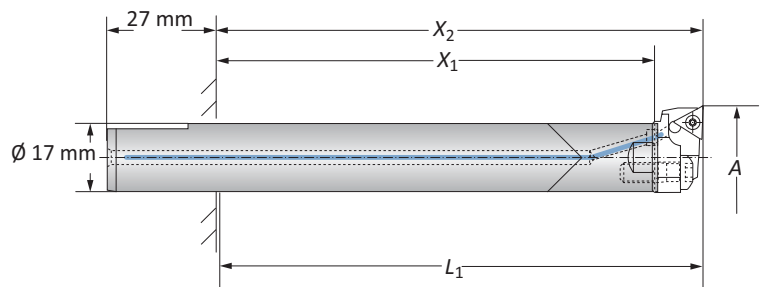

Carbide Serrated Tool Body

Boring Range	Serrated Tool Body			Weight	Part No.
A	X ₁	X ₂	L ₁		
20.00 - 32.00	108.00	120.00	117.00	0.40 (kg)	502062

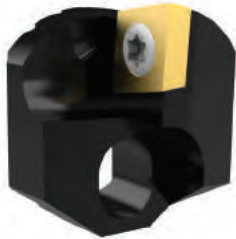

Form 101

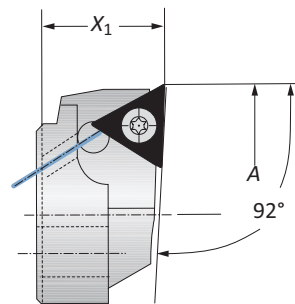

Form 20

Insert Holders

Boring Range	Insert Holder	Weight	Insert Form	Part No.	Insert Form	Part No.
A	X ₁					
20.00 - 22.00	12.00	0.01 (kg)	101	502052	20*	502046
22.00 - 24.00	12.00	0.01 (kg)	101	502053	20*	502047
24.00 - 26.00	12.00	0.01 (kg)	101	502054	20*	502048
26.00 - 28.00	12.00	0.01 (kg)	101	502055	20*	502049
28.00 - 30.00	12.00	0.01 (kg)	101	502056	20*	502050
30.00 - 32.00	12.00	0.01 (kg)	101	502057	20*	502051

*Not suitable for indexable inserts with a radius of 0.80 mm

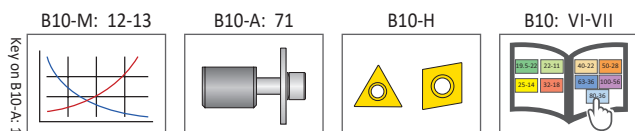

m = Metric (mm)
Inserts sold separately

Alu-Line Serrated Tool Bodies | Insert Holders

Diameter Range: 32.00 mm - 68.00 mm

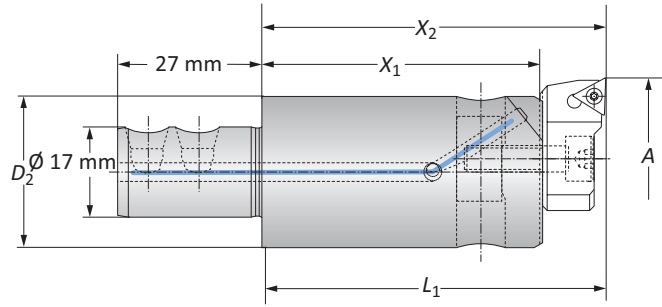

Alu-Line Serrated Tool Bodies

Boring Range	Serrated Tool Body					Weight	Part No.
	A	D ₂	X ₁	X ₂	L ₁		
m	32.00 - 50.00	28.50	52.00	66.00	63.00	0.10 (kg)	501052
	32.00 - 50.00	28.50	88.00	102.00	99.00	0.20 (kg)	501060
	50.00 - 68.00	46.00	61.00	75.00	72.00	0.20 (kg)	501053
	50.00 - 68.00	46.00	106.00	120.00	117.00	0.30 (kg)	501061



Form 101

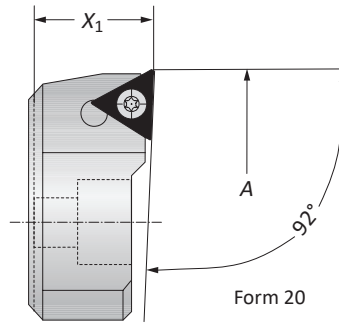

Form 20

Insert Holders

Serrated Tool Body	Boring Range	Insert Holder	Weight	Insert Form	Part No.	
	A	X ₁				
m	501052 / 501060	32.00 - 41.00	14.00	0.03 (kg)	20*	502060
		41.00 - 50.00	14.00	0.04 (kg)	20*	502061
	501053 / 501061	32.00 - 41.00	14.00	0.03 (kg)	101	502058
			41.00 - 50.00	14.00	0.04 (kg)	101
50.00 - 59.00		14.00	0.03 (kg)	20*	502060	
		59.00 - 68.00	14.00	0.04 (kg)	20*	502061
50.00 - 59.00	14.00	0.03 (kg)	101	502058		
	59.00 - 68.00	14.00	0.04 (kg)	101	502059	

*Not suitable for indexable inserts with a radius of 0.80 mm

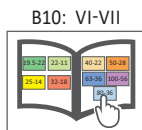
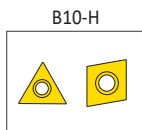
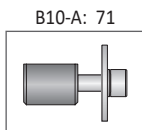
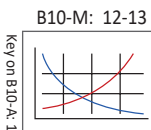

Key on B10-A: 1

m = Metric (mm)
Inserts sold separately

Alu-Line Serrated Slides | Insert Holders

Diameter Range: 68.00 mm - 208.00 mm

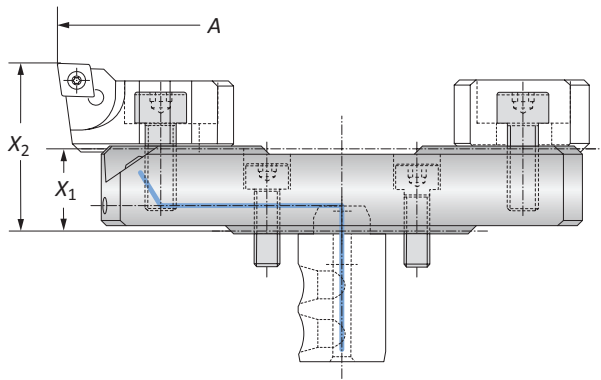

Alu-Line Serrated Slides

Boring Range	Serrated Slide		Weight	Part No.
	A	X ₁		
68.00 - 96.00	16.00	32.50	0.10 (kg)	501054
96.00 - 124.00	16.00	32.50	0.10 (kg)	501055
124.00 - 152.00	16.00	32.50	0.20 (kg)	501056
152.00 - 180.00	22.00	38.50	0.25 (kg)	501058
180.00 - 208.00	22.00	38.50	0.30 (kg)	501059

Insert Holders

Boring Range	Weight	Insert Form	Part No.
68.00 - 208.00	0.05 (kg)	101	502064
68.00 - 208.00	0.05 (kg)	20	502069

NOTE: Other insert holders available upon request



Form 20

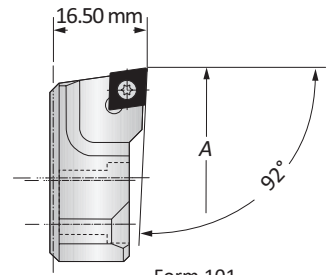

Form 101

Counterweight

Counterweight	Weight	Part No.
X ₁		
13.40	0.05 (kg)	502165

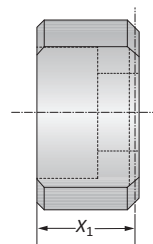

Coolant Delivery System

Coolant Delivery System	Part No.
Weight	
0.02 (kg)	501157

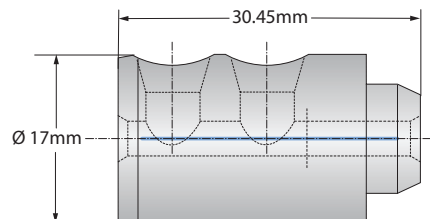

B10-M: 12-13

B10-A: 71

B10-H

B10: VI-VII

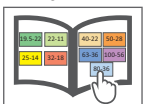
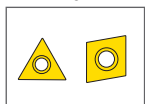
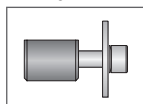
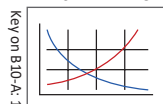

Ⓜ = Metric (mm)
Inserts sold separately

Outside Turning Insert Holders for Boring Heads

Diameter Range: 4.00 mm - 66.00 mm

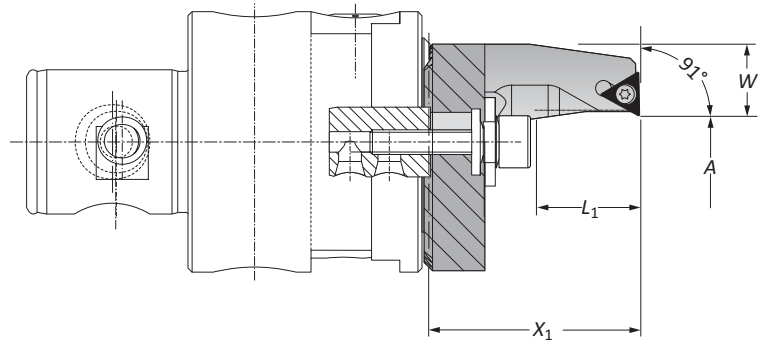

Type A Insert Holders | Diameter Range: 4.00 mm - 30.00 mm

	Boring Range		Insert Holder			Weight	Insert Form	Part No.
	A	X ₁	L ₁	W				
	4.00 - 17.50	40.50	20.00	16.60	0.10 (kg)	20*	236081	
	16.50 - 30.00	50.50	30.00	11.10	0.10 (kg)	20*	236082	

NOTE: Clockwise and neutral execution

*Not suitable for indexable inserts with a radius of 0.80 mm

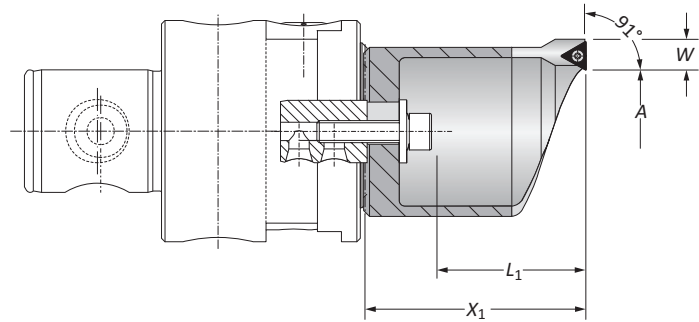

Type B Insert Holders | Diameter Range: 29.00 mm - 66.00 mm

	Boring Range		Insert Holder			Weight	Insert Form	Part No.
	A	X ₁	L ₁	W				
	29.00 - 44.00	75.50	54.00	9.60	0.30 (kg)	20*	236083	
	43.00 - 66.00	100.50	79.00	9.60	0.40 (kg)	20*	236084	

NOTE: Clockwise and neutral execution

*Not suitable for indexable inserts with a radius of 0.80 mm

Clamping Pieces for Outside Turning Insert Holders

Insert Holder Type	Boring Range	Service Key	Complete Part No.
	A	s5	502080
	B	s5	502081

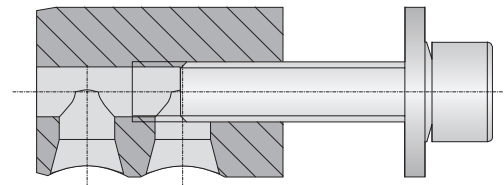



B10-M: 12-13

B10-A: 71

B10-H

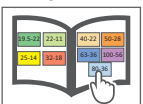
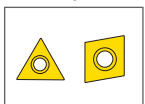
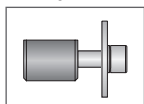
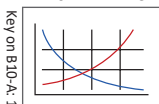
B10: VI-VII



 = Metric (mm)
Inserts sold separately

Outside Turning Serrated Slides | Insert Holders

Diameter Range: 2.00 mm - 114.00 mm

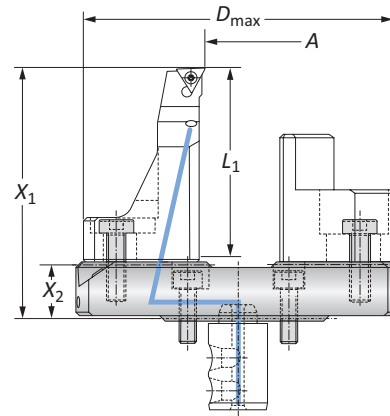
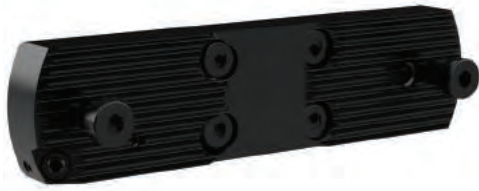

Outside Turning Serrated Slides

	Boring Range		Serrated Slide				Weight	Part No.
	A	X ₁	X ₂	L ₁	D _{max}			
m	2.00 - 30.00	73.00	16.00	55.00	101.00	0.35 (kg)	501064	
	30.00 - 58.00	73.00	16.00	55.00	129.00	0.44 (kg)	501065	
	58.00 - 86.00	79.00	22.00	55.00	157.00	0.60 (kg)	501066	
	86.00 - 114.00	79.00	22.00	55.00	185.00	0.73 (kg)	501067	



Outside Turning Insert Holder

	Outside Turning Range		Insert Holder		Part No.
	A	X ₁	Weight	Insert Form	
m	2.00 - 114.00	57.00	0.15 (kg)	20	502082

NOTE: Clockwise and neutral execution

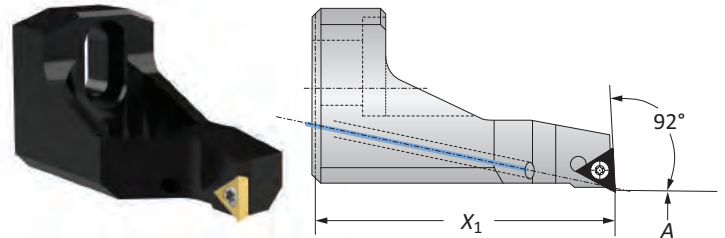

Counterweight

	Counterweight		Part No.
	X ₁	Weight	
m	37.75	0.16 (kg)	502183

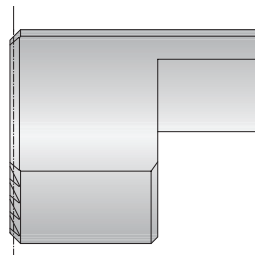

Coolant Delivery System

	Coolant Delivery System	
	Weight	Part No.
m	0.02 (kg)	501157

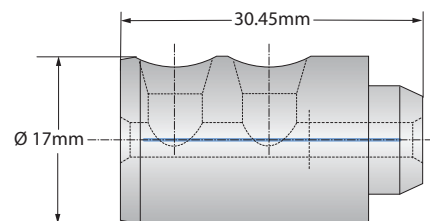

Key on B10-A: 1

B10-M: 12-13

B10-A: 71

B10-H

B10: VI-VII

m = Metric (mm)
Inserts sold separately

Accessories

No.	Part	Size	Part No.
1	Set screw	s3	415244
2	Screw for securing insert holder	T25	415112
3	Clamping piece	-	145184
4	Cap screw for securing insert holders	s4	027154
5	Cap screw for securing insert holder/counterweight	s4	315248
6	Set screw - coolant	501054, 501055, 501056	s1.5 114224
		501058, 501059	s1.5 115303
7	Cap screw for securing serrated slide	s4	115166
8	Sealing ring for coolant delivery	-	415386

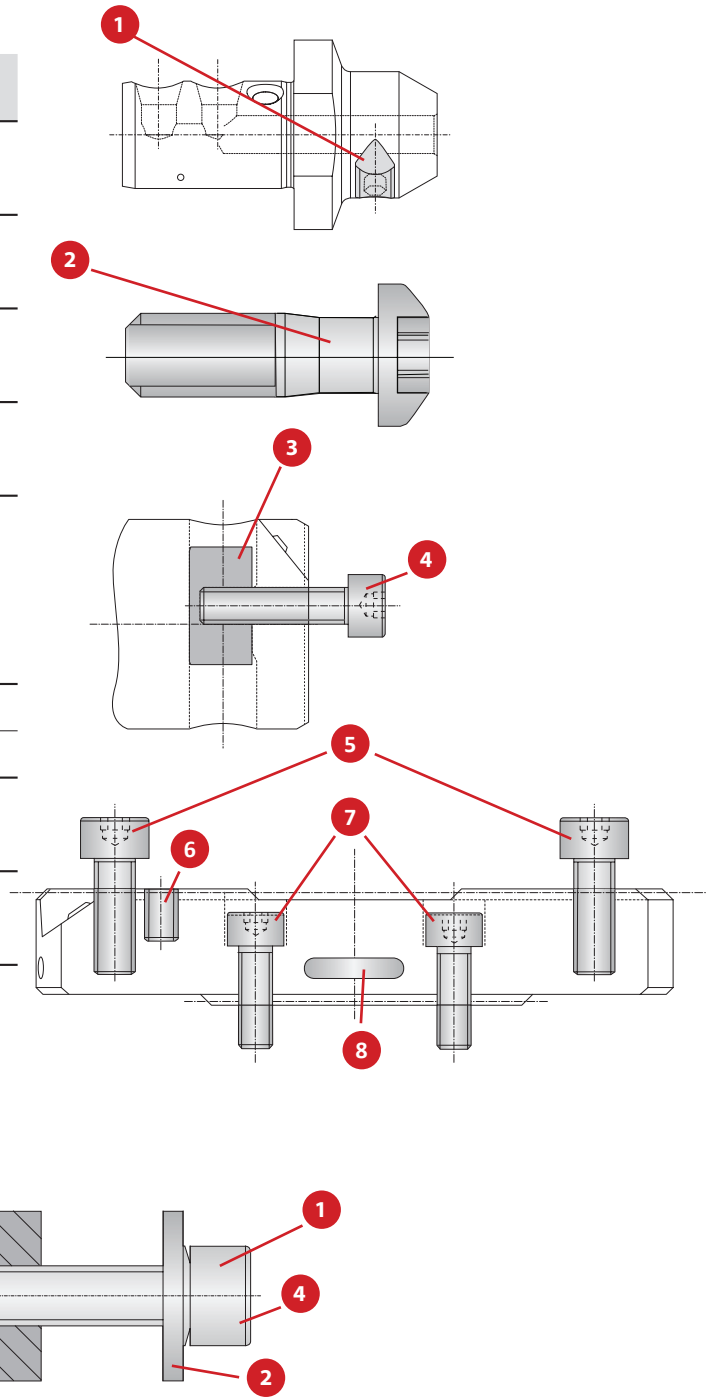

Boring Range	Type	Hex Size	Clamping Screw Parts				Complete Part No.
			1 Cap Screw	2 Washer	3 Clamping Piece	4 Locking Washer	
m 4.00 - 30.00	A	s5	070153	315155	502180	215254	502080
	B	s5	070153	315156	502180	215254	502081

Accessories

No.	Part	Insert Form	Size	Part No.
1	Clamping screw	-	-	415353
2	Set screw for clamping tool	-	-	215674
3	Battery cover	-	-	415895
4	Battery*	-	-	415896
5	Battery access cover with sealing ring	-	-	501016
6	Insert screws	Form 211 Form 20 Form 101	T6 T7 T8	215377 115535 115676
7	Hex driver	-	s1.5 s3	215472 115630
8	Hex driver	-	s4	115576
9	Torx® driver	-	T6 T7 T8 T20	115537 115591 115590 215150
10	Torque screwdriver, Torx	(0.6 Nm) Form 211 (0.9 Nm) Form 20 (1.2 Nm) Form 101	T6 T7 T8	415507 415508 415514

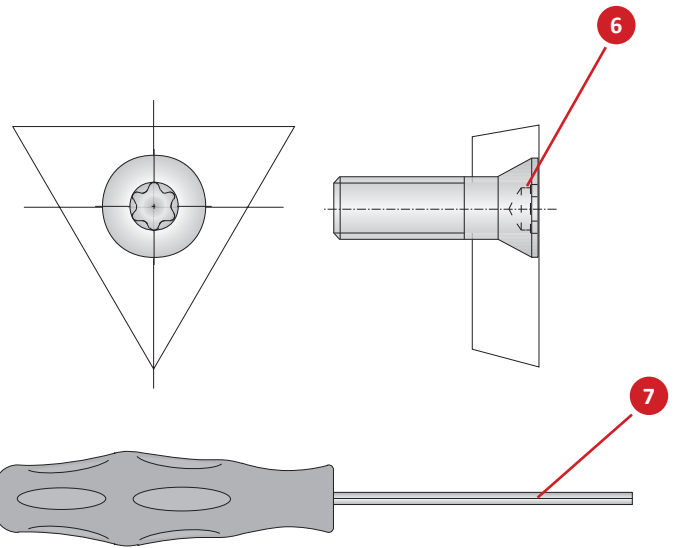
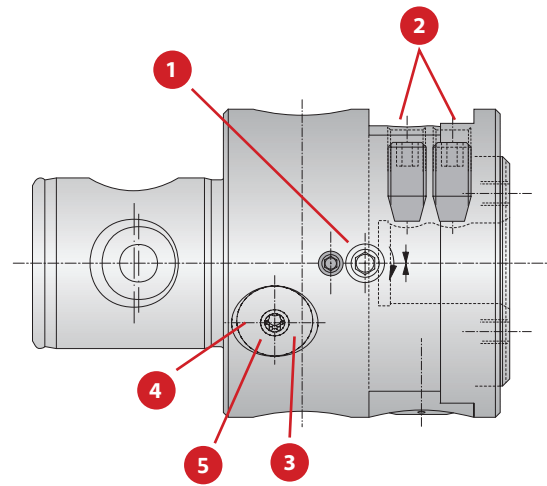

*Always change two batteries

NOTE: Please use VARTA batteries (V392 SR41)

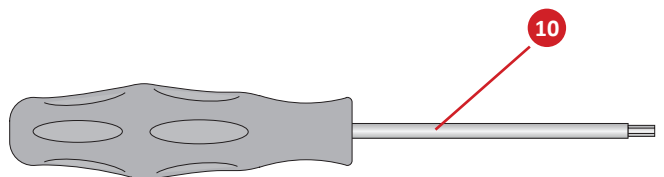
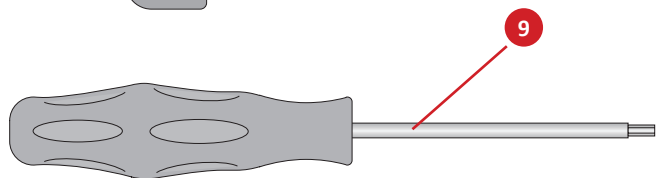
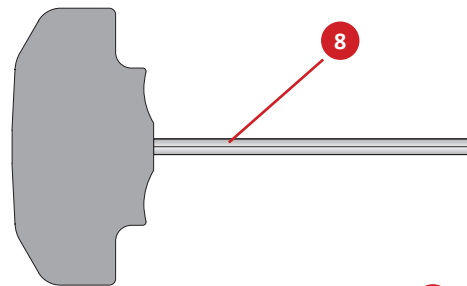

Kit Components

Insert Form 101 | Diameter Range: 10.00 mm - 32.00 mm

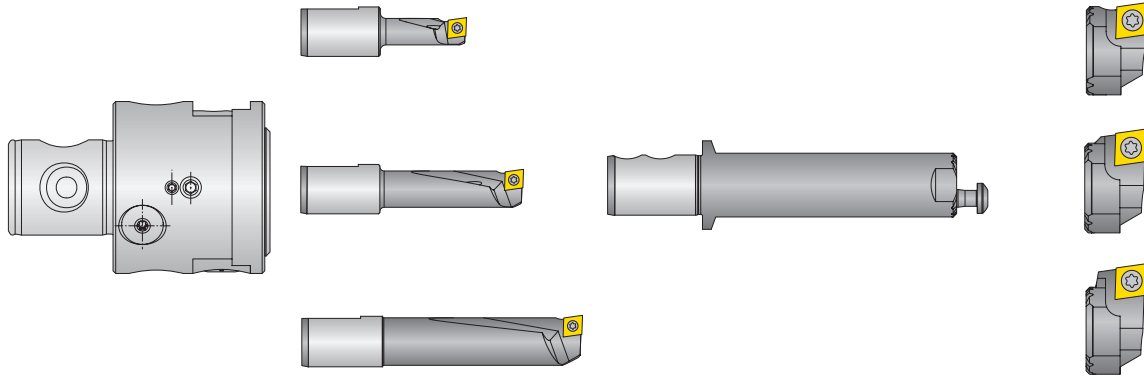

Diameter Range: 10.00 mm - 32.00 mm

		Kit Components						
	Boring Head	Boring Range	Boring Bars	Boring Range	Serrated Tool Body	Insert Holders	Service Keys	Kit No.
	501001	10.00 - 11.00 14.00 - 15.00 18.00 - 19.00	502012 502014 502016	20.00 - 32.00	502045	502052 502054 502056	115576 (s4) 415121 (T25) 115590 (T8)	103061

NOTE: Inserts sold separately



Key on B10-A-1

B10-M: 12-13

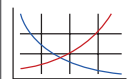

B10-H

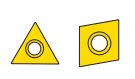

B10: VI-VII

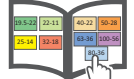

 = Metric (mm)
Inserts sold separately

IMPORTANT: Max spindle speed refers to maximum possible speed for an individual boring head and is not a recommended parameter. Refer to page B10-M: 12 for recommended application-specific parameters. Factory technical assistance is available for your specific applications through our Application Engineering department.
email: engineering.eu@alliedmachine.com

Kit Components

Insert Form 20 | Diameter Range: 10.00 mm - 32.00 mm

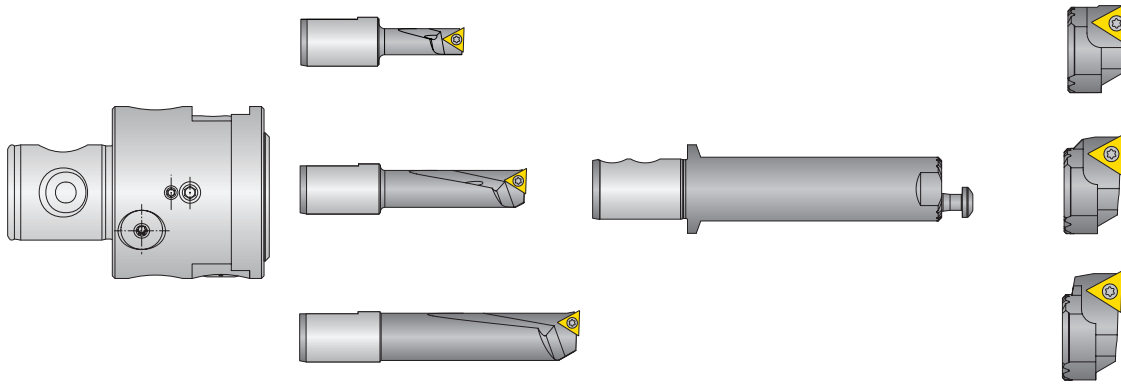

Diameter Range: 10.00 mm - 32.00 mm

		Kit Components						
	Boring Head	Boring Range	Boring Bars	Boring Range	Serrated Tool Body	Insert Holders	Service Keys	Kit No.
m	501001	10.00 - 11.00	502001	20.00 - 32.00	502045	502046	115576 (s4)	103062
		14.00 - 15.00	502003			502048	415121 (T25)	
		18.00 - 19.00	502005			502050	115591 (T7)	

NOTE: Inserts sold separately



Key on B10-A-1

B10-M: 12-13

B10-H

B10: VI-VII

m = Metric (mm)

Inserts sold separately

IMPORTANT: Max spindle speed refers to maximum possible speed for an individual boring head and is not a recommended parameter. Refer to page B10-M: 12 for recommended application-specific parameters. Factory technical assistance is available for your specific applications through our Application Engineering department.
 email: engineering.eu@alliedmachine.com

Kit Components

Insert Form 101 | Diameter Range: 32.00 mm - 68.00 mm

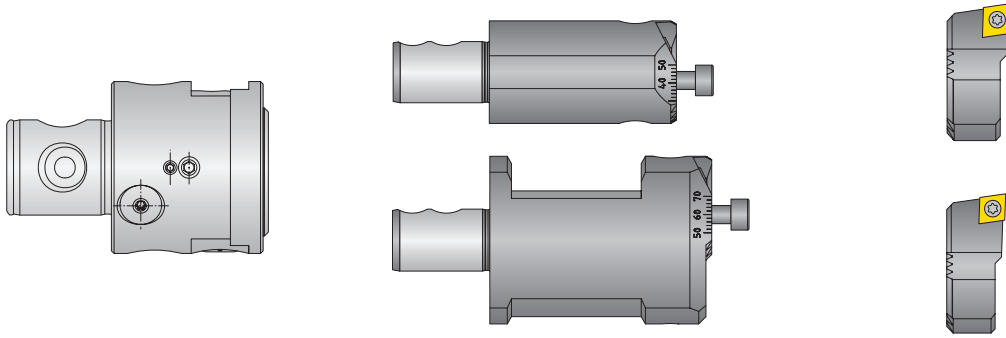

Diameter Range: 32.00 mm - 68.00 mm

	Boring Head	Kit Components				Kit No.
		Boring Range	Serrated Tool Body	Insert Holders	Service Keys	
Ⓜ	501001	32.00 - 50.00	501052	502058	115576 (s4)	103063
		50.00 - 68.00	501053	502059	115590 (T8)	

NOTE: Inserts sold separately



Key on B10-A-1

B10-M: 12-13

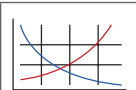

B10-H

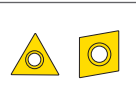

B10: VI-VII

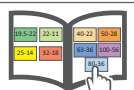

Ⓜ = Metric (mm)
Inserts sold separately

IMPORTANT: Max spindle speed refers to maximum possible speed for an individual boring head and is not a recommended parameter. Refer to page B10-M: 12 for recommended application-specific parameters. Factory technical assistance is available for your specific applications through our Application Engineering department.
email: engineering.eu@alliedmachine.com

Kit Components

Insert Form 20 | Diameter Range: 32.00 mm - 68.00 mm

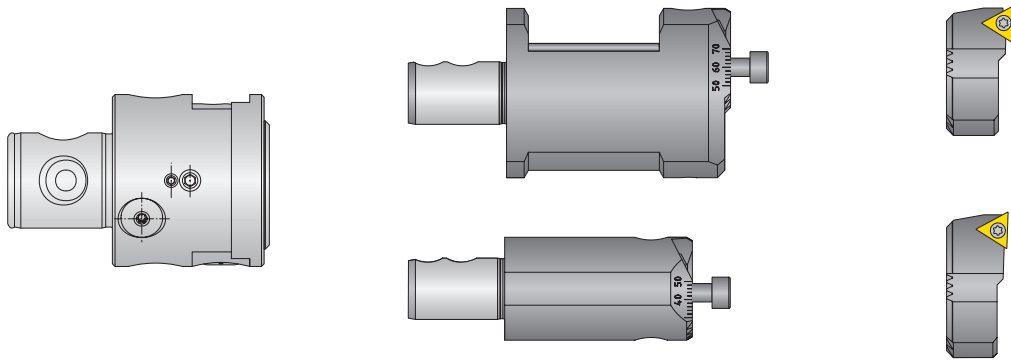

Diameter Range: 32.00 mm - 68.00 mm

	Kit Components					Kit No.
	Boring Head	Boring Range	Serrated Tool Body	Insert Holders	Service Keys	
m	501001	32.00 - 50.00 50.00 - 68.00	501052 501053	502060 502061	115576 (s4) 115591 (T7)	103064

NOTE: Inserts sold separately



B10-M: 12-13

B10-H

B10: VI-VII

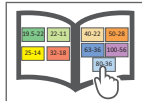
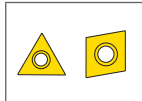
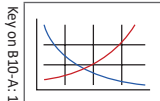

m = Metric (mm)

Inserts sold separately

IMPORTANT: Max spindle speed refers to maximum possible speed for an individual boring head and is not a recommended parameter. Refer to page B10-M: 12 for recommended application-specific parameters. Factory technical assistance is available for your specific applications through our Application Engineering department.
 email: engineering.eu@alliedmachine.com

Kit Components

Insert Form 101 | Diameter Range: 68.00 mm - 152.00 mm

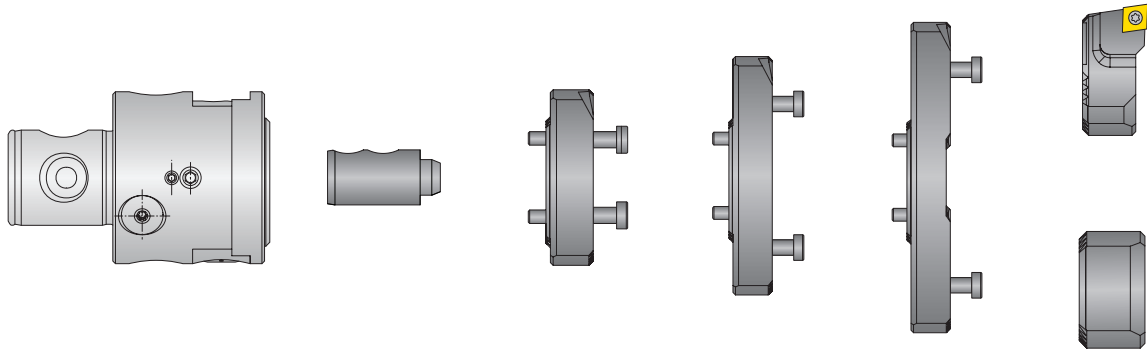

Diameter Range: 68.00 mm - 152.00 mm

		Kit Components						
	Boring Head	Boring Range	Serrated Slides	Insert Holder	Counterweight	Coolant Delivery	Service Keys	Kit No.
	501001	68.00 - 96.00 96.00 - 124.00 124.00 - 152.00	501054 501055 501056	502064	502165	501157	115576 (s4) 115590 (T8)	103065

NOTE: Inserts sold separately



Key on B10-A-1

B10-M: 12-13

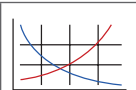

B10-H

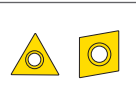

B10: VI-VII

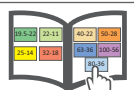

 = Metric (mm)
Inserts sold separately

IMPORTANT: Max spindle speed refers to maximum possible speed for an individual boring head and is not a recommended parameter. Refer to page B10-M: 12 for recommended application-specific parameters. Factory technical assistance is available for your specific applications through our Application Engineering department.
email: engineering.eu@alliedmachine.com

Kit Components

Insert Form 20 | Diameter Range: 68.00 mm - 152.00 mm

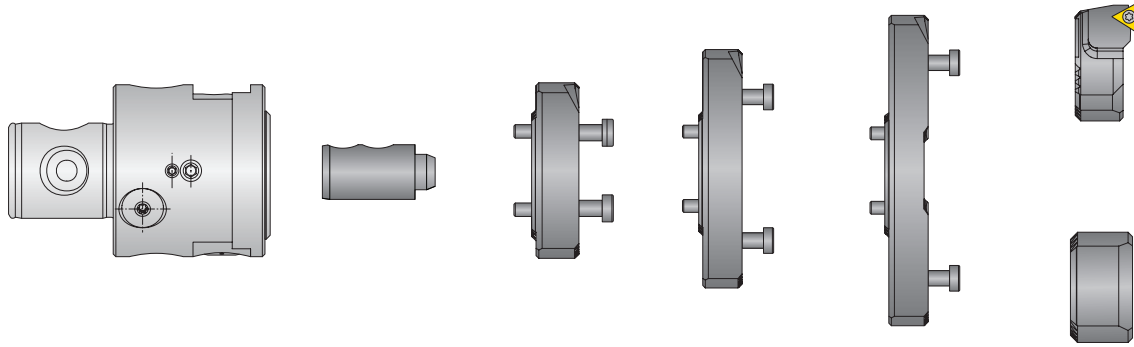

Diameter Range: 68.00 mm - 152.00 mm

		Kit Components						
	Boring Head	Boring Range	Serrated Slides	Insert Holder	Counterweight	Coolant Delivery	Service Keys	Kit No.
Ⓜ	501001	68.00 - 96.00	501054	502069	502165	501157	115576 (s4)	103066
		96.00 - 124.00	501055				115591 (T7)	
		124.00 - 152.00	501056					

NOTE: Inserts sold separately



B10-M: 12-13

B10-H

B10: VI-VII

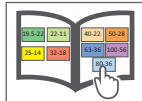
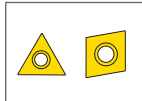
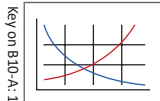

Ⓜ = Metric (mm)

Inserts sold separately

IMPORTANT: Max spindle speed refers to maximum possible speed for an individual boring head and is not a recommended parameter. Refer to page B10-M: 12 for recommended application-specific parameters. Factory technical assistance is available for your specific applications through our Application Engineering department.
 email: engineering.eu@alliedmachine.com

Kit Components

Insert Form 101 | Diameter Range: 96.00 mm - 208.00 mm

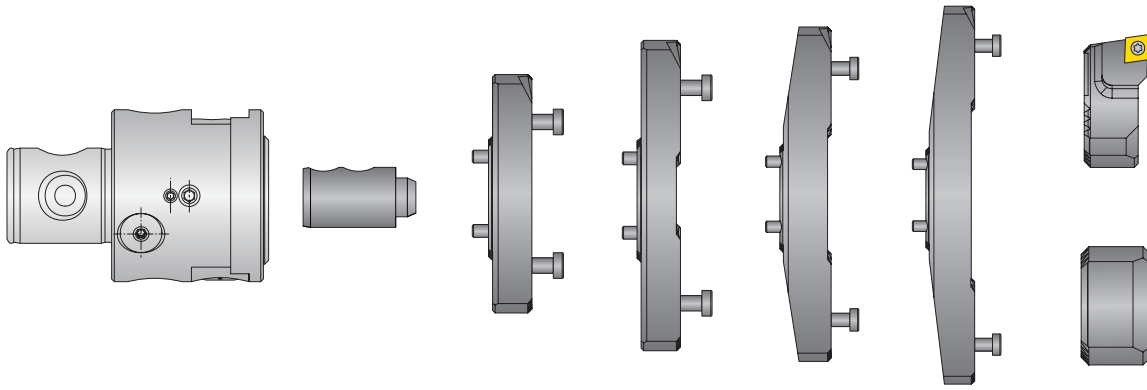

Diameter Range: 96.00 mm - 208.00 mm

		Kit Components						
	Boring Head	Boring Range	Serrated Slides	Insert Holder	Counterweight	Coolant Delivery	Service Keys	Kit No.
m	501001	96.00 - 124.00	501055	502064	502165	501157	115576 (s4) 115590 (T8)	103081
		124.00 - 152.00	501056					
		152.00 - 180.00	501058					
		180.00 - 208.00	501059					

NOTE: Inserts sold separately



Key on B10-A-1

B10-M: 12-13

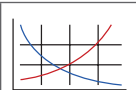

B10-H

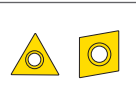

B10: VI-VII

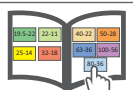

m = Metric (mm)
Inserts sold separately

IMPORTANT: Max spindle speed refers to maximum possible speed for an individual boring head and is not a recommended parameter. Refer to page B10-M: 12 for recommended application-specific parameters. Factory technical assistance is available for your specific applications through our Application Engineering department.
email: engineering.eu@alliedmachine.com

Kit Components

Insert Form 20 | Diameter Range: 96.00 mm - 208.00 mm

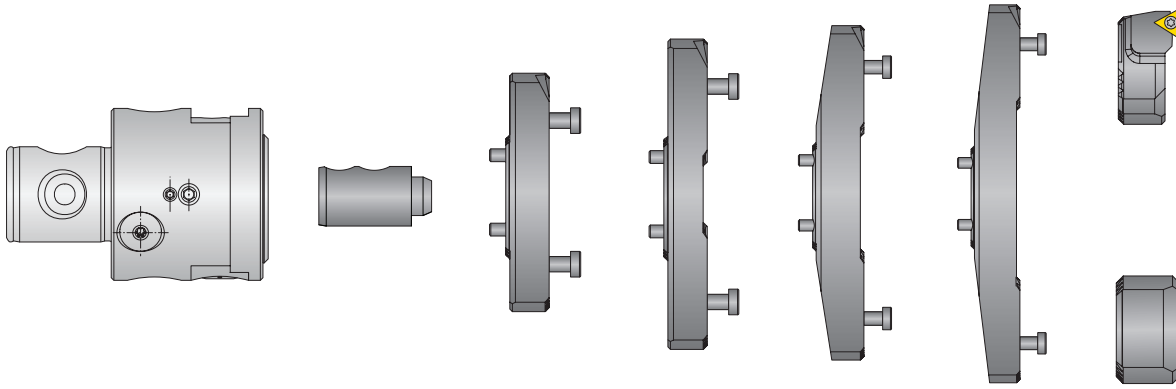

Diameter Range: 96.00 mm - 208.00 mm

		Kit Components						
	Boring Head	Boring Range	Serrated Slides	Insert Holder	Counterweight	Coolant Delivery	Service Keys	Kit No.
m	501001	96.00 - 124.00	501055	502069	502165	501157	115576 (s4)	103080
		124.00 - 152.00	501056				115591 (T7)	
		152.00 - 180.00	501058					
		180.00 - 208.00	501059					

NOTE: Inserts sold separately



B10-M: 12-13

B10-H

B10: VI-VII

Key on B10-A-1

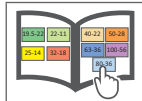
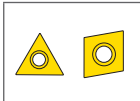
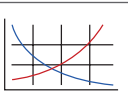

m = Metric (mm)

Inserts sold separately

IMPORTANT: Max spindle speed refers to maximum possible speed for an individual boring head and is not a recommended parameter. Refer to page B10-M: 12 for recommended application-specific parameters. Factory technical assistance is available for your specific applications through our Application Engineering department.
 email: engineering.eu@alliedmachine.com

SECTION

B10-B

Fine Boring

Wohlhaupter® Fine Boring

410 | 464 | 364 | 564 | 310 | 537

► Diameter Range: 20.00 mm - 205.00 mm



NOTE: Metric items pictured

NOTE: 3E^{TECH+} adjustment accuracy of 0.001 mm on diameter

NOTE: Digital and vernier adjustment accuracy of 0.002 mm on diameter

Boring has never been more exciting.

Wohlhaupter's fine boring systems are offered in both vernier and easy-to-read digital readout boring heads and cassettes. The lightweight Alu-Line serrated tool bodies reduce weight on the machine spindle.

Unbalanced & Balanced Digital 3E^{TECH+} Boring Heads

- 410 / 464 fine boring heads
- 410 Ø 20.00 mm - 29.00 mm
- 464 Ø 29.00 mm - 205.00 mm

Balanced Analogue Boring Heads

- 364 / 464 fine boring heads
- 364 Ø 20.00 mm - 29.50 mm
- 464 Ø 29.00 mm - 205.00 mm

Balanced Digital Boring Heads

- 564 fine boring heads
- Ø 50.00 mm - 205.00 mm

Unbalanced Analogue Boring Heads

- 310 fine boring heads
- Ø 20.00 mm - 205.00 mm

Analogue and Digital Cassettes

- 537 fine boring cassettes
- Ø 100.00 mm - 205.00 mm

Applicable Industries



Aerospace



Agriculture



Automotive



Firearms



General Machining



Oil & Gas



Renewable Energy

Your safety and the safety of others is very important. This catalogue contains important safety messages. Always read and follow all safety precautions.



This triangle is a safety hazard symbol. It alerts you to potential safety hazards that can cause tool failure and serious injury.

When you see this symbol in the catalogue, look for a related safety message that may be near this triangle or referred to in the nearby text.

There are safety signal words also used in the catalogue. Safety messages follow these words.

WARNING

WARNING (shown above) means that failure to follow the precautions in this message could result in tool failure and serious injury.

NOTICE means that failure to follow the precautions in this message could result in damage to the tool or machine but not result in personal injury.

NOTE and **IMPORTANT** are also used. These are important that you read and follow but are not safety-related.

Visit www.alliedmachine.com for the most up-to-date information and procedures.

Fine Boring Table of Contents

Reference Icons

The following icons will appear throughout the catalogue to help you navigate between products.

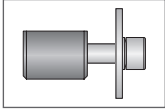

Clamping Elements

For use with insert holders and boring heads

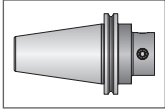

Shanks

A variety of shanks for different machines

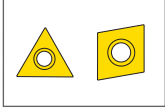

Inserts

For use with insert holder boring heads and boring bars using indexable inserts

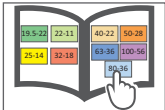

MVS Connection Colour Guide

Detailed instructions and information regarding the MVS connection(s)

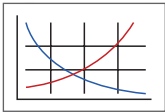

Recommended Cutting Data

Speed and feed recommendations for optimum and safe boring



Through Coolant Option

Indicates that the product is through coolant

Digital 3E^{TECH+} 410 / 464

Product Overview	2 - 3
Unbalanced 410 Boring Heads	4
Balanced 464 Boring Heads	5 - 6
Insert Holders	7
Accessories	8

Balanced Analogue 364 / 464

Product Overview	10 - 11
Boring Heads	12 - 13
Insert Holders	14
Accessories	15

Balanced Digital 564

Product Overview	16 - 17
Boring Heads	18 - 19
Insert Holders	20
Accessories	21

Unbalanced Analogue 310

Product Overview	22 - 23
Boring Heads	24 - 25
Serrated Shims Insert Holders	26
Accessories	27

537 Cassettes

Product Overview	28 - 29
Analogue Cassettes	30
3E ^{TECH+} Digital Cassettes	31
Serrated Tool Bodies Insert Holders	32
537 3E ^{TECH+} Accessories	33

Series	Diameter Range
	Metric (mm)
410	20.00 - 29.00
464	29.00 - 205.00
364	20.00 - 29.50
564	50.00 - 205.00
310	20.00 - 205.00
537	100.00 - 205.00

410 and 464 Product Overview



Digital 3E^{TECH+} 410 and 464 FINE BORING

Make easy diameter adjustments with our 3E^{TECH+} digital readout module.

Wohlhaupter® 410 and 464 digital boring heads are equipped with a 3E^{TECH+} docking port for easy digital adjustments. Boring heads from 29.00 mm offer precision boring with automatic balancing. Our boring heads are specifically engineered to minimise the residual imbalance produced by insert holder displacement. Wohlhaupter Alu-Line boring heads, ranging from 65.00 mm, offer a lightweight aluminium design with a wear-resistant coating that reduces weight on the spindle up to 50%. The insert holder can also be rotated for reverse machining jobs.

- Unbalanced 410 diameter range: 20.00 mm - 29.00 mm
- Balanced 464 diameter range: 29.00 mm - 205.00 mm
- Balanced 464 Alu-Line diameter range: 65.00 mm - 205.00 mm
 - Special coating on Alu-Line for wear-resistant surface
 - Alu-Line body reduces tool weight by 50%, reducing stress on the spindle
- Through coolant
- 3E^{TECH+} and vernier diameter adjustment of 0.002 mm
- Internal balancing improves tool life and surface finish
- Insert holder can be rotated for back boring jobs
- Max cutting speed: 1,700 M/min

Highly accurate adjustments through *vernier* scale



NOTE: 3E^{TECH+} adjustment accuracy of 0.001 mm on diameter

NOTE: Vernier adjustment accuracy of 0.002 mm on diameter

Versatile 3E^{TECH+} digital readout compatible with other boring tools

IMPORTANT: Max spindle speed refers to maximum possible speed for an individual boring head and is not a recommended parameter. Refer to page B10-M: 12 for recommended application-specific parameters. Factory technical assistance is available for your specific applications through our Application Engineering department.
email: engineering.eu@alliedmachine.com

WOHLHAUPTER® 410 and 464 3E^{TECH+} DIGITAL BORING HEADS

Wohlhaupter 3E^{TECH+}

Improve productivity and quality with the Wohlhaupter 3E^{TECH+} external digital readout module. The 3E^{TECH+} docks onto boring heads and cassettes that offer the 3E^{TECH+} port to make easy diameter adjustments at the machine.

- Make quick and easy micron-accurate diameter adjustments
- Easy-to-read digital display shows exact diameter adjustments
- Designed to be removed from boring tool before operation (if forgotten 3E^{TECH+} will fall off at 500 RPM)
- Adjustments of 0.002 mm on diameter
- Water and dust resistant IP 56
- Coolant and chip resistant
- 3E^{TECH+} will automatically turn off after 30 seconds of not using
- WEEE-Reg.-Nr. DE 15820388

✓ High-production fine boring

✓ Easy diameter adjustment with 3E^{TECH+}

✓ Self-balancing 464 boring heads

410 & 464 BORING HEADS WITH 3E ^{TECH+}	
Diameter Range	Part No.
20.00 - 24.50	410001
24.50 - 29.00	410002
29.00 - 38.00	464003
38.00 - 50.00	464004
50.00 - 65.50	464005
65.00 - 83.00	464006
82.00 - 103.00	464007
100.00 - 130.00	464008
125.00 - 167.50	464009
162.50 - 205.00	464010



NOTE: 3E^{TECH+} adjustment accuracy of 0.001 mm on diameter

NOTE: Vernier adjustment accuracy of 0.002 mm on diameter

IMPORTANT: Max spindle speed refers to maximum possible speed for an individual boring head and is not a recommended parameter. Refer to page B10-M: 12 for recommended application-specific parameters. Factory technical assistance is available for your specific applications through our Application Engineering department.
email: engineering.eu@alliedmachine.com

410 Unbalanced Boring Heads with 3E^{TECH+}

Diameter Range: 20.00 mm - 29.00 mm



Form 101

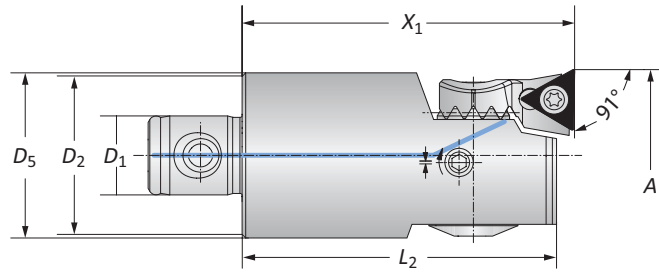

Form 20

410 Unbalanced Boring Heads with 3E^{TECH+}

	MVS Connection	Boring Range	Boring Head			Weight	Insert Form	Part No.	
	D ₂ D ₁	A	X ₁	L ₂	D ₅			Insert Holder	Boring Head
m	19 - 11	20.00 - 24.50	46.00	43.00	-	0.09 (kg)	20*	364077*	410001
	22 - 11	24.50 - 29.00	46.00	43.50	23.00	0.13 (kg)	20	210059	410002
	22 - 11	24.50 - 29.00	46.00	43.50	23.00	0.13 (kg)	101	210069	410002

*Not suitable for indexable inserts with a radius of 0.80 mm

NOTE: 3E^{TECH+} module, charging unit, insert holders, and inserts sold separately

3E^{TECH+} Digital Readout Module

Part No.	Charging Unit*
536015	536016

NOTE: WEEE-Reg.-Nr. DE 15820388

*Charging unit sold separately



NOTE: 3E^{TECH+} adjustment accuracy of 0.001 mm on diameter

Key on B10-A:1

B10-M: 12-13

B10-F

B10: VI-VII

m = Metric (mm)

IMPORTANT: Max spindle speed refers to maximum possible speed for an individual boring head and is not a recommended parameter. Refer to page B10-M: 12 for recommended application-specific parameters. Factory technical assistance is available for your specific applications through our Application Engineering department.
 email: engineering.eu@alliedmachine.com

464 Balanced Boring Heads with 3E^{TECH+}

Diameter Range: 29.00 mm - 65.50 mm



Form 101

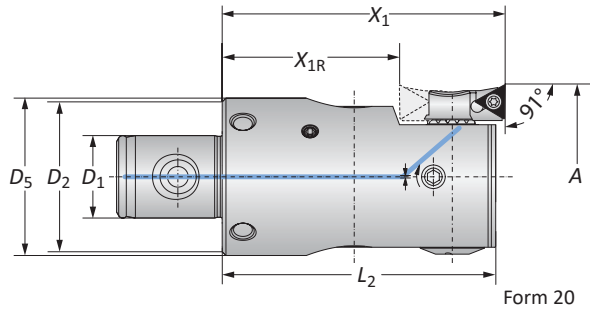

Form 20

464 Balanced Boring Heads with 3E^{TECH+}

MVS Connection	Boring Range	Boring Head					Weight	Insert Form	Part No.	
		D_2 D_1	A	X_1	X_{1R}	L_2			D_5	Insert Holder
	25 - 14	29.00 - 38.00	56.00	-	53.50	27.00	0.21 (kg)	20	210059	464003
	25 - 14	29.00 - 38.00	56.00	-	53.50	27.00	0.21 (kg)	101	210069	464003
	32 - 18	38.00 - 50.00	66.00	38.00	63.50	34.00	0.41 (kg)	20	264051	464004
	32 - 18	38.00 - 50.00	66.00	38.00	63.50	34.00	0.41 (kg)	101	264077	464004
	40 - 22	50.00 - 65.50	75.00	47.00	72.50	42.00	0.80 (kg)	20	210052	464005
	40 - 22	50.00 - 65.50	75.00	47.00	72.50	42.00	0.80 (kg)	101	210062	464005

NOTE: X_{1R} = rotated insert holder for reverse machining

NOTE: 3E^{TECH+} module, charging unit, insert holders, and inserts sold separately

3E^{TECH+} Digital Readout Module

Part No.	Charging Unit*
536015	536016

NOTE: WEEE-Reg.-Nr. DE 15820388

*Charging unit sold separately



NOTE: 3E^{TECH+} adjustment accuracy of 0.001 mm on diameter

B10-M: 12-13

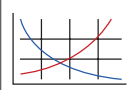

B10-F

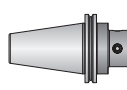

B10: VI-VII

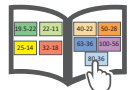

Key on B10-A:1

 = Metric (mm)

IMPORTANT: Max spindle speed refers to maximum possible speed for an individual boring head and is not a recommended parameter. Refer to page B10-M: 12 for recommended application-specific parameters. Factory technical assistance is available for your specific applications through our Application Engineering department.
 email: engineering.eu@alliedmachine.com

464 Balanced Boring Heads with 3E^{TECH+}

Alu-Line | Diameter Range: 65.00 mm - 205.00 mm



Form 101

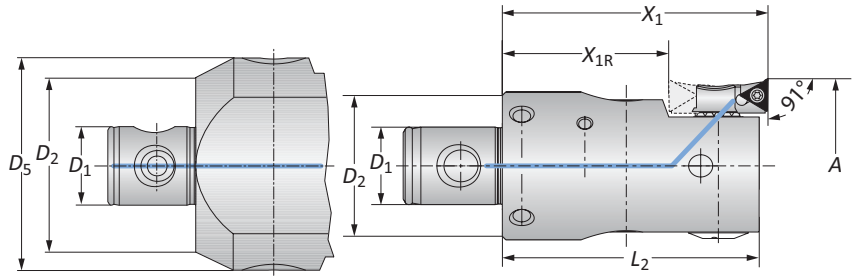

Form 20

464 Balanced Alu-Line Boring Heads with 3E^{TECH+}

MVS Connection	Boring Range	Boring Head					Weight	Insert Form	Part No.	
		D_2 D_1	A	X_1	X_{1R}	L_2			D_5	Insert Holder
	50 - 28	65.00 - 83.00	75.00	39.00	73.00	-	0.60 (kg)	20	210020	464006
	50 - 28	65.00 - 83.00	75.00	39.00	73.00	-	0.60 (kg)	101	210063	464006
	50 - 28	65.00 - 83.00	75.00	39.00	73.00	-	0.60 (kg)	103	210064	464006
	63 - 36	82.00 - 103.00	90.00	54.00	88.00	-	1.00 (kg)	20	210020	464007
	63 - 36	82.00 - 103.00	90.00	54.00	88.00	-	1.00 (kg)	101	210063	464007
	63 - 36	82.00 - 103.00	90.00	54.00	88.00	-	1.00 (kg)	103	210064	464007
	80 - 36	100.00 - 130.00	90.00	54.00	88.00	-	1.50 (kg)	20	210020	464008
m	80 - 36	100.00 - 130.00	90.00	54.00	88.00	-	1.50 (kg)	101	210063	464008
	80 - 36	100.00 - 130.00	90.00	54.00	88.00	-	1.50 (kg)	103	210064	464008
	80 - 36	125.00 - 167.50	90.00	54.00	88.00	100.00	1.90 (kg)	20	210020	464009
	80 - 36	125.00 - 167.50	90.00	54.00	88.00	100.00	1.90 (kg)	101	210063	464009
	80 - 36	125.00 - 167.50	90.00	54.00	88.00	100.00	1.90 (kg)	103	210064	464009
	80 - 36	162.50 - 205.00	90.00	54.00	88.00	135.00	2.50 (kg)	20	210020	464010
	80 - 36	162.50 - 205.00	90.00	54.00	88.00	135.00	2.50 (kg)	101	210063	464010
	80 - 36	162.50 - 205.00	90.00	54.00	88.00	135.00	2.50 (kg)	103	210064	464010

NOTE: X_{1R} = rotated insert holder for reverse machining

NOTE: 3E^{TECH+} module, insert holders, and inserts sold separately

3E^{TECH+} Digital Readout Module

Part No.	Charging Unit*
536015	536016

NOTE: WEEE-Reg.-Nr. DE 15820388

*Charging unit sold separately



NOTE: 3E^{TECH+} adjustment accuracy of 0.001 mm on diameter

B10-M: 12-13

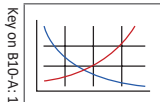

B10-F

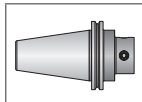

B10: VI-VII

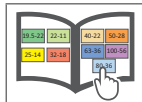

Key on B10-A:1

m = Metric (mm)

IMPORTANT: Max spindle speed refers to maximum possible speed for an individual boring head and is not a recommended parameter. Refer to page B10-M: 12 for recommended application-specific parameters. Factory technical assistance is available for your specific applications through our Application Engineering department.
email: engineering.eu@alliedmachine.com

Insert Holders for Abrasive Materials

Diameter Range: 65.00 mm - 205.00 mm

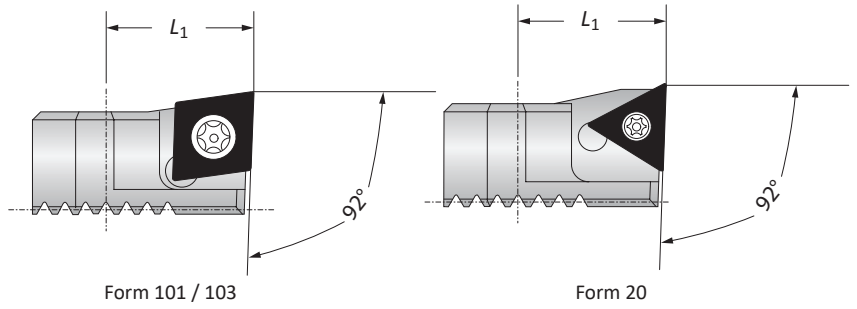
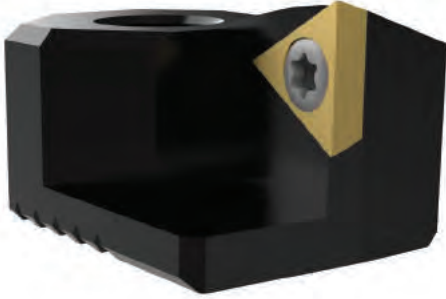

	Insert Holder				
	L_1	Weight	Insert Form	Part No.	
	65.00 - 205.00	18.00	0.03 (kg)	20	211061
	65.00 - 205.00	18.00	0.03 (kg)	101	211063
	65.00 - 205.00	18.00	0.03 (kg)	103	211065

NOTE: Insert holders used for abrasive materials to protect boring head against chip wash

NOTE: When machining grey cast iron, we recommend using insert holders for abrasive materials with CBN inserts for optimised chip removal.

Key on B10-B: 1

B10-M: 12-13

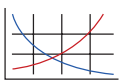

B10-H

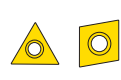

B10: VI-VII



 = Metric (mm)
Inserts sold separately

Accessories

Screws | 3E^{TECH+} Accessories

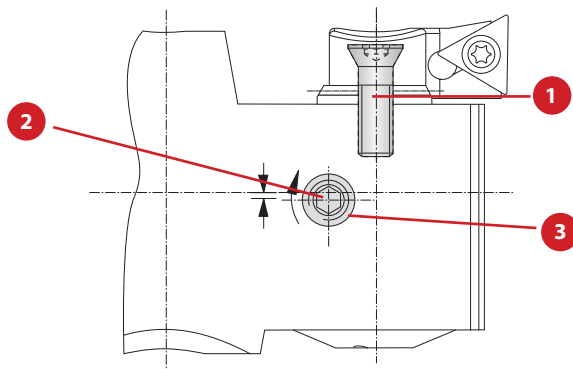

Screws

Boring Head	Part No.				
	1 Countersunk Screw	Countersunk Screw Service Key	2 Clamping Screw	Clamping Screw Service Key	3 Ball
410001	215323	T15 / H	410151	S2 / A	364270
410002	215338	T15 / H	410152	s2 / A	364270
464003	215338	T15 / H	364138	s2.5 / A	364139
464004	215338	T15 / H	115180	s2.5 / A	-
464005	215338	T15 / H	115505	s3 / B	-
464006	215462	T20 / H	315943	s4 / B	-
464007	215462	T20 / H	515178	s4 / B	-
464008	215462	T20 / H	515178	s4 / B	-
464009	215462	T20 / H	515178	s4 / B	-
464010	215462	T20 / H	515178	s4 / B	-

3E^{TECH+} Accessories

1 Charging Unit
Part No.
536016

NOTE: Charging unit sold separately from 3E^{TECH+}



NOTE: 3E^{TECH+} adjustment accuracy of 0.001 mm on diameter

3E^{TECH} Accessories (Old Display)

1 Sealing Ring	2 Battery CR2032
Part No.	Part No.
215483	515491

NOTE: Not required for 3E^{TECH+} (New Display)

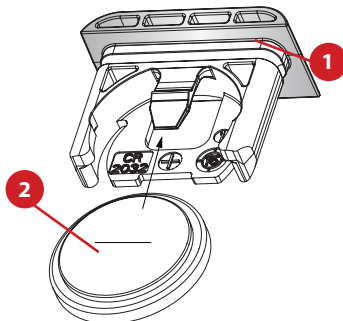

B10-M: 12-13

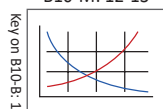

B10: VI-VII

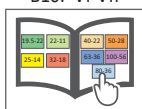

364 and 464 Product Overview

Balanced Analogue 364 and 464 FINE BORING

Analogue fine boring tools for high-production jobs

Wohlhaupter® 364 and 464 Analogue balanced boring heads offer precision boring with automatic balancing. Our boring heads are specifically engineered to minimise the residual imbalance produced by insert holder displacement. Wohlhaupter Alu-Line boring heads offer a lightweight aluminium design with a wear-resistant coating that reduces weight on the spindle up to 50% yet remains durable in challenging boring applications. The insert holder can also be rotated for reverse machining jobs.

- 364 diameter range: 20.00 mm - 29.50 mm
- 464 diameter range: 29.00 mm - 205.00 mm
- 464 Alu-Line diameter range: 65.00 mm - 205.00 mm
 - Special coating on Alu-Line for wear-resistant surface
 - Alu-Line body reduces tool weight by 50%, reducing stress on the spindle
- Internal balancing improves tool life and surface finish
- Through coolant
- Vernier diameter adjustment of 0.002 mm
- Insert holder can be rotated for back boring jobs
- Max cutting speed: 1,000 M/min



IMPORTANT: Max spindle speed refers to maximum possible speed for an individual boring head and is not a recommended parameter. Refer to page B10-M: 12 for recommended application-specific parameters. Factory technical assistance is available for your specific applications through our Application Engineering department.
email: engineering.eu@alliedmachine.com

WOHLHAUPTER® 464 BALANCED ANALOG BORING HEADS

Analogue BORING HEAD PART NUMBER CONVERSION		
Diameter Range	Old Part No.	<i>NEW</i> Part No.
20.00 - 24.50	364030	<i>No Change</i>
24.50 - 29.50	364031	<i>No Change</i>
29.00 - 38.00	364032	464033
38.00 - 50.00	364033	464034
50.00 - 65.50	364034	464035
65.00 - 83.00	364045	464036
82.00 - 103.00	364046	464037
100.00 - 130.00	364047	464038
125.00 - 167.50	364048	464039
162.50 - 205.00	364049	464040

- ✓ High-production fine boring
- ✓ Easy diameter adjustment
- ✓ Self-balancing
- ✓ Imperial and metric

FEATURES AN **ENHANCED** CLAMPING MECHANISM FROM OUR TRUSTED LINE OF 564 DIGITAL FINE BORING HEADS

Aluminium bodies with *wear-resistant* coating from 65.00 mm - 205.00 mm



Highly accurate adjustments through *vernier* scale



Equipped with *self-balancing* mechanism

364 / 464 Analogue Boring Heads

Diameter Range: 20.00 mm - 65.50 mm



364 Form 101

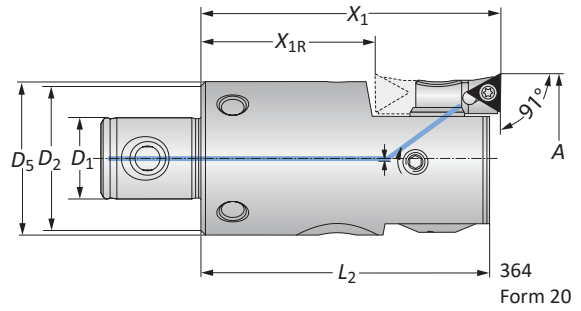
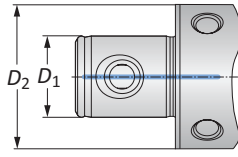

364 Form 20



464 Form 101

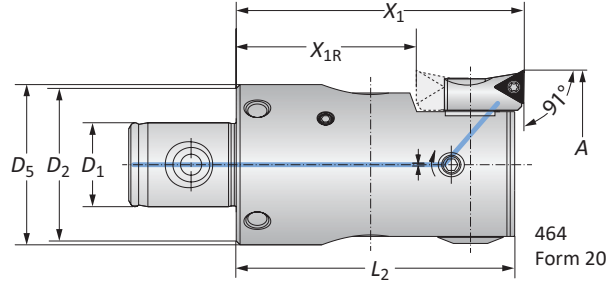

464 Form 20

364/464 Boring Heads

MVS Connection	Boring Range	Boring Head					Weight	Insert Form	Part No.		
		$D_2 D_1$	A	X_1	X_{1R}	L_2			D_5	Insert Holder	Boring Head
	20.00 - 24.50	19 - 11	20.00	46.00	-	43.00	-	0.09 (kg)	20*	364077	364030
	24.50 - 29.50	22 - 11	24.50	46.00	-	43.50	23.00	0.15 (kg)	20	210059	364031
	24.50 - 29.50	22 - 11	24.50	46.00	-	43.50	23.00	0.15 (kg)	101	210069	364031
	29.00 - 38.00	25 - 14	29.00	56.00	-	53.50	27.00	0.20 (kg)	20	210059	464033
m	29.00 - 38.00	25 - 14	29.00	56.00	-	53.50	27.00	0.20 (kg)	101	210069	464033
	38.00 - 50.00	32 - 18	38.00	66.00	38.00	63.50	34.00	0.40 (kg)	20	264051	464034
	38.00 - 50.00	32 - 18	38.00	66.00	38.00	63.50	34.00	0.40 (kg)	101	264077	464034
	50.00 - 65.50	40 - 22	50.00	75.00	47.00	72.50	42.00	0.80 (kg)	20	210052	464035
	50.00 - 65.50	40 - 22	50.00	75.00	47.00	72.50	42.00	0.80 (kg)	101	210062	464035

*Not suitable for indexable inserts with a radius of 0.80 mm

NOTE: X_{1R} = rotated insert holder for reverse machining

NOTE: Insert holders and inserts sold separately

B10-M: 12-13

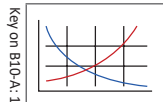

B10-F

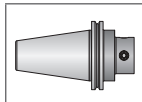

B10: VI-VII

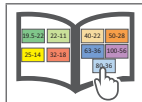

Key on B10-A:1

m = Metric (mm)

IMPORTANT: Max spindle speed refers to maximum possible speed for an individual boring head and is not a recommended parameter. Refer to page B10-M: 12 for recommended application-specific parameters. Factory technical assistance is available for your specific applications through our Application Engineering department.
email: engineering.eu@alliedmachine.com

464 Analogue Boring Heads

Alu-Line | Diameter Range: 65.00 mm - 205.00 mm



Form 101

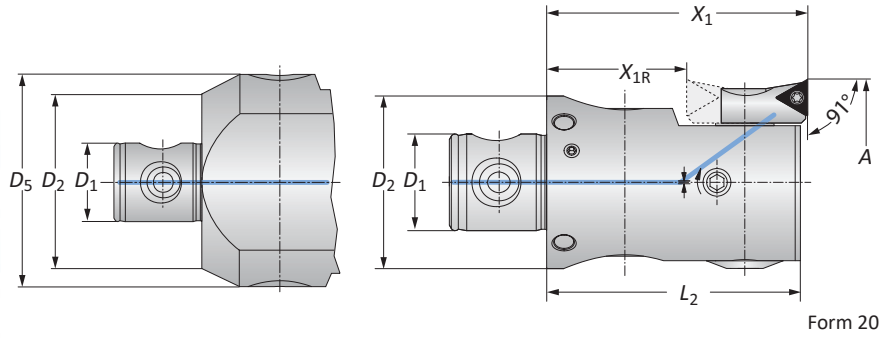

Form 20

464 Alu-Line Boring Heads

MVS Connection	Boring Range	Boring Head				Weight	Insert Form	Part No.	
		D_2 D_1	A	X_1	X_{1R}			L_2	D_5
50 - 28	65.00 - 83.00	75.00	39.00	72.50	-	0.60 (kg)	20	210020	464036
50 - 28	65.00 - 83.00	75.00	39.00	72.50	-	0.60 (kg)	101	210063	464036
50 - 28	65.00 - 83.00	75.00	39.00	72.50	-	0.60 (kg)	103	210064	464036
63 - 36	82.00 - 103.00	90.00	54.00	87.50	-	1.00 (kg)	20	210020	464037
63 - 36	82.00 - 103.00	90.00	54.00	87.50	-	1.00 (kg)	101	210063	464037
63 - 36	82.00 - 103.00	90.00	54.00	87.50	-	1.00 (kg)	103	210064	464037
80 - 36	100.00 - 130.00	90.00	54.00	87.50	-	1.50 (kg)	20	210020	464038
80 - 36	100.00 - 130.00	90.00	54.00	87.50	-	1.50 (kg)	101	210063	464038
80 - 36	100.00 - 130.00	90.00	54.00	87.50	-	1.50 (kg)	103	210064	464038
80 - 36	125.00 - 167.50	90.00	54.00	87.50	100.00	1.90 (kg)	20	210020	464039
80 - 36	125.00 - 167.50	90.00	54.00	87.50	100.00	1.90 (kg)	101	210063	464039
80 - 36	125.00 - 167.50	90.00	54.00	87.50	100.00	1.90 (kg)	103	210064	464039
80 - 36	162.50 - 205.00	90.00	54.00	87.50	135.00	2.50 (kg)	20	210020	464040
80 - 36	162.50 - 205.00	90.00	54.00	87.50	135.00	2.50 (kg)	101	210063	464040
80 - 36	162.50 - 205.00	90.00	54.00	87.50	135.00	2.50 (kg)	103	210064	464040

NOTE: X_{1R} = rotated insert holder for reverse machining

NOTE: Insert holders and inserts sold separately

B10-M: 12-13

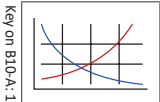

B10-F

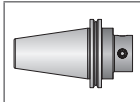

B10: VI-VII



 = Metric (mm)

IMPORTANT: Max spindle speed refers to maximum possible speed for an individual boring head and is not a recommended parameter. Refer to page B10-M: 12 for recommended application-specific parameters. Factory technical assistance is available for your specific applications through our Application Engineering department.
 email: engineering.eu@alliedmachine.com

Insert Holders for Abrasive Materials

Diameter Range: 265.00 mm - 205.00 mm

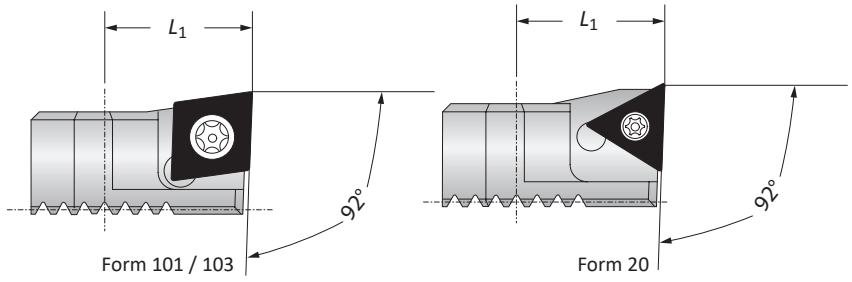
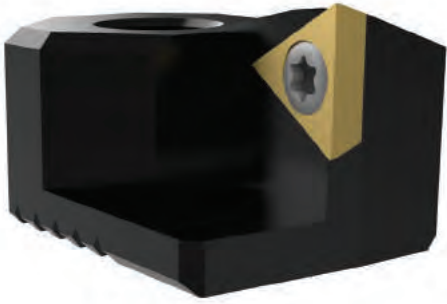

	Insert Holder			
	Boring Range	L_1	Weight	Insert Form
Ⓜ	65.00 - 205.00	18.00	0.03 (kg)	20
	65.00 - 205.00	18.00	0.03 (kg)	101
	65.00 - 205.00	18.00	0.03 (kg)	103
				Part No.
				211061
				211063
				211065

NOTE: Insert holders used for abrasive materials to protect boring head against chip wash

NOTE: When machining grey cast iron, we recommend using insert holders for abrasive materials with CBN inserts for optimised chip removal.

B10-M: 12-13

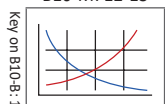

B10-H

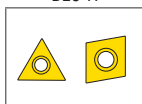

B10: VI-VII



Ⓜ = Metric (mm)

Inserts sold separately

Accessories

Screws

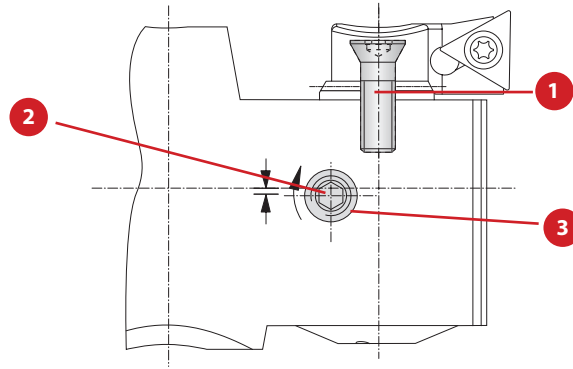

Boring Head	Part No.				
	1 Countersunk Screw	Countersunk Screw Service Key	2 Clamping Screw	Clamping Screw Service Key	3 Ball
364030	215323	T15 / H	364260	s2 / A	364270
364031	215338	T15 / H	364138	s2.5 / A	364139
464033	215338	T15 / H	364138	s2.5 / A	364139
464034	215338	T15 / H	115180	s2.5 / A	-
464035	215338	T15 / H	115505	s3 / B	-
464036	215462	T20 / H	315943	s4 / B	-
464037	215462	T20 / H	515178	s4 / B	-
464038	215462	T20 / H	515178	s4 / B	-
464039	215462	T20 / H	515178	s4 / B	-
464040	215462	T20 / H	515178	s4 / B	-

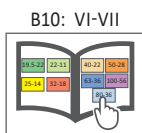
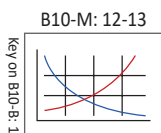

Balanced Digital 564 Product Overview

Balanced Digital 564 FINE BORING

Adjustable diameter for precise machining.

Wohlhaupter® Balance Digital 564 boring heads feature automatic balancing with an easy-to-read digital display. For diameter ranges above 65.00 mm, 564 boring heads are made of lightweight aluminium. 564 boring heads are specifically engineered to minimise the residual imbalance produced by insert holder displacement. Reverse boring applications can be achieved by rotating the insert holders.

Test the **engineered lightweight** boring head today.

- Diameter range: 50.00 mm - 205.00 mm
- Alu-Line diameter range: 65.00 mm - 205.00 mm
 - Special coating on Alu-Line for wear-resistant surface
 - Alu-Line body reduces tool weight by 50%, reducing stress on the spindle
- Digital readout advantage for diameter adjustments of 0.002 mm
- Through coolant
- Internal balancing improves tool life and surface finish
- Insert holder can be rotated for back boring jobs
- Max cutting speed: 2,000 M/min
- Max coolant pressure: 40 bar



Aluminium Boring Head
65.00 mm - 205.00 mm

Steel Boring Head
50.00 mm - 65.50 mm

NOTE: Metric items pictured

NOTE: Digital adjustment accuracy of 0.002 mm on diameter

IMPORTANT: Max spindle speed refers to maximum possible speed for an individual boring head and is not a recommended parameter. Refer to page B10-M: 12 for recommended application-specific parameters. Factory technical assistance is available for your specific applications through our Application Engineering department.
email: engineering.eu@alliedmachine.com

WOHLHAUPTER® 564 BORING HEAD with NOVI^{TECH}

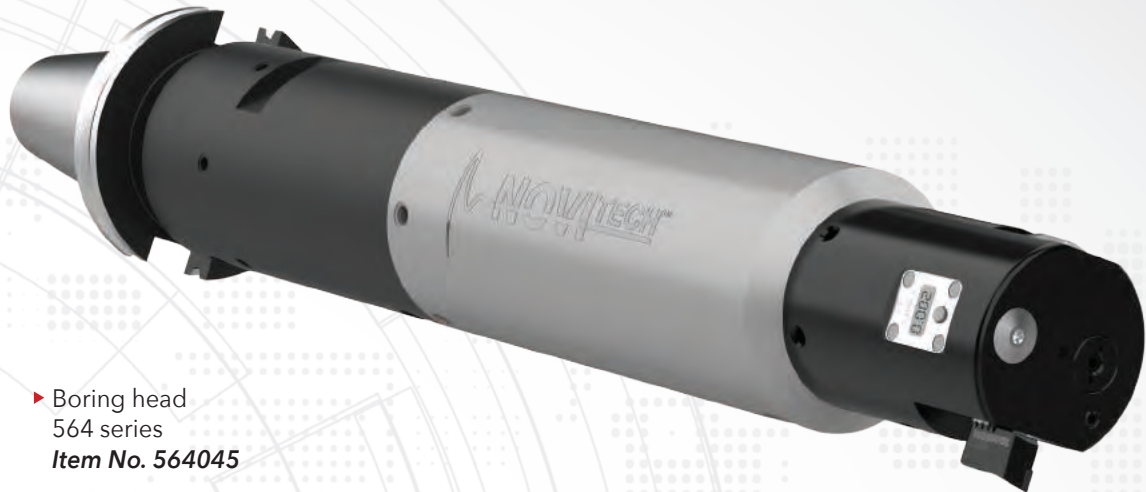

- ▶ Boring head
564 series
Item No. 564045
- ▶ NOVI^{TECH} vibration dampening
intermediate module
Item No. 519005

NOTE: Metric items pictured

NOTE: Digital adjustment accuracy of
0.002 mm on diameter

*The Wohlhaupter 564 boring head with the
NOVI^{TECH} vibration dampening module provided:*



Excellent surface finish



Eliminated vibration and chatter

		Measure	564 Boring Head with NOVI ^{TECH}
Product:	Wohlhaupter 564 Boring Head with NOVI ^{TECH}	RPM	430 RPM
Objectives:	0.05 mm concentricity over the length of two bores spaced 355.6 mm apart	Speed	107.28 M/min
Material:	Cast iron	Feed Rate	0.08 mm/rev
Hole Ø:	79.375 mm	Penetration Rate	33 mm/min
Depth:	7xD	Cycle Time (per hole)	3 min 32 sec
		Hole Finish	3.8 Ra

Boring Heads

Diameter Range: 50.00 mm - 65.50 mm



NOTE: Metric item pictured
NOTE: Digital adjustment accuracy of 0.002 mm on diameter

Form 101

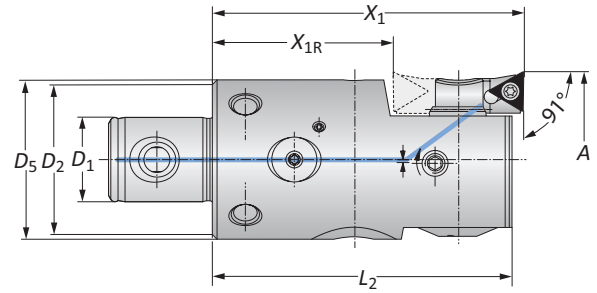

Form 20

564 Digital Boring Heads

	MVS Connection	Boring Range	Boring Head				Weight	Insert Form	Part No.	
	D ₂ D ₁		A	X ₁	X _{1R}	L ₂			D ₅	Insert Holder
m	40 - 22	50.00 - 65.50	75.00	47.00	72.50	42.00	0.80 (kg)	20	210052	564034
	40 - 22	50.00 - 65.50	75.00	47.00	72.50	42.00	0.80 (kg)	101	210062	564034

NOTE: X_{1R} = rotated insert holder for reverse machining
NOTE: Insert holders and inserts sold separately

B10-M: 12-13

B10-F

B10: VI-VII

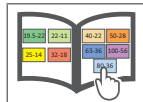
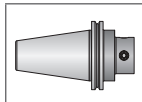
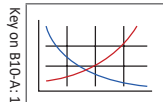

m = Metric (mm)

IMPORTANT: Max spindle speed refers to maximum possible speed for an individual boring head and is not a recommended parameter. Refer to page B10-M: 12 for recommended application-specific parameters. Factory technical assistance is available for your specific applications through our Application Engineering department.
 email: engineering.eu@alliedmachine.com

Boring Heads

Alu-Line | Diameter Range: 65.00 mm - 205.00 mm



Form 101

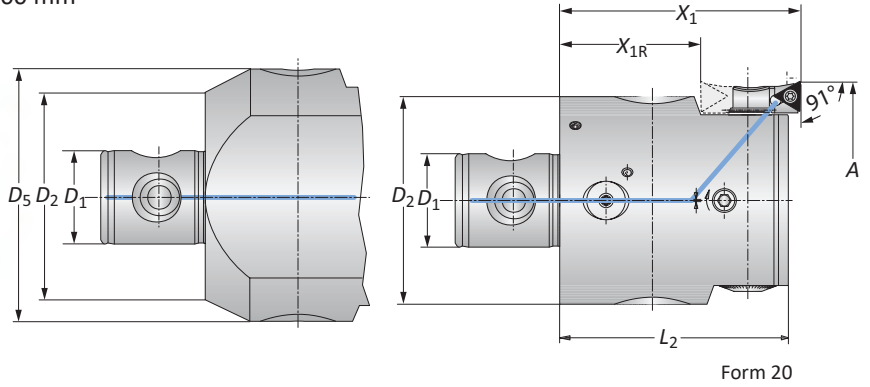

Form 20

NOTE: Metric item pictured
NOTE: Digital adjustment accuracy of 0.002 mm on diameter

564 Digital Alu-Line Boring Heads

MVS Connection	Boring Range	Boring Head					Weight	Insert Form	Part No.	
		$D_2 D_1$	A	X_1	X_{1R}	L_2			D_5	Insert Holder
m	50 - 28	65.00 - 83.00	75.00	39.00	73.00	-	0.60 (kg)	20	210020	564045
	50 - 28	65.00 - 83.00	75.00	39.00	73.00	-	0.60 (kg)	101	210063	564045
	50 - 28	65.00 - 83.00	75.00	39.00	73.00	-	0.60 (kg)	103	210064	564045
	63 - 36	82.00 - 103.00	90.00	54.00	88.00	-	1.00 (kg)	20	210020	564046
	63 - 36	82.00 - 103.00	90.00	54.00	88.00	-	1.00 (kg)	101	210063	564046
	63 - 36	82.00 - 103.00	90.00	54.00	88.00	-	1.00 (kg)	103	210064	564046
	80 - 36	100.00 - 130.00	90.00	54.00	88.00	-	1.50 (kg)	20	210020	564047
	80 - 36	100.00 - 130.00	90.00	54.00	88.00	-	1.50 (kg)	101	210063	564047
	80 - 36	100.00 - 130.00	90.00	54.00	88.00	-	1.50 (kg)	103	210064	564047
	80 - 36	125.00 - 167.50	90.00	54.00	88.00	100.00	1.90 (kg)	20	210020	564048
	80 - 36	125.00 - 167.50	90.00	54.00	88.00	100.00	1.90 (kg)	101	210063	564048
	80 - 36	125.00 - 167.50	90.00	54.00	88.00	100.00	1.90 (kg)	103	210064	564048
80 - 36	162.50 - 205.00	90.00	54.00	88.00	135.00	2.50 (kg)	20	210020	564049	
80 - 36	162.50 - 205.00	90.00	54.00	88.00	135.00	2.50 (kg)	101	210063	564049	
80 - 36	162.50 - 205.00	90.00	54.00	88.00	135.00	2.50 (kg)	103	210064	564049	

NOTE: X_{1R} = rotated insert holder for reverse machining
NOTE: Insert holders and inserts sold separately

B10-M: 12-13

B10-F

B10: VI-VII

m = Metric (mm)

IMPORTANT: Max spindle speed refers to maximum possible speed for an individual boring head and is not a recommended parameter. Refer to page B10-M: 12 for recommended application-specific parameters. Factory technical assistance is available for your specific applications through our Application Engineering department.
 email: engineering.eu@alliedmachine.com

Insert Holder for Abrasive Materials

Diameter Range: 65.00 mm - 205.00 mm

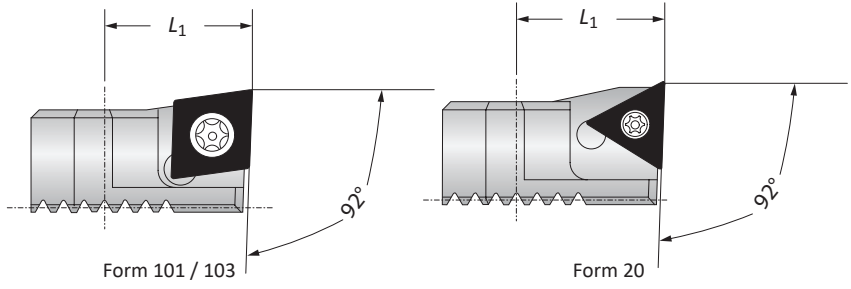
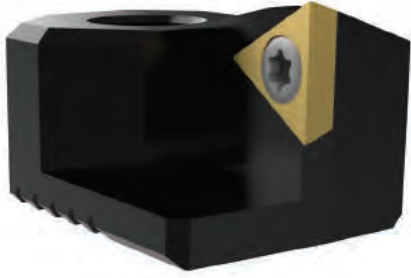

	Insert Holder				
	Boring Range	L_1	Weight	Insert Form	Part No.
m	65.00 - 205.00	18.00	0.03 (kg)	20	211061
	65.00 - 205.00	18.00	0.03 (kg)	101	211063
	65.00 - 205.00	18.00	0.03 (kg)	103	211065

NOTE: Insert holders used for abrasive materials to protect boring head against chip wash

NOTE: When machining grey cast iron, we recommend using insert holders for abrasive materials with CBN inserts for optimised chip removal.

B10-M: 12-13

B10-H

B10: VI-VII

Accessories

Screws | Battery Cover | Batteries

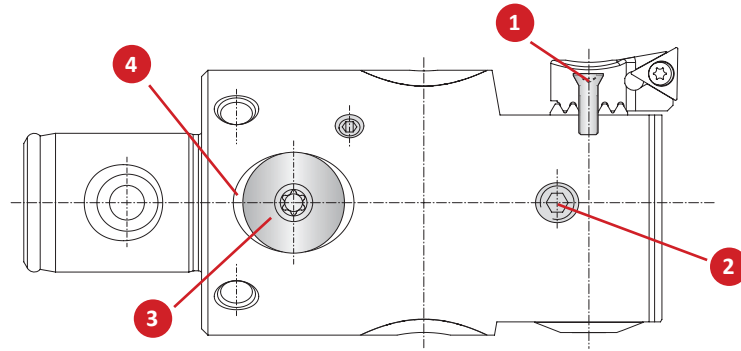

Boring Head	Part No.							
	1 Countersunk Screw	Service Key	2 Clamping Screw	Service Key	3 Battery Cover	Service Key	4 Sealing Ring	Battery*
564034	215338	T15 / H	115505	s3 / B	501016	T20 / H	415895	415896
564045	215462	T20 / H	315943	s4 / B	501016	T20 / H	415895	415896
564046	215462	T20 / H	515178	s4 / B	501016	T20 / H	415895	415896
564047	215462	T20 / H	515178	s4 / B	501016	T20 / H	415895	415896
564048	215462	T20 / H	515178	s4 / B	501016	T20 / H	415895	415896
564049	215462	T20 / H	515178	s4 / B	501016	T20 / H	415895	415896

*Replace both batteries

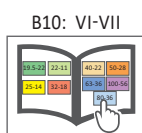
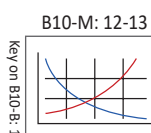

310 Product Overview

310 FINE BORING

Engineered with wear and tear in mind.

310 Wohlhaupter boring heads are made from steel for \varnothing 20.00 mm - 103.00 mm and coated Alu-Line material for \varnothing 100.00 mm - 205.00 mm boring heads to protect against corrosion and wear. The insert holder can be rotated quickly for reverse machining.

- Diameter range: 20.00 mm - 205.00 mm
- Alu-Line diameter range: 100.00 mm - 205.00 mm
 - Special coating on Alu-Line provides hard, durable surface
 - Alu-Line body reduces tool weight by 50%, reducing stress on the spindle
- Through coolant
- Vernier diameter adjustment of 0.002 mm
- Max cutting speed: 1,000 M/min



IMPORTANT: Max spindle speed refers to maximum possible speed for an individual boring head and is not a recommended parameter. Refer to page B10-M: 12 for recommended application-specific parameters. Factory technical assistance is available for your specific applications through our Application Engineering department.
email: engineering.eu@alliedmachine.com

WOHLHAUPTER® 310 BORING HEAD with NOVI^{TECH}

Time is money, so make it count.

If you want to improve your machining processes, cycle time is a key factor to examine. Our customer was experiencing lengthy cycle times while machining pumps from grey cast iron. The parts required three bored holes, each with a 304.8 mm depth and a 558.8 mm reach.

In order to free up machine time, the customer questioned if their process could be more efficient. The main objectives were to decrease the current cycle time and to maintain a 4 Ra finish, which was required to perform the burnishing process that followed.

The previous tooling ran at a slow 11.938 mm/min and a slow 84-minute cycle time to bore the three holes on each part. With our **Wohlhaupter 310 boring head** utilising the **NOVI^{TECH} vibration dampening module**, the customer increased to a more efficient 95.25 mm/min and slashed the cycle time to 10.5 minutes (an 87% decrease). Along with the increased speed, the Wohlhaupter tooling also achieved a 4 Ra finish, accomplishing everything the customer needed.

The Wohlhaupter solution reduced the process cycle time by 74 minutes. Improvements in speed and cycle time can free up machine hours, which means more throughput and higher profit for your company. **Are you losing money on applications with substantially long cycle times?**



Product:	Wohlhaupter 310 Boring Head with NOVI ^{TECH}	Measure	Competitor Boring Head	310 Boring Head w/ NOVI ^{TECH}
Objectives:	(1) Decrease cycle time (2) Maintain 4 Ra hole finish	RPM	39	469
Industry:	Oil & gas/petrochemical	Speed Rate	17.069 M/min	205.74 M/min
Part:	Pump	Feed Rate	0.305 mm/rev	0.203 mm/rev
Material:	Grey cast iron	Penetration Rate	11.938 mm/min	92.25 mm/min
Hole Ø:	139.7 mm	Cycle Time (per hole)	27 min 54 sec	3 min 32 sec
Hole Depth:	304.8 mm	Hole Finish	4 Ra	3.8 Ra

▶ Boring head
310 series
Item No. 310008

▶ NOVI^{TECH}
vibration dampening
intermediate module
Item No. 519005



The Wohlhaupter 310 boring head with the NOVI^{TECH} vibration dampening module provided:

- ✓ Increased penetration rate
- ✓ Decreased cycle time
- ✓ Excellent finish in deep hole application

74 minute
cycle time reduction

Boring Heads

Diameter Range: 20.00 mm - 103.00 mm

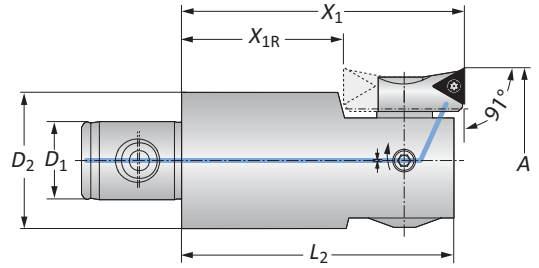
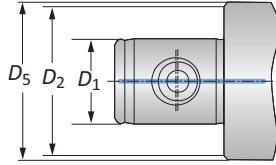

Form 101 / 103

Form 20

310 Boring Heads

MVS Connection	Boring Range	Boring Head					Weight	Insert Form	Part No.	
		D_2 D_1	A	X_1	X_{1R}	L_2			D_5	Insert Holder
19 - 11	20.00 - 24.50	46.00	-	43.00	-	0.10 (kg)	20*	364077	310010	
22 - 11	24.50 - 29.50	46.00	-	43.50	23.00	0.15 (kg)	20	210059	310020	
22 - 11	24.50 - 29.50	46.00	-	43.50	23.00	0.15 (kg)	101	210069	310020	
25 - 14	29.00 - 37.00	56.00	-	53.50	26.00	0.20 (kg)	20	210059	310001	
25 - 14	29.00 - 37.00	56.00	-	53.50	26.00	0.20 (kg)	101	210069	310001	
25 - 14	36.00 - 44.00	56.00	28.00	53.50	26.00	0.20 (kg)	20	210052	310001	
25 - 14	36.00 - 44.00	56.00	28.00	53.50	26.00	0.20 (kg)	101	210062	310001	
32 - 18	43.00 - 54.00	66.00	38.00	63.50	-	0.40 (kg)	20	210052	310003	
32 - 18	43.00 - 54.00	66.00	38.00	63.50	-	0.40 (kg)	101	210062	310003	
40 - 22	53.00 - 66.00	75.00	39.00	72.50	-	0.70 (kg)	20	210020	310004	
40 - 22	53.00 - 66.00	75.00	39.00	72.50	-	0.70 (kg)	101	210063	310004	
40 - 22	53.00 - 66.00	75.00	39.00	72.50	-	0.70 (kg)	103	210064	310004	
50 - 28	65.00 - 83.00	75.00	39.00	72.50	-	1.20 (kg)	20	210020	310005	
50 - 28	65.00 - 83.00	75.00	39.00	72.50	-	1.20 (kg)	101	210063	310005	
50 - 28	65.00 - 83.00	75.00	39.00	72.50	-	1.20 (kg)	103	210064	310005	
63 - 36	82.00 - 103.00	90.00	54.00	87.50	-	2.20 (kg)	20	210020	310006	
63 - 36	82.00 - 103.00	90.00	54.00	87.50	-	2.20 (kg)	101	210063	310006	
63 - 36	82.00 - 103.00	90.00	54.00	87.50	-	2.20 (kg)	103	210064	310006	

*Not suitable for indexable inserts with a radius of 0.80 mm

NOTE: X_{1R} = rotated insert holder for reverse machining

NOTE: Insert holders and inserts sold separately

B10-M: 12-13

B10-F

B10: VI-VII

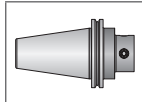
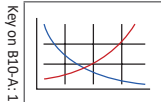

m = Metric (mm)

IMPORTANT: Max spindle speed refers to maximum possible speed for an individual boring head and is not a recommended parameter. Refer to page B10-M: 12 for recommended application-specific parameters. Factory technical assistance is available for your specific applications through our Application Engineering department.
email: engineering.eu@alliedmachine.com

Boring Heads

Alu-Line | Diameter Range: 100.00 mm - 205.00 mm



Form 101 / 103

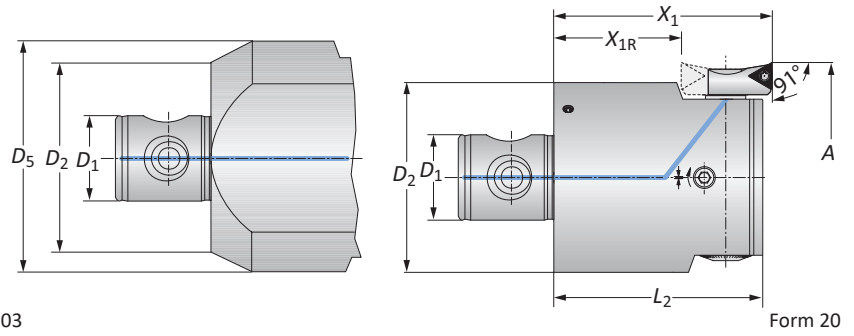

Form 20

Alu-Line 310 Boring Heads

MVS Connection	Boring Range	Boring Head					Weight	Insert Form	Part No.	
		D_2 D_1	A	X_1	X_{1R}	L_2			D_5	Insert Holder
	80 - 36	100.00 - 130.00	90.00	54.00	87.50	-	1.40 (kg)	20	210020	310007
	80 - 36	100.00 - 130.00	90.00	54.00	87.50	-	1.40 (kg)	101	210063	310007
	80 - 36	100.00 - 130.00	90.00	54.00	87.50	-	1.40 (kg)	103	210064	310007
	80 - 36	125.00 - 167.50	90.00	54.00	87.50	100.00	1.80 (kg)	20	210020	310008
	80 - 36	125.00 - 167.50	90.00	54.00	87.50	100.00	1.80 (kg)	101	210063	310008
	80 - 36	125.00 - 167.50	90.00	54.00	87.50	100.00	1.80 (kg)	103	210064	310008
	80 - 36	162.50 - 205.00	90.00	54.00	87.50	135.00	2.40 (kg)	20	210020	310009
	80 - 36	162.50 - 205.00	90.00	54.00	87.50	135.00	2.40 (kg)	101	210063	310009
	80 - 36	162.50 - 205.00	90.00	54.00	87.50	135.00	2.40 (kg)	103	210064	310009

NOTE: X_{1R} = rotated insert holder for reverse machining

NOTE: Insert holders and inserts sold separately

B10-M: 12-13

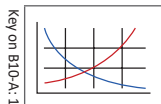

B10-F

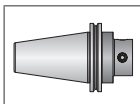

B10: VI-VII

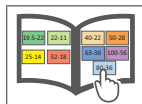

 = Metric (mm)

IMPORTANT: Max spindle speed refers to maximum possible speed for an individual boring head and is not a recommended parameter. Refer to page B10-M: 12 for recommended application-specific parameters. Factory technical assistance is available for your specific applications through our Application Engineering department.
 email: engineering.eu@alliedmachine.com

Insert Holders for Abrasive Materials | Serrated Shims

Diameter Range: 53.00 mm - 205.00 mm

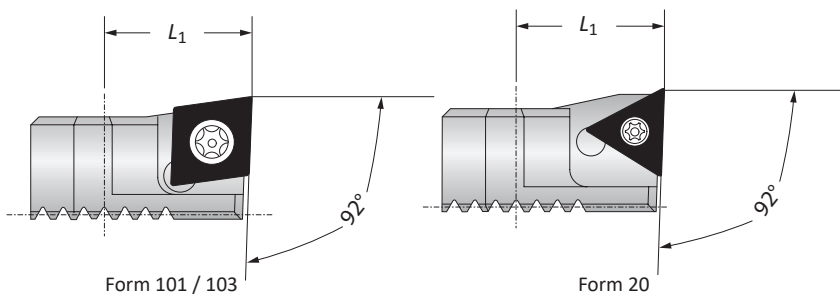
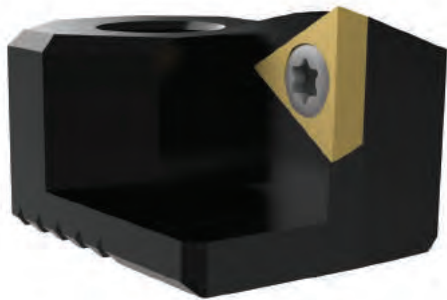

Insert Holders

	Boring Range	Insert Holder L_1	Weight	Insert Form	Part No.
m	53.00 - 205.00	18.00	0.03 (kg)	20	211061
	53.00 - 205.00	18.00	0.03 (kg)	101	211063
	53.00 - 205.00	18.00	0.03 (kg)	103	211065

NOTE: Insert holders used for abrasive materials to protect boring head against chip wash

NOTE: When machining grey cast iron, we recommend using insert holders for abrasive materials with CBN inserts for optimised chip removal.

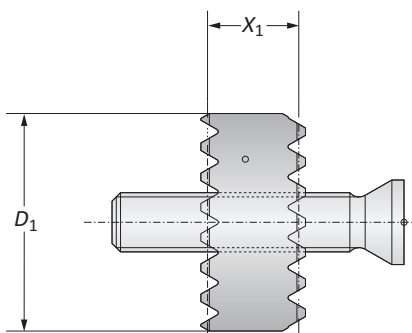

Serrated Shims

	Boring Range	Additional Boring Range	Serrated Shim		Weight	Part No.	
			X_1	D_1		Serrated Shim & Screw	Replacement Screw
m	29.00 - 54.00	8.00	4.00	12.00	0.01 (kg)	310070	415360
	29.00 - 54.00	12.00	6.00	12.00	0.01 (kg)	310071	415342
	53.00 - 205.00	10.00	5.00	18.00	0.01 (kg)	310074	515595
	53.00 - 205.00	15.00	7.50	18.00	0.01 (kg)	310075	515596

Key on B10-B: 1

B10-M: 12-13

B10-H

B10: VI-VII

m = Metric (mm)
Inserts sold separately

Accessories

Screws

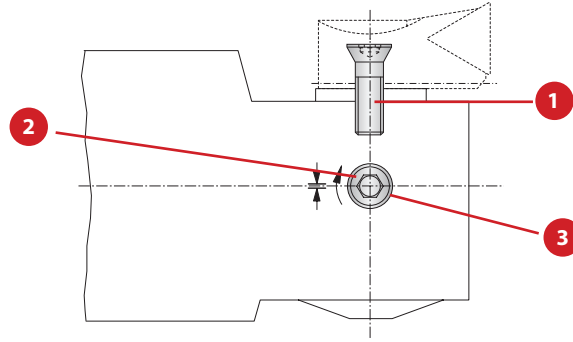

Boring Head	1 Countersunk Screw		2 Clamping Screw		3 Ball
	Part No.	Service Key	Part No.	Service Key	Part No.
310010	215323	T15 / H	364260	s2.0 / A	364270
310020	215338	T15 / H	364138	s2.5 / A	364139
310001	215338	T15 / H	115136	s2.5 / A	-
310003	215338	T15 / H	115180	s2.5 / A	-
310004	215462	T20 / H	115249	s4 / B	-
310005	215462	T20 / H	115185	s4 / B	-
310006	215462	T20 / H	315279	s4 / B	-
310007	215462	T20 / H	115186	s4 / B	-
310008	215462	T20 / H	115186	s4 / B	-
310009	215462	T20 / H	115186	s4 / B	-

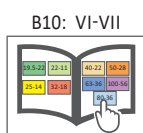
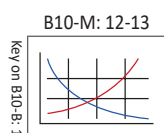

537 Product Overview



537 Cassettes FINE BORING

Engineered for easy precision.

537 fine boring cassettes offer high accuracy and are available in an easy-to-use digital or Analogue version. The digital version features a docking port to attach the 3E^{TECH+} digital readout module for μ -accurate diameter adjustments while the Analogue cassettes provide highly accurate adjustments through the vernier scale. 537 cassettes are made of hardened steel and can be used on serrated tool bodies and slides from 100.00 mm - 3255.00 mm. The insert holder can be rotated easily for reverse machining applications.

Experience **digital precision boring** for yourself.

- Diameter range: 100.00 mm - 205.00 mm
- Cassette can be used on large diameter serrated slides (**pg. B10-G: 8**): 200.00 mm - 3255.00 mm
- Through coolant
- 3E^{TECH+} module provides a simple digital readout
- Analogue version with a vernier scale
- Max cutting speed: 900 M/min



NOTE: 3E^{TECH+} adjustment accuracy of 0.001 mm on diameter

NOTE: Vernier adjustment accuracy of 0.002 mm on diameter

IMPORTANT: Max spindle speed refers to maximum possible speed for an individual boring head and is not a recommended parameter. Refer to page B10-M: 12 for recommended application-specific parameters. Factory technical assistance is available for your specific applications through our Application Engineering department.
email: engineering.eu@alliedmachine.com

537 BORING CASSETTES



NEW vernier scale
on both Analogue
and digital cassettes

NEW digital 537
cassettes with 3E^{TECH}
docking port

- ✓ Convenient tool handling
- ✓ Large range of applications
- ✓ Hardened steel bodies

537 Analogue Cassettes

Diameter Range: 100.00 mm - 205.00 mm



Form 101 / 103

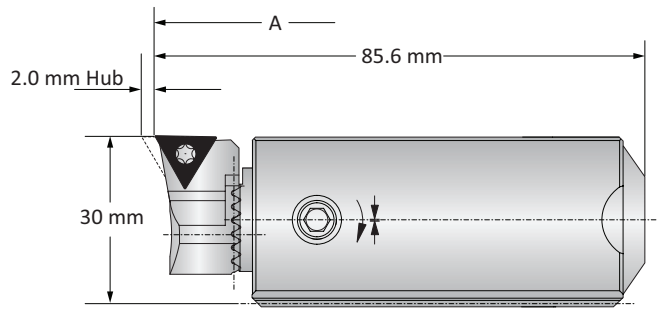

Form 20

Analogue 537 Cassettes

	Boring Range	Weight	Insert Form	Part No.		
				Insert Holder	Clamping Piece	Cassette*
Ⓜ	100.00 - 205.00	0.60 (kg)	20	210020	137026	537051
	100.00 - 205.00	0.60 (kg)	101	210063	137026	537051
	100.00 - 205.00	0.60 (kg)	103	210064	137026	537051

*Required serrated tool body sold separately

NOTE: Cassette and insert holder can be used on large diameter serrated slides (B10-G: 8)

NOTE: Insert holders, inserts, and clamping pieces *sold separately*

B10-M: 12-13

B10-F

B10: VI-VII

Key on B10-A:1

Ⓜ = Metric (mm)

IMPORTANT: Max spindle speed refers to maximum possible speed for an individual boring head and is not a recommended parameter. Refer to page B10-M: 12 for recommended application-specific parameters. Factory technical assistance is available for your specific applications through our Application Engineering department.
 email: engineering.eu@alliedmachine.com

537 Cassettes with 3E^{TECH+}

Diameter Range: 100.00 mm - 205.00 mm



Form 101 / 103

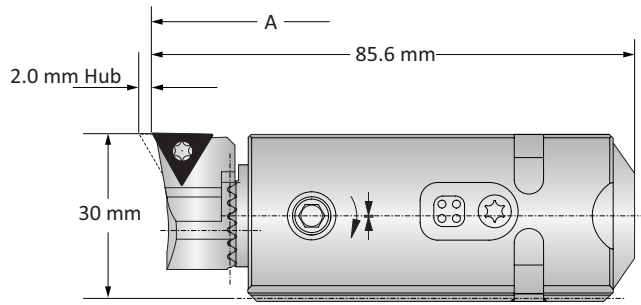

Form 20

Digital 537 Cassettes

	Boring Range	Weight	Insert Form	Part No.		
				Insert Holder	Clamping Piece	Cassette*
Ⓜ	100.00 - 205.00	0.60 (kg)	20	210020	137026	537052
	100.00 - 205.00	0.60 (kg)	101	210063	137026	537052
	100.00 - 205.00	0.60 (kg)	103	210064	137026	537052

*Required serrated tool body sold separately

NOTE: Cassette and insert holder can be used on large diameter serrated slides (B10-G: 8)

NOTE: 3E^{TECH+} digital readout module, charging unit, insert holders, inserts, and clamping pieces ***sold separately***

3E^{TECH+} Digital Readout Module

Part No.	Charging Unit*
536015	536016

NOTE: WEEE-Reg.-Nr. DE 15820388

*Charging unit sold separately



NOTE: 3E^{TECH+} adjustment accuracy of 0.001 mm on diameter

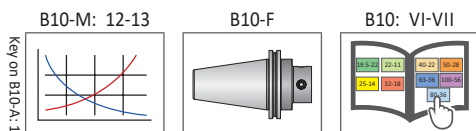

Ⓜ = Metric (mm)

IMPORTANT: Max spindle speed refers to maximum possible speed for an individual boring head and is not a recommended parameter. Refer to page B10-M: 12 for recommended application-specific parameters. Factory technical assistance is available for your specific applications through our Application Engineering department.
 email: engineering.eu@alliedmachine.com

Serrated Tool Bodies | Insert Holders for Abrasive Materials

Diameter Range: 100.00 mm - 205.00 mm

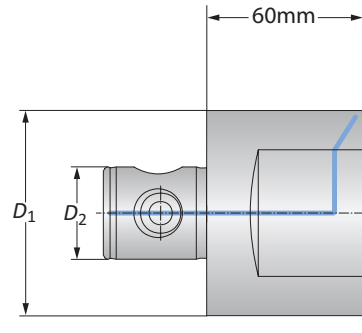

Serrated Tool Bodies

MVS Connection		Serrated Tool Body	
	D_2 D_1	Boring Range	Part No.
m	80 - 36	100.00 - 155.00	148007
	80 - 36	150.00 - 205.00	148009

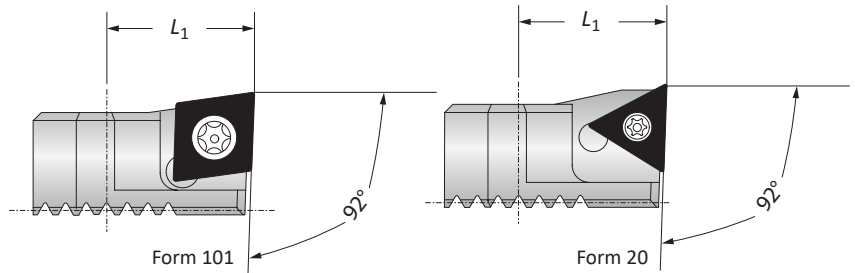
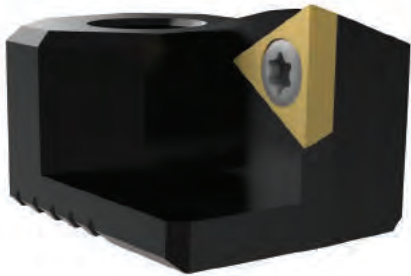

Insert Holders for Abrasive Materials

		Insert Holder			
		L_1	Weight	Insert Form	Part No.
m	100.00 - 205.00	18.00	0.03 (kg)	20	211061
	100.00 - 205.00	18.00	0.03 (kg)	101	211063
	100.00 - 205.00	18.00	0.03 (kg)	103	211065

NOTE: Insert holders used for abrasive materials to protect boring head against chip wash

NOTE: When machining grey cast iron, we recommend using insert holders for abrasive materials with CBN inserts for optimised chip removal.

B10-M: 12-13

B10-H

B10: VI-VII

537 Accessories | 3E^{TECH} Accessories | Clamping Pieces

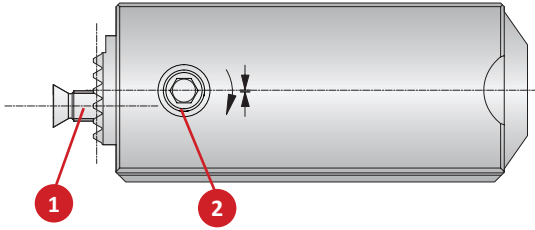

537 Analogue Cassette

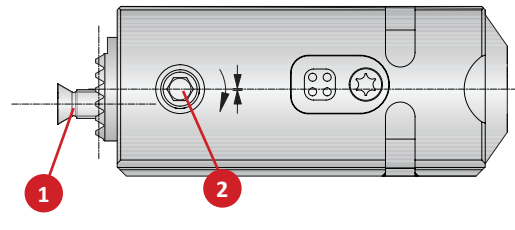

537 3E^{TECH} Cassette

537 Accessories

Cassette Part No.	1 Countersunk Screw		2 Clamping Screw	
	Part No.	Service Key	Part No.	Service Key
537051	215462	T20 / H	115249	s4 / F
537052	215462	T20 / H	315789	s4 / F

3E^{TECH} Accessories

1
Charging Unit
Part No.
536016



NOTE: Charging unit sold separately from 3E^{TECH}

NOTE: 3E^{TECH} adjustment accuracy of 0.0001" or 0.001 mm on diameter

3E^{TECH} Accessories (Old Display)

1	2
Sealing Ring	Battery CR2032
Part No.	Part No.
215483	515491

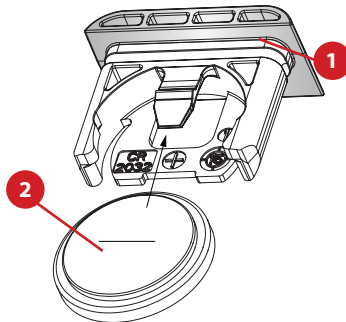

NOTE: Not required for 3E^{TECH} (New Display)

537 Clamping Pieces

Slide Type	Complete Part No.	Service Key		Replacement Components		
				1 Cap Screw	2 Clamping Nut	3 Disk Spring
Serrated Tool Bodies	137026	115578	s6 / B	215101	140118	337105
Basic and Eco Slides	137027			215102	215105	337105
Flex Slides	137019			415900	215105	337105

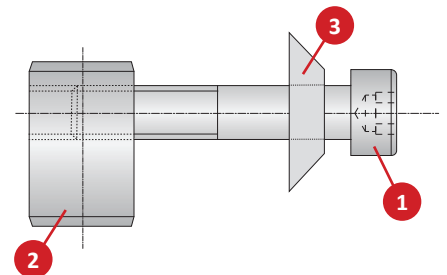

NOTE: Clamping pieces sold separately

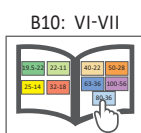
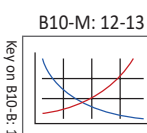

 = Metric (mm)
Inserts sold separately

A
B
C
D
E
F
G
H
I
J
K
L
M
INDEX

SECTION

B10-C

Combi-Line Rough and Finish Boring

Wohlhaupter® Rough and Finish Boring

Combi-Line

► Diameter Range: 24.50 mm - 201.00 mm



One tool. Two operations.

The Wohlhaupter Combi-Line combines both rough and finish boring into one operation. The front insert holder is the roughing cutting edge while the shorter holder finishes the hole, saving you time and money.

Your safety and the safety of others is very important. This catalogue contains important safety messages. Always read and follow all safety precautions.



This triangle is a safety hazard symbol. It alerts you to potential safety hazards that can cause tool failure and serious injury.

When you see this symbol in the catalogue, look for a related safety message that may be near this triangle or referred to in the nearby text.

There are safety signal words also used in the catalogue. Safety messages follow these words.

WARNING (shown above) means that failure to follow the precautions in this message could result in tool failure and serious injury.

NOTICE means that failure to follow the precautions in this message could result in damage to the tool or machine but not result in personal injury.

NOTE and **IMPORTANT** are also used. These are important that you read and follow but are not safety-related.

Visit www.alliedmachine.com for the most up-to-date information and procedures.

Applicable Industries



Aerospace



Agriculture



Automotive



Firearms



General
Machining



Oil & Gas



Renewable
Energy

Combi-Line Rough and Finish Boring Table of Contents

Reference Icons

The following icons will appear throughout the catalogue to help you navigate between products.

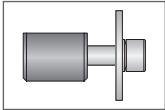

Clamping Elements

For use with insert holders and boring heads

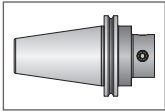

Shanks

A variety of shanks for different machines

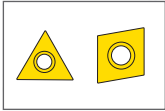

Inserts

For use with insert holder boring heads and boring bars using indexable inserts

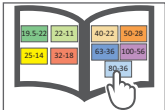

MVS Connection Colour Guide

Detailed instructions and information regarding the MVS connection(s)

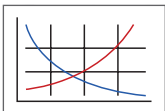

Recommended Cutting Data

Speed and feed recommendations for optimum and safe boring



Through Coolant Option

Indicates that the product is through coolant

Combi-Line Introduction

Product Overview	2 - 3
Material Removal Percentages Tool Usage Same Level Cutting	4
Boring Heads and Insert Holders	5
90° and 95° Approach Angle Same Level Insert Holders - Form 101, 103	6
Accessories	7

Series	Diameter Range
	Metric (mm)
Combi-Line 401	24.50 - 201.00

Combi-Line Product Overview

Combi-Line ROUGH & FINISH BORING

Two Operations. One Tool.

Decrease cycle time and tool changes with the Wohlhaupter Combi-Line. The Combi-Line combines rough and finish boring into one tool with height displaced insert holders.

Reduce your *cycle time* with the Combi-Line.

- Diameter range: 24.50 mm - 201.00 mm
- Reduce cycle and tool changing time
- Available in semi-standard same level or height displaced insert holders
- Through coolant
- 0.002 mm vernier adjustment on finishing insert holder
- Max spindle speed: 1524 m/min



IMPORTANT: Max spindle speed refers to maximum possible speed for an individual boring head and is not a recommended parameter. Refer to page B10-M: 12 for recommended application-specific parameters. Factory technical assistance is available for your specific applications through our Application Engineering department.
email: engineering.eu@alliedmachine.com

Cycle time is crucial. Why not choose the best process?

Application: Ductile Cast Iron

Finish Diameter: 50 mm (+/- 0.013 mm)

Pre-Hole Diameter: 45 mm

Boring Depth: 209 mm

Hole Finish: 0.8 Ra



Measure	1st Process Option	
	Step 1 Rough 49 mm Competitor 1.5" High Feed Milling Tool	Step 2 Finish 50 mm Wohlhaupter 310 Boring Head
Speed	2500 RPM	1165 PRM
Feed Rate	3886.2 mm/min	11.8 mm/min
Total Passes	77	1
Cycle Time (per hole)	1.93 min	1.77 min
Tool Change Time	15 sec	
Cycle Time (per part)	3 min 54 sec	

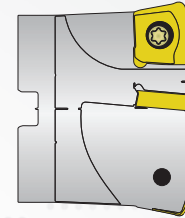

1.5" High Feed Milling Tool



Wohlhaupter 310 Boring Head

Measure	2nd Process Option	
	Step 1 Rough 49 mm Wohlhaupter Twin Cutter at 49 mm Ø	Step 2 Finish 50 mm Wohlhaupter 310 Boring Head
Speed	990 RPM	1165 PRM
Feed Rate	301.88 mm/min	11.8 mm/min
Total Passes	1	1
Cycle Time (per hole)	0.69 min	1.77 min
Tool Change Time	15 sec	
Cycle Time (per part)	2 min 46 sec	



Wohlhaupter Twin Cutter



Wohlhaupter 310 Boring Head

OUR **SOLUTION** Combi-Line Rough and Finish Boring

Measure	3rd Process Option Finish 50 mm Wohlhaupter Combi-Line
Speed	1165 RPM
Feed Rate	11.8 mm/min
Total Passes	1
Cycle Time (per hole)	1.77 min
Tool Change Time	0
Cycle Time (per part)	1 min 46 sec

- ▶ Combi-Line assembly:
 - (1) Insert holders (x2): 402021
 - (2) Serrated tool body: 404006
 - (3) Shank: 353014

- Boring inserts
 - ▶ Item No. 297653WHC19



60 seconds of total cycle time saved



1 tool vs. 2 tools saves you time and money

Material Removal Percentages | Tool Usage | Same-Level Cutting

Material Removal Percentages

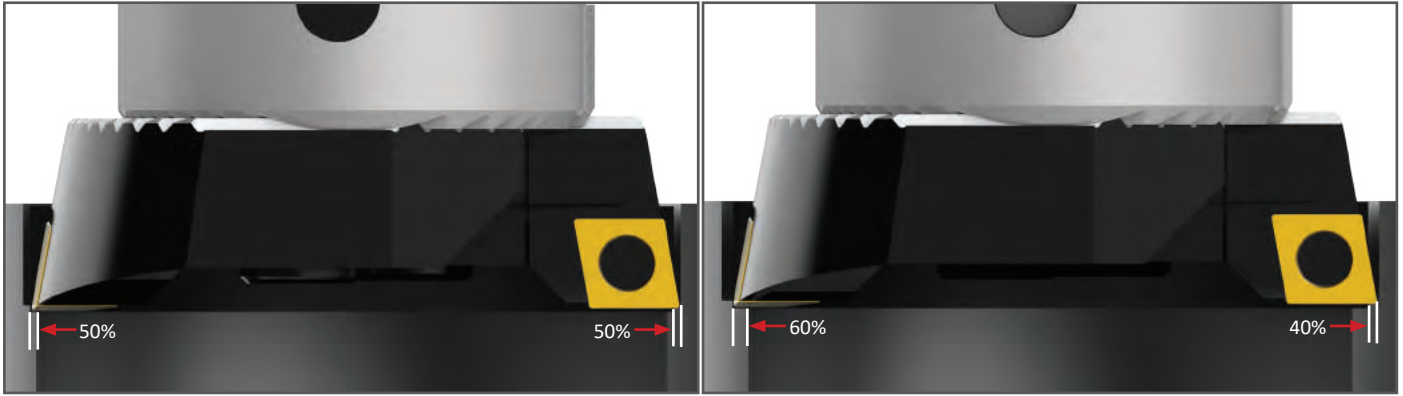

Material removal up to 4.00 mm on diameter: **50% roughing 50% finishing**

Material removal up to 4.00 mm - 7.00 mm on diameter: **60% roughing 40% finishing**

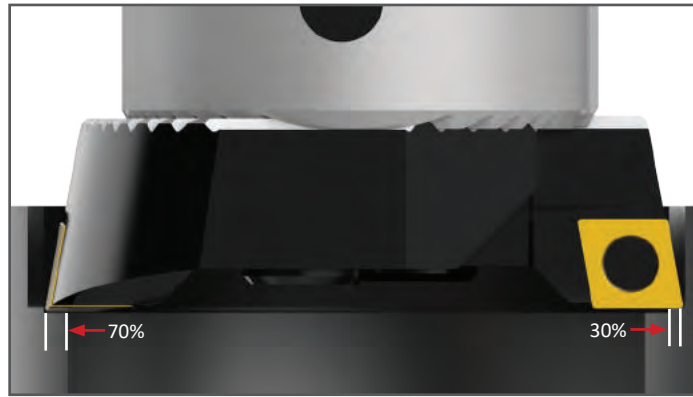

Material removal up to 7.00 mm - 10.00 mm on diameter: **70% roughing 30% finishing**

- For tools with a length-to-diameter ratio greater than 4:1, the existing hole diameter should be no more than 4.00 mm smaller than the finish diameter. The 50% roughing and 50% finishing rule should be applied.
- When boring with severe interruptions, the existing hole diameter should be no more than 4.00 mm smaller than the finish diameter. The 50% roughing and 50% finishing rule should be applied.

IMPORTANT: Consult application engineering for technical support when using Combi-Line tools in holes with interruptions.
 email: engineering.eu@alliedmachine.com

Tool Usage

- For most applications, the same inserts should be used in both the roughing and finishing insert holders.
- To insure proper chip breaking, the finishing insert holder DOC must be at least 0.50 mm
- Up to a 4:1 length-to-diameter ratio, standard insert holders with a height displacement of up to 0.30 mm can be used.
- Inserts with wiper geometry are recommended only for special Combi-Line applications.

Same-Level Cutting (0.08 mm Height Displacement)

- With length-to-diameter ratios greater than 4:1, same-level insert holders are recommended to reduce the risk of vibration.
- Same-level cutting inserts will create a 0.08 mm step between the roughing and finishing sides.
- Boring blind holes may require the use of same-level insert holders. (If a true 90° flat bottom is required, a secondary operation to clean up the bottom step may be needed.)
- Combi-Line should be applied as a single-effective cutting tool even when same-level insert holders are used.

Boring Heads and Insert Holders

Diameter Range: 24.50 mm - 201.00 mm



COMBI LINE

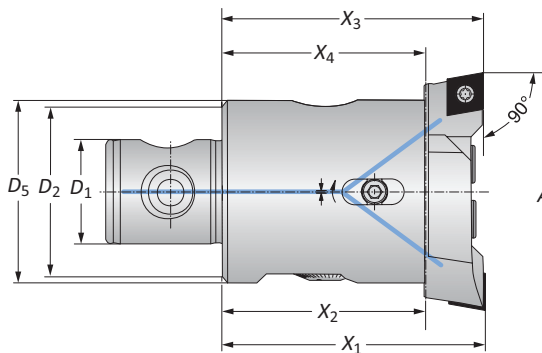

Connection	Boring Range	Boring Head					Weight	Insert Form	Part No.		
		$D_2 D_1$	A	X_1	X_3	X_2			X_4	D_5	(x2)* Insert Holder**
	22 - 11	24.50 - 29.50	46.00	45.75	34.00	33.75	-	0.10 (kg)	101	402029	401003
	25 - 14	29.00 - 37.00	56.00	55.75	41.00	40.75	26.00	0.20 (kg)	101	402009	401004
	25 - 14	29.00 - 37.00	56.00	55.75	41.00	40.75	26.00	0.20 (kg)	103	402011	401004
	25 - 14	36.00 - 44.00	56.00	55.75	41.00	40.75	30.00	0.30 (kg)	101	402017	401005
	25 - 14	36.00 - 44.00	56.00	55.75	41.00	40.75	30.00	0.30 (kg)	103	402019	401005
	32 - 18	43.00 - 54.00	66.00	65.70	48.00	47.70	34.00	0.40 (kg)	103	402021	401006
	40 - 22	53.00 - 66.00	75.00	74.70	55.00	54.70	-	0.70 (kg)	103	402005	401007
	50 - 28	65.00 - 83.00	75.00	74.70	55.00	54.70	-	1.10 (kg)	103	402013	401008
	63 - 36	82.00 - 103.00	90.00	89.70	70.00	69.70	-	2.20 (kg)	103	402001	401009
	80 - 36	102.00 - 127.00	90.00	89.70	66.00	65.70	85.00	3.00 (kg)	103	402025	401010
	80 - 36	127.00 - 152.00	90.00	89.70	66.00	65.70	85.00	3.10 (kg)	103	402026	401010
	80 - 36	151.00 - 176.00	90.00	89.70	66.00	65.70	134.00	3.80 (kg)	103	402025	401011
	80 - 36	176.00 - 201.00	90.00	89.70	66.00	65.70	134.00	3.90 (kg)	103	402026	401011

*(2) insert holders are required
 **Insert holders sold individually

Key on B10-C-1

B10-M: 12-13

B10-C: 6

B10-F

B10-H

B10: VI-VII

 = Metric (mm)

Inserts sold separately

IMPORTANT: Max spindle speed refers to maximum possible speed for an individual boring head and is not a recommended parameter. Refer to page B10-M: 12 for recommended application-specific parameters. Factory technical assistance is available for your specific applications through our Application Engineering department.
 email: engineering.eu@alliedmachine.com

90° and 95° Approach Angle Same Level Insert Holders - Form 101 and 103

Diameter Range: 0.965" - 7.913" (24.51mm - 200.90mm)

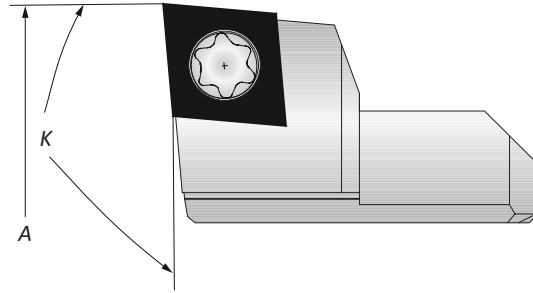
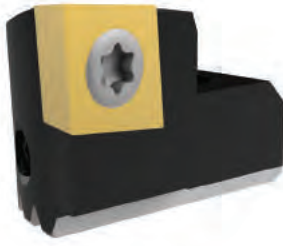

Boring Tool	Boring Range A	90° Insert Holder			95° Insert Holder		
		K	Insert Form	Part No.	K	Insert Form	Part No.
401003	24.51 - 29.48	90°	101	K32616	95°	101	K32618
401004	29.00 - 37.00	90°	103	K31372	95°	103	K31403
401005	35.99 - 43.99	90°	103	K31373	95°	103	K31404
401006	43.00 - 54.00	90°	103	K31374	95°	103	K31405
401007	53.00 - 65.98	90°	103	K31375	95°	103	K31406
401008	64.99 - 83.00	90°	103	K31376	95°	103	K31407
401009	81.99 - 102.90	90°	103	K31377	95°	103	K31408
401010	102.00 - 127.00	90°	103	K31628	95°	103	K31632
401010	127.00 - 151.90	90°	103	K31630	95°	103	K31634
401011	151.00 - 200.90	90°	103	K31628	95°	103	K31632
401011	175.90 - 200.90	90°	103	K31630	95°	103	K31634

NOTE: Same level insert holders will still produce a 0.003" (0.0001 mm) step

B10-M: 12-13 B10-H B10: VI-VII

m = Metric (mm)
Inserts sold separately

Accessories

Screws | Clamping Elements

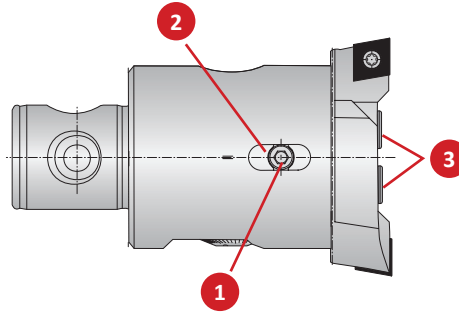

Boring Head Part No.	Part No.				
	1 Clamp Screw	Service Key	2 Clamping Piece	3 Cap Screw	Service Key
401003	401223	s2.5 / A	–	401323	s3 / B
401004	401224	s2.5 / B	401204	401324	s4 / B
401005	401225	s2.5 / B	401205	401324	s4 / B
401006	401226	s3 / B	401206	401324	s4 / B
m 401007	401227	s3 / B	401207	401327	s5 / B
401008	115288	s4 / B	401208	401329	s6 / B
401009	215501	s4 / B	401209	401329	s6 / B
401010	401230	s4 / B	401210	019183	s8 / C
401011	401230	s4 / B	401210	019183	s8 / C

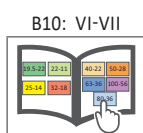
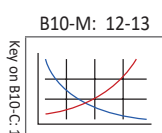

SECTION

B10-D

Rough Machining

Wohlhaupter® Rough Machining

Twin Cutters | Chamfering Tools | Grooving Tools | Axial Grooving | Reverse Machining | VolCut

▶ Diameter Range: 19.50 mm - 245.00 mm



Variety of tooling. Versatile operations.

A versatile range of tools for rough machining includes rough boring, chamfering, reverse machining, circular milling, and axial grooving. The insert holders with various insert pockets as well as height displaced insert holders are able to be easily adjusted for a quick setup process.

Your safety and the safety of others is very important. This catalogue contains important safety messages. Always read and follow all safety precautions.



This triangle is a safety hazard symbol. It alerts you to potential safety hazards that can cause tool failure and serious injury.

When you see this symbol in the catalogue, look for a related safety message that may be near this triangle or referred to in the nearby text.

There are safety signal words also used in the catalogue. Safety messages follow these words.



WARNING (shown above) means that failure to follow the precautions in this message could result in tool failure and serious injury.

NOTICE means that failure to follow the precautions in this message could result in damage to the tool or machine but not result in personal injury.

NOTE and **IMPORTANT** are also used. These are important that you read and follow but are not safety-related.

Visit www.alliedmachine.com for the most up-to-date information and procedures.

Applicable Industries



Aerospace



Agriculture



Automotive



Firearms



General
Machining



Oil & Gas



Renewable
Energy

Rough Machining Table of Contents

Reference Icons

The following icons will appear throughout the catalogue to help you navigate between products.

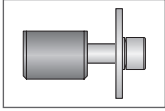

Clamping Elements

For use with insert holders and boring heads

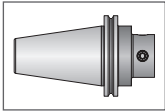

Shanks

A variety of shanks for different machines

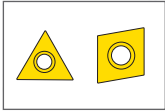

Inserts

For use with insert holder boring heads and boring bars using indexable inserts

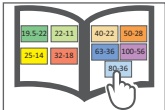

MVS Connection Colour Guide

Detailed instructions and information regarding the MVS connection(s)

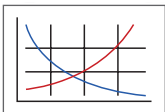

Recommended Cutting Data

Speed and feed recommendations for optimum and safe boring



Though Coolant Option

Indicates that the product is through coolant

Introduction

Product Overview 2 - 4

Twin Cutters

Twin Cutters Same Level 5 - 9

Twin Cutters Same Level Tangential Inserts 10

Twin Cutters Height Displaced 11 - 13

Twin Cutters Height Displaced Tangential Inserts 14

Chamfering

Chamfering Tools 15 - 17

Grooving

Grooving Tools for Circular Milling 18

Axial Grooving Tools 19

Reverse Machining

Reverse Machining Tools 20

VolCut Tooling

VolCut Insert Holders 21

VolCut Technical Information 22

Accessories 23

Series	Diameter Range
	Metric (mm)
Twin Cutters	19.50 - 205.00
Chamfering	19.00 - 216.00
Radial Grooving	20.00 - 79.00
Axial Grooving	20.00 - 205.00
Reverse Machining	29.00 - 245.00

Rough Machining Product Preview

Roughing Tools ROUGH MACHINING

Versatile tools for a variety of applications.

- Diameter range: 19.50 mm - 245.00 mm
- Tangential inserts and insert holders also available
- Serrated tool bodies can be used for multiple applications including rough boring, chamfering, back boring, and axial grooving
- Insert holders can be used on large diameter Alu-Line serrated tool bodies and slides located in section G: 100.00 mm - 3255.00 mm

Roughing Applications



- ▶ **Twin Cutter Assembly:**
- (1) Reducer: 219087
 - (2) Serrated tool body: 148004
 - (3) Insert holders: 151004
 - (4) Inserts: 10408M158HC79



- ▶ **Tangential Cutter Assembly:**
- (1) Shank: 353007
 - (2) Serrated tool body: 148005
 - (3) Insert holders: 151043
 - (4) Inserts: 00508M880HC198

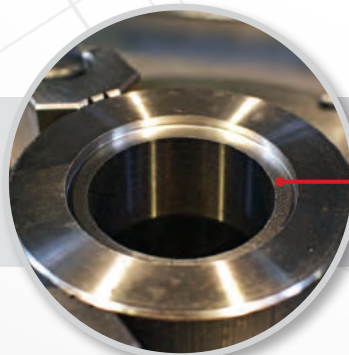

First Tangential Cut



▶ **Tangential Cutter Assembly:**

- (1) Shank: 353008
- (2) Serrated tool body: 148006
- (3) Insert holders: 151035
- (4) Inserts: 397594WHC198

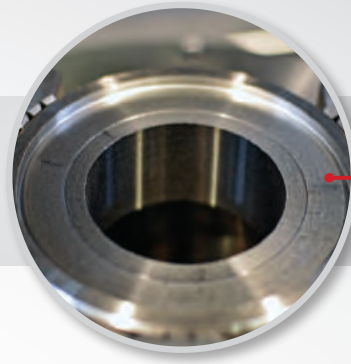

Second Tangential Cut



▶ **Axial Grooving Assembly:**

- (1) Shank: 353009
- (2) Serrated tool body: 148007
- (3) Support block: 226011
- (4) Insert holder: 226010
- (5) Insert: 297978WCH136

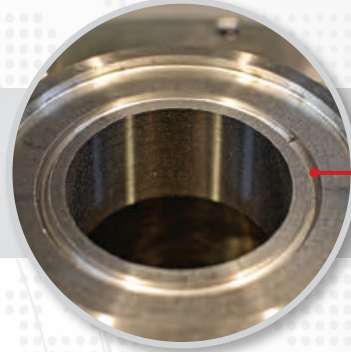

Axial Groove Cut



▶ **Chamfer Assembly:**

- (1) Shank: 353003
- (2) Serrated tool body: 148004
- (3) Insert holder: 201009
- (4) Inserts: 297497WHC79

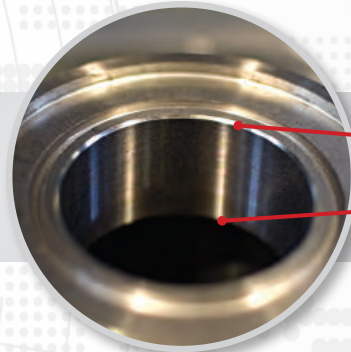

Top Chamfer

Bottom Chamfer



▶ **Radial Grooving Assembly:**

- (1) Shank: 353007
- (2) Grooving tool: 143055
- (3) Inserts: 097254WCH136

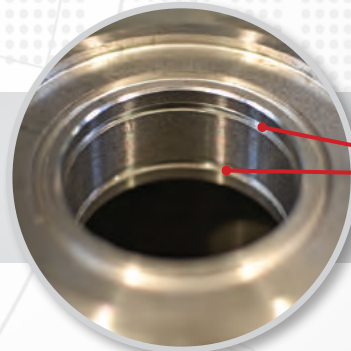

Grooves



▶ **Finished Application**

Case Study

Cycle time is crucial. Why not choose the best process?

Application: Ductile Cast Iron

Finish Diameter: 49 mm

Pre-Hole Diameter: 45 mm

Boring Depth: 209 mm



Measure	Rough 49 mm Competitor 1.5" High Feed Milling Tool
Speed	2500 RPM
Feed Rate	3886.2 mm/min
Total Passes	77
Cycle Time (per part)	1.93 min

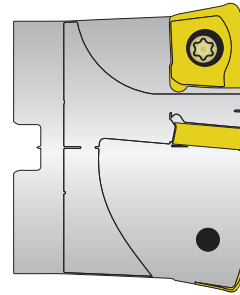

1.5" High Feed Milling Tool

OUR **SOLUTION**
Wohlhaupter® Twin Cutter

Measure	Rough 49 mm Wohlhaupter Twin Cutter
Speed	900 RPM
Feed Rate	301.8 mm/min
Total Passes	1
Cycle Time (per part)	0.69 min

- ▶ Twin Cutter assembly:
 - (1) *Insert Holders (x2): 151023*
 - (2) *Serrated tool body: 148018*
 - (3) *Shank: 353015*

- Boring inserts
- ▶ *Item No.: 297239WHC79*

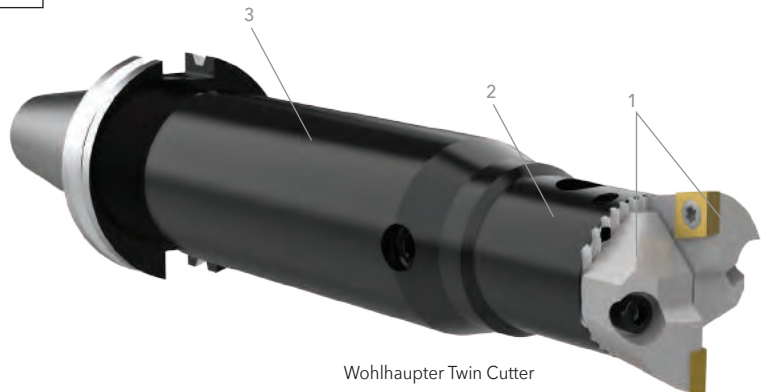

Wohlhaupter Twin Cutter

Twin Cutters Same Level

90° | Diameter Range: 19.50 mm - 30.00 mm

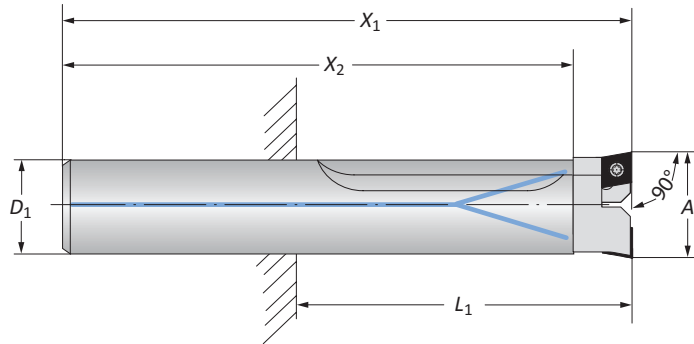
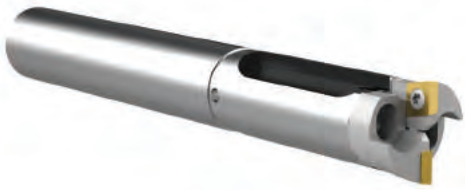

Twin Cutters Same Level

Connection	Boring Range	Twin Cutter			Weight	Insert Form	Part No.	
		X_1	X_2	L_1			Insert Holder	Serrated Body
D_1	A							
18	19.50 - 23.00	150.00	138.00	80.00	0.30 (kg)	101	235031	235021
20	22.50 - 26.00	150.00	138.00	90.00	0.30 (kg)	101	235032	235022
23	25.50 - 30.00	160.00	148.00	100.00	0.30 (kg)	101	235033	235023

NOTE: Insert holders sold in quantities of 1, and inserts sold separately

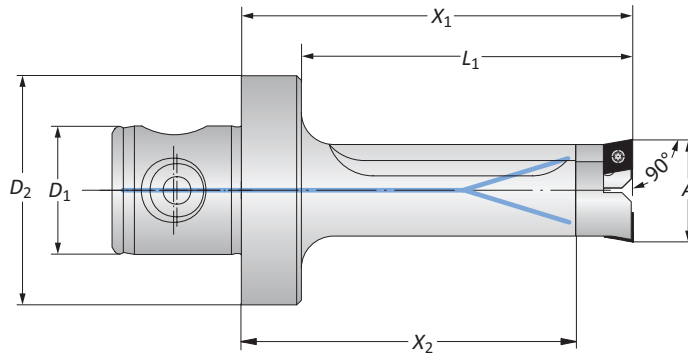

Twin Cutters Same Level

Connection	Boring Range	Twin Cutter			Weight	Insert Form	Part No.	
		X_1	X_2	L_1			Insert Holder	Serrated Body
D_2 D_1	A							
50 - 28	19.50 - 23.00	85.00	73.00	72.00	0.40 (kg)	101	235031	235001
50 - 28	22.50 - 26.00	90.00	78.00	77.00	0.50 (kg)	101	235032	235002
50 - 28	25.50 - 30.00	95.00	83.00	82.00	0.50 (kg)	101	235033	235003
63 - 36	19.50 - 23.00	85.00	73.00	72.00	0.70 (kg)	101	235031	235011
63 - 36	22.50 - 26.00	90.00	78.00	77.00	0.70 (kg)	101	235032	235012
63 - 36	25.50 - 30.00	95.00	83.00	82.00	0.83 (kg)	101	235033	235013

NOTE: Insert holders sold in quantities of 1, and inserts sold separately

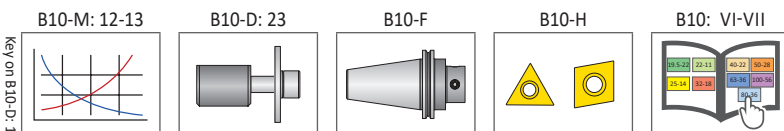

m = Metric (mm)

Inserts sold separately

IMPORTANT: Max spindle speed refers to maximum possible speed for an individual boring head and is not a recommended parameter. Refer to page B10-M: 12 for recommended application-specific parameters. Factory technical assistance is available for your specific applications through our Application Engineering department.
 email: engineering.eu@alliedmachine.com

Twin Cutters Same Level

90° | 5xD | Diameter Range: 29.00 mm - 66.00 mm

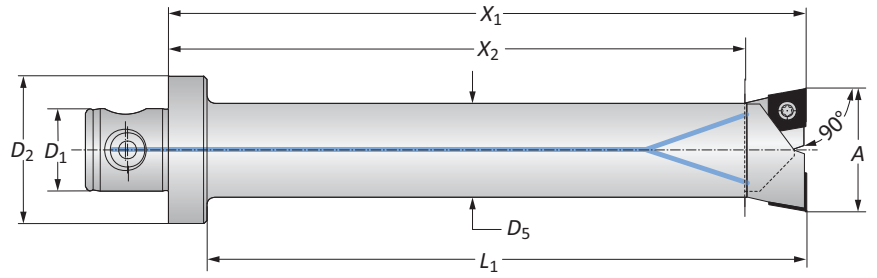

Connection	Boring Range	Twin Cutter				Weight	Insert Form	Part No.		
		$D_2 D_1$	A	X_1	X_2			L_1	D_5	Insert Holder
M	50 - 28	29.00 - 37.00	155.00	141.00	142.00	26.00	0.90 (kg)	103	151001	148021
	50 - 28	36.00 - 44.00	175.00	161.00	162.00	32.00	1.30 (kg)	103	151002	148022
	50 - 28	43.00 - 54.00	215.00	195.00	202.00	37.00	1.90 (kg)	103	151023	148023
	50 - 28	43.00 - 54.00	215.00	195.00	202.00	37.00	1.90 (kg)	104	151003	148023
	50 - 28	53.00 - 66.00	215.00	195.00	202.00	44.00	2.50 (kg)	103	151024	148024
	50 - 28	53.00 - 66.00	215.00	195.00	202.00	44.00	2.50 (kg)	104	151004	148024

NOTE: Different lengths available upon request.

NOTE: Insert holders sold in quantities of 1, and inserts sold separately

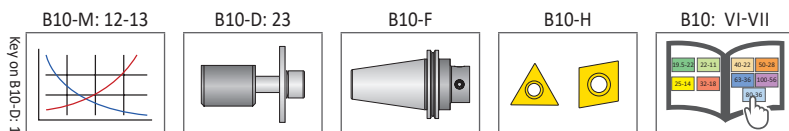

M = Metric (mm)

Inserts sold separately

IMPORTANT: Max spindle speed refers to maximum possible speed for an individual boring head and is not a recommended parameter. Refer to page B10-M: 12 for recommended application-specific parameters. Factory technical assistance is available for your specific applications through our Application Engineering department.
 email: engineering.eu@alliedmachine.com

Twin Cutters Same Level

90° | Diameter Range: 29.00 mm - 103.00 mm

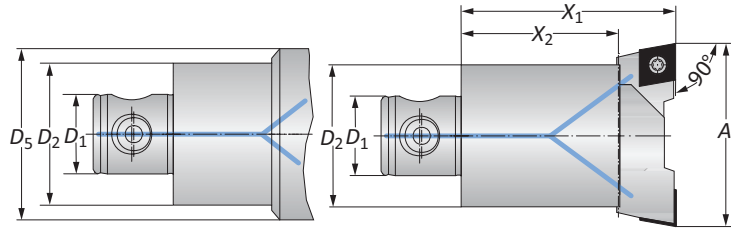

Connection	Boring Range	Twin Cutter			Weight	Insert Form	Part No.		
		$D_2 D_1$	A	X_1			X_2	D_5	Insert Holder
M	25 - 14	29.00 - 37.00	56.00	42.00	-	0.20 (kg)	103	151001	148001
	25 - 14	36.00 - 44.00	56.00	42.00	30.00	0.20 (kg)	103	151002	148002
	32 - 18	36.00 - 44.00	56.00	42.00	30.00	0.40 (kg)	103	151002	148017
	32 - 18	43.00 - 54.00	66.00	46.00	36.00	0.40 (kg)	103	151023	148003
	32 - 18	43.00 - 54.00	66.00	46.00	36.00	0.40 (kg)	104	151003	148003
	40 - 22	43.00 - 54.00	66.00	46.00	36.00	0.70 (kg)	103	151023	148018
	40 - 22	43.00 - 54.00	66.00	46.00	36.00	0.70 (kg)	104	151003	148018
	40 - 22	53.00 - 66.00	75.00	55.00	-	0.70 (kg)	103	151024	148004
	40 - 22	53.00 - 66.00	75.00	55.00	-	0.70 (kg)	104	151004	148004
	50 - 28	65.00 - 83.00	75.00	55.00	-	1.10 (kg)	103	151025	148005
	50 - 28	65.00 - 83.00	75.00	55.00	-	1.10 (kg)	104	151005	148005
	63 - 36	82.00 - 103.00	90.00	60.00	-	1.90 (kg)	103	151026	148006
	63 - 36	82.00 - 103.00	90.00	60.00	-	1.90 (kg)	104	151086	148006
	63 - 36	82.00 - 103.00	90.00	60.00	-	1.90 (kg)	105	151006	148006

NOTE: Insert holders sold in quantities of 1, and inserts sold separately

Key on B10-D-1

B10-M: 12-13

B10-D: 23

B10-F

B10-H

B10: VI-VII

M = Metric (mm)

Inserts sold separately

IMPORTANT: Max spindle speed refers to maximum possible speed for an individual boring head and is not a recommended parameter. Refer to page B10-M: 12 for recommended application-specific parameters. Factory technical assistance is available for your specific applications through our Application Engineering department.
 email: engineering.eu@alliedmachine.com

Twin Cutters Same Level

90° | Diameter Range: 100.00 mm - 205.00 mm

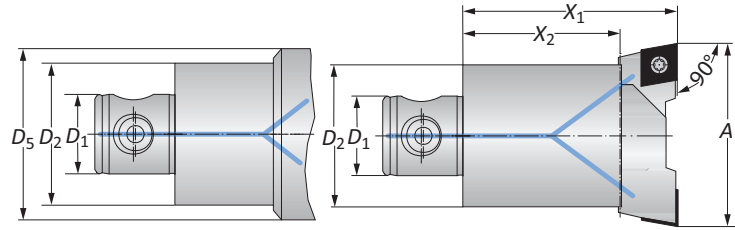

Connection	Boring Range	Twin Cutter			Weight	Insert Form	Part No.		
		$D_2 D_1$	A	X_1			X_2	D_5	Insert Holder
m	80 - 36	100.00 - 130.00	90.00	60.00	–	3.00 (kg)	103	151027	148007
	80 - 36	100.00 - 130.00	90.00	60.00	–	3.00 (kg)	104	151087	148007
	80 - 36	100.00 - 130.00	90.00	60.00	–	3.00 (kg)	105	151007	148007
	80 - 36	125.00 - 155.00	90.00	60.00	–	3.20 (kg)	103	151028	148007
	80 - 36	125.00 - 155.00	90.00	60.00	–	3.20 (kg)	104	151088	148007
	80 - 36	125.00 - 155.00	90.00	60.00	–	3.20 (kg)	105	151008	148007
	80 - 36	150.00 - 205.00	90.00	60.00	125.00	4.00 (kg)	103	151028	148009
	80 - 36	150.00 - 205.00	90.00	60.00	125.00	4.00 (kg)	104	151088	148009
	80 - 36	150.00 - 205.00	90.00	60.00	125.00	4.00 (kg)	105	151008	148009

NOTE: Insert holders sold in quantities of 1, and inserts sold separately

Key on B10-D-1

B10-M: 12-13

B10-D: 23

B10-F

B10-H

B10: VI-VII

m = Metric (mm)

Inserts sold separately

IMPORTANT: Max spindle speed refers to maximum possible speed for an individual boring head and is not a recommended parameter. Refer to page B10-M: 12 for recommended application-specific parameters. Factory technical assistance is available for your specific applications through our Application Engineering department.
 email: engineering.eu@alliedmachine.com

Twin Cutters Same Level

80° | Diameter Range: 29.00 mm - 205.00 mm

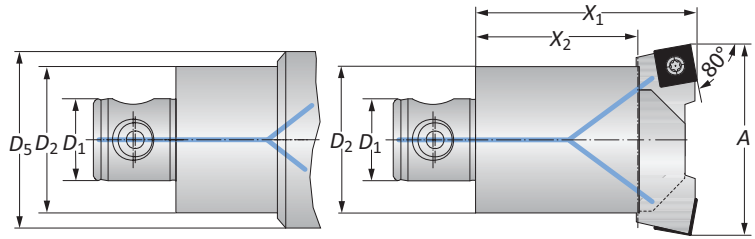

Connection	Boring Range	Twin Cutter			Weight	Insert Form	Part No.		
		D_2 D_1	A	X_1			X_2	D_5	Insert Holder
m	25 - 14	29.00 - 37.00	56.00	42.00	–	0.20 (kg)	112	151011	148001
	25 - 14	36.00 - 44.00	56.00	42.00	30.00	0.20 (kg)	112	151012	148002
	32 - 18	36.00 - 44.00	62.00	42.00	30.00	0.40 (kg)	112	151012	148017
	32 - 18	43.00 - 54.00	66.00	46.00	36.00	0.40 (kg)	113	151013	148003
	40 - 22	43.00 - 54.00	66.00	46.00	36.00	0.70 (kg)	113	151013	148018
	40 - 22	53.00 - 66.00	75.00	55.00	–	0.70 (kg)	113	151014	148004
	50 - 28	65.00 - 83.00	75.00	55.00	–	1.10 (kg)	113	151015	148005
	63 - 36	82.00 - 103.00	90.00	60.00	–	2.30 (kg)	113	151036	148006
	80 - 36	100.00 - 130.00	90.00	60.00	–	3.00 (kg)	113	151037	148007
	80 - 36	125.00 - 155.00	90.00	60.00	–	3.20 (kg)	113	151038	148007
80 - 36	150.00 - 205.00	90.00	60.00	125.00	4.00 (kg)	113	151038	148009	

NOTE: Insert holders sold in quantities of 1, and inserts sold separately

Key on B10-D-1

B10-M: 12-13

B10-D: 23

B10-F

B10-H

B10: VI-VII

m = Metric (mm)

Inserts sold separately

IMPORTANT: Max spindle speed refers to maximum possible speed for an individual boring head and is not a recommended parameter. Refer to page B10-M: 12 for recommended application-specific parameters. Factory technical assistance is available for your specific applications through our Application Engineering department.
 email: engineering.eu@alliedmachine.com

Twin Cutters Same Level Tangential Inserts

Diameter Range: 53.00 mm - 205.00 mm

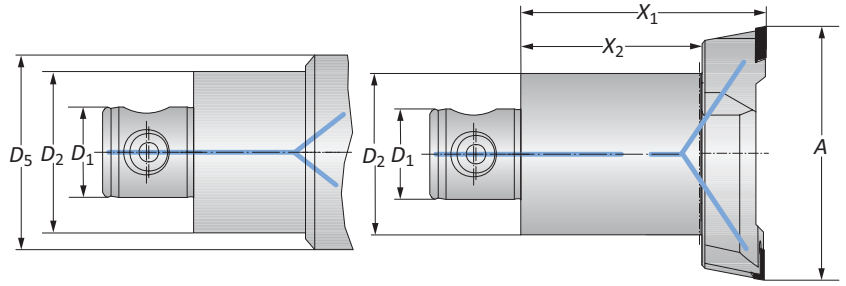

Connection	Boring Range	Twin Cutter			Weight	Insert Form	Part No.		
		D_2 D_1	A	X_1			X_2	D_5	Insert Holder
M	40 - 22	53.00 - 66.00	75.00	55.00	-	0.70 (kg)	04	151022	148004
	50 - 28	65.00 - 83.00	75.00	55.00	-	1.00 (kg)	04	151032	148005
	50 - 28	65.00 - 83.00	75.00	55.00	-	1.00 (kg)	05	151043	148005
	63 - 36	82.00 - 103.00	90.00	60.00	-	2.20 (kg)	05	151035	148006
	80 - 36	100.00 - 130.00	90.00	60.00	-	3.00 (kg)	05	151009	148007
	80 - 36	125.00 - 155.00	90.00	60.00	-	3.10 (kg)	05	151010	148007
	80 - 36	150.00 - 205.00	90.00	60.00	125.00	4.00 (kg)	05	151010	148009

NOTE: Insert holders sold in quantities of 1, and inserts sold separately

Key on B10-D-1

B10-M: 12-13

B10-D: 23

B10-F

B10-H

B10: VI-VII

M = Metric (mm)

Inserts sold separately

IMPORTANT: Max spindle speed refers to maximum possible speed for an individual boring head and is not a recommended parameter. Refer to page B10-M: 12 for recommended application-specific parameters. Factory technical assistance is available for your specific applications through our Application Engineering department.
 email: engineering.eu@alliedmachine.com

Twin Cutters Height Displaced

90° | Diameter Range: 29.00 mm - 103.00 mm

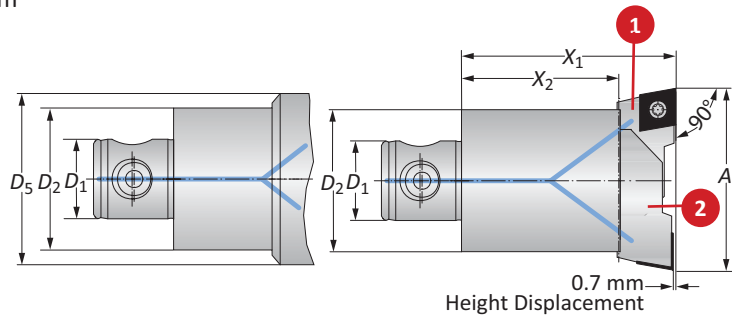

Connection	Boring Range	Twin Cutter			Weight	Insert Form	Part No.			
		$D_2 D_1$	A	X_1			X_2	D_5	1 Insert Holder	2. Insert Holder (-0.7 mm)
	25 - 14	29.00 - 37.00	56.00	42.00	–	0.20 (kg)	103	151001	151061	148001
	25 - 14	36.00 - 44.00	56.00	42.00	30.00	0.20 (kg)	103	151002	151062	148002
	32 - 18	36.00 - 44.00	56.00	42.00	30.00	0.40 (kg)	103	151002	151062	148017
	32 - 18	43.00 - 54.00	66.00	46.00	36.00	0.40 (kg)	104	151003	151093	148003
	40 - 22	43.00 - 54.00	66.00	46.00	36.00	0.70 (kg)	104	151003	151093	148018
	40 - 22	53.00 - 66.00	75.00	55.00	–	0.70 (kg)	104	151004	151094	148004
	50 - 28	65.00 - 83.00	75.00	55.00	–	1.10 (kg)	104	151005	151095	148005
	63 - 36	82.00 - 103.00	90.00	60.00	–	2.40 (kg)	104	151086	151090	148006
	63 - 36	82.00 - 103.00	90.00	60.00	–	2.40 (kg)	105	151006	151096	148006

NOTE: Insert holders sold in quantities of 1, and inserts sold separately

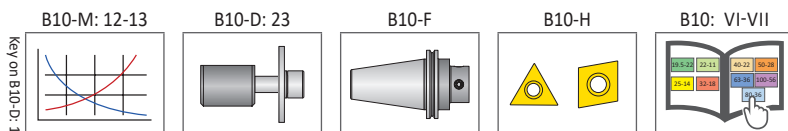

 = Metric (mm)

Inserts sold separately

IMPORTANT: Max spindle speed refers to maximum possible speed for an individual boring head and is not a recommended parameter. Refer to page B10-M: 12 for recommended application-specific parameters. Factory technical assistance is available for your specific applications through our Application Engineering department.
 email: engineering.eu@alliedmachine.com

Twin Cutters Height Displaced

90° | 5xD | Diameter Range: 29.00 mm - 66.00 mm

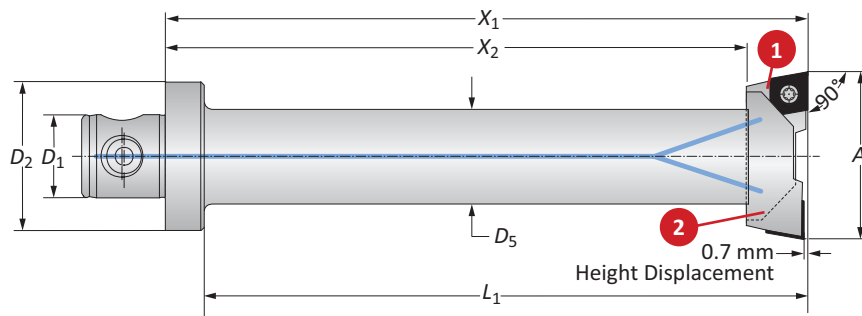

Connection	Boring Range	Twin Cutter					Weight	Insert Form	Part No.		
		D_2 D_1	A	X_1	X_2	L_1			D_5	1. Insert Holder	2. Insert Holder (-0.7 mm)
m	50 - 28	29.00 - 37.00	155.00	141.00	142.00	26.00	0.90 (kg)	103	151001	151061	148021
	50 - 28	36.00 - 44.00	175.00	161.00	162.00	32.00	1.30 (kg)	103	151002	151062	148022
	50 - 28	43.00 - 54.00	215.00	195.00	202.00	37.00	1.90 (kg)	104	151003	151093	148023
	50 - 28	53.00 - 66.00	215.00	195.00	202.00	44.00	2.50 (kg)	104	151004	151094	148024

NOTE: Different lengths available upon request.

NOTE: Insert holders sold in quantities of 1, and inserts sold separately

Key on B10-D-1

B10-M: 12-13

B10-D: 23

B10-F

B10-H

B10: VI-VII

m = Metric (mm)

Inserts sold separately

IMPORTANT: Max spindle speed refers to maximum possible speed for an individual boring head and is not a recommended parameter. Refer to page B10-M: 12 for recommended application-specific parameters. Factory technical assistance is available for your specific applications through our Application Engineering department.
 email: engineering.eu@alliedmachine.com

Twin Cutters Height Displaced

90° | Diameter Range: 100.00 mm - 205.00 mm

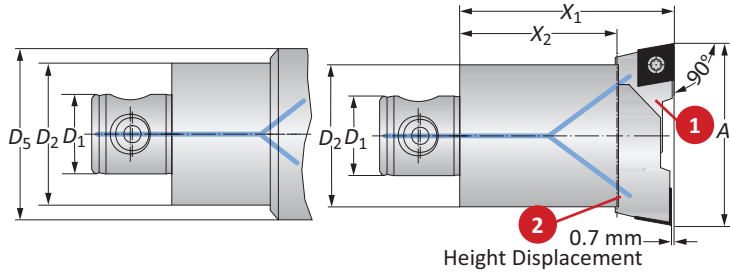

Connection	Boring Range	Twin Cutter			Weight	Insert Form	Part No.			
		$D_2 D_1$	A	X_1			X_2	D_5	1. Insert Holder	2. Insert Holder (-0.7 mm)
M	80 - 36	100.00 - 130.00	90.00	60.00	-	3.00 (kg)	104	151087	151091	148007
	80 - 36	100.00 - 130.00	90.00	60.00	-	3.00 (kg)	105	151007	151097	148007
	80 - 36	125.00 - 155.00	90.00	60.00	-	3.20 (kg)	104	151088	151092	148007
	80 - 36	125.00 - 155.00	90.00	60.00	-	3.20 (kg)	105	151008	151098	148007
	80 - 36	150.00 - 205.00	90.00	60.00	125.00	4.00 (kg)	104	151088	151092	148009
	80 - 36	150.00 - 205.00	90.00	60.00	125.00	4.00 (kg)	105	151008	151098	148009

NOTE: Insert holders sold in quantities of 1, and inserts sold separately

Key on B10-D-1

B10-M: 12-13

B10-D: 23

B10-F

B10-H

B10: VI-VII

M = Metric (mm)

Inserts sold separately

IMPORTANT: Max spindle speed refers to maximum possible speed for an individual boring head and is not a recommended parameter. Refer to page B10-M: 12 for recommended application-specific parameters. Factory technical assistance is available for your specific applications through our Application Engineering department.
 email: engineering.eu@alliedmachine.com

Twin Cutters Height Displaced Tangential Inserts

Diameter Range: 53.00 mm - 205.00 mm

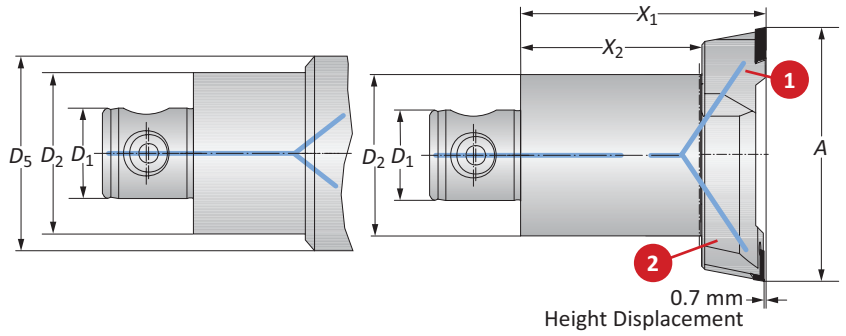

Connection	Boring Range	Twin Cutter			Weight	Insert Form	Part No.			
		$D_2 D_1$	A	X_1			X_2	D_5	1. Insert Holder	2. Insert Holder (-0.7 mm)
m	40 - 22	53.00 - 66.00	75.00	55.00	-	0.70 (kg)	04	151022	268009	148004
	50 - 28	65.00 - 83.00	75.00	55.00	-	1.00 (kg)	04	151032	268010	148005
	50 - 28	65.00 - 83.00	75.00	55.00	-	1.00 (kg)	05	151043	268019	148005
	63 - 36	82.00 - 103.00	90.00	60.00	-	2.20 (kg)	04	151034	268020	148006
	63 - 36	82.00 - 103.00	90.00	60.00	-	2.20 (kg)	05	151035	268021	148006
	80 - 36	100.00 - 130.00	90.00	60.00	-	3.00 (kg)	05	151009	268022	148007
	80 - 36	125.00 - 155.00	90.00	60.00	-	3.10 (kg)	05	151010	268023	148007
	80 - 36	150.00 - 205.00	90.00	60.00	125.00	4.00 (kg)	05	151010	268023	148009

NOTE: Insert holders sold in quantities of 1, and inserts sold separately

Key on B10-D-1

B10-M: 12-13

B10-D: 23

B10-F

B10-H

B10: VI-VII

m = Metric (mm)

Inserts sold separately

IMPORTANT: Max spindle speed refers to maximum possible speed for an individual boring head and is not a recommended parameter. Refer to page B10-M: 12 for recommended application-specific parameters. Factory technical assistance is available for your specific applications through our Application Engineering department.
 email: engineering.eu@alliedmachine.com

Chamfering Tools

Diameter Range: 25 .00 mm - 32.00 mm

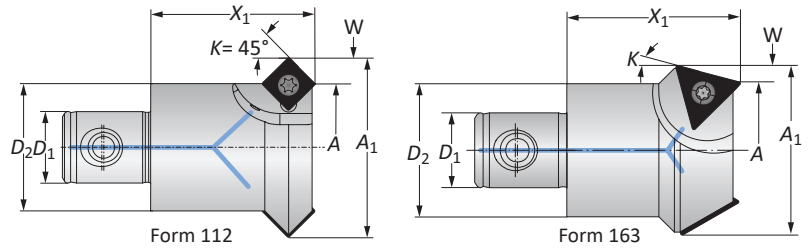

Connection	Approach Angle	Boring Range	Cutter Diameter	Chamfering Tool		Weight	Insert Form	Number of Inserts	Part No.
				X_1	W				
$D_2 D_1$	K	A	A_1	X_1	W				
25 - 14	15°	25.00	33.00	31.00	4.00	0.15 (kg)	163	2	201087
25 - 14	45°	20.00	33.00	31.00	6.50	0.15 (kg)	112	2	201082
32 - 18	15°	32.00	40.00	41.00	4.00	0.20 (kg)	163	2	201088
32 - 18	30°	25.00	41.00	41.00	8.00	0.20 (kg)	163	2	201089
32 - 18	45°	32.00	45.00	41.00	6.50	0.20 (kg)	112	3	201083

NOTE: K 45° for front and reverse side chamfering

NOTE: Inserts sold separately

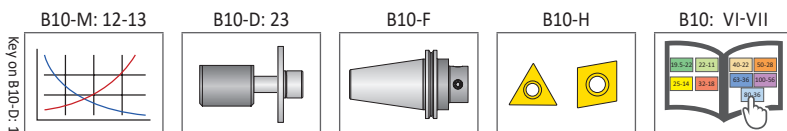

 = Metric (mm)

Inserts sold separately

IMPORTANT: Max spindle speed refers to maximum possible speed for an individual boring head and is not a recommended parameter. Refer to page B10-M: 12 for recommended application-specific parameters. Factory technical assistance is available for your specific applications through our Application Engineering department.
 email: engineering.eu@alliedmachine.com

Chamfering Tools

Metric | Diameter Range: 19.00 mm - 71.00 mm

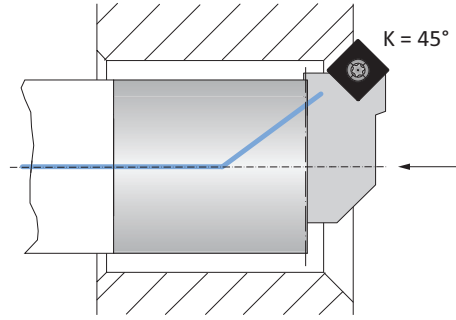
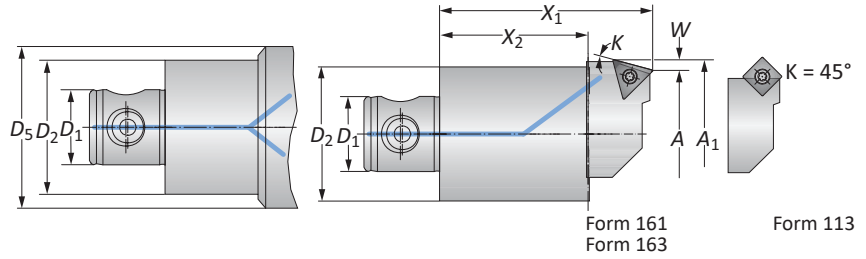

Connection	Approach Angle	Boring Range	Chamfering Range	Chamfering Tool				Weight (lbs)	Insert Form	Part No.	
				$D_2 D_1$	K	A	A_1			X_1	X_2
25 - 14	15°	24.00 - 32.00	29.00 - 37.00	60.00	42.00	-	2.50	0.20 (kg)	161	201057	148001
25 - 14	15°	31.00 - 39.00	36.00 - 44.00	60.00	42.00	30.00	2.50	0.20 (kg)	161	201058	148002
25 - 14	20°	22.00 - 30.00	29.00 - 37.00	60.00	42.00	-	3.50	0.20 (kg)	161	201017	148001
25 - 14	20°	29.00 - 37.00	36.00 - 44.00	60.00	42.00	30.00	3.50	0.20 (kg)	161	201018	148002
25 - 14	30°	20.00 - 28.00	29.00 - 37.00	60.00	42.00	-	4.50	0.20 (kg)	161	201067	148001
25 - 14	30°	27.00 - 35.00	36.00 - 44.00	60.00	42.00	30.00	4.50	0.20 (kg)	161	201068	148002
25 - 14	45°	19.00 - 27.00	33.00 - 41.00	58.00	42.00	-	5.00	0.20 (kg)	161	201003*	148001
25 - 14	45°	26.00 - 34.00	38.00 - 46.00	58.00	42.00	-	5.00	0.20 (kg)	112	201004	148001
25 - 14	45°	31.00 - 39.00	43.00 - 51.00	60.00	42.00	30.00	6.00	0.20 (kg)	112	201007	148002
32 - 18	15°	31.00 - 39.00	36.00 - 44.00	60.00	42.00	30.00	2.50	0.20 (kg)	161	201058	148017
32 - 18	20°	29.00 - 37.00	36.00 - 44.00	60.00	42.00	30.00	3.50	0.20 (kg)	161	201018	148017
32 - 18	30°	27.00 - 35.00	36.00 - 44.00	60.00	42.00	30.00	4.50	0.20 (kg)	161	201068	148017
32 - 18	45°	31.00 - 39.00	43.00 - 51.00	60.00	42.00	30.00	6.00	0.20 (kg)	112	201077	148017
32 - 18	15°	35.00 - 46.00	43.00 - 54.00	71.00	46.00	36.00	4.00	0.40 (kg)	163	201059	148003
32 - 18	20°	33.00 - 44.00	43.00 - 54.00	71.00	46.00	36.00	5.00	0.40 (kg)	163	201019	148003
32 - 18	30°	28.00 - 39.00	43.00 - 54.00	71.00	46.00	36.00	7.50	0.40 (kg)	163	201069	148003
32 - 18	45°	35.00 - 46.00	50.00 - 61.00	66.00	46.00	36.00	7.50	0.40 (kg)	113	201008	148003
40 - 22	15°	35.00 - 46.00	43.00 - 54.00	71.00	46.00	36.00	4.00	0.40 (kg)	163	201059	148018
40 - 22	20°	33.00 - 44.00	43.00 - 54.00	71.00	46.00	36.00	5.00	0.40 (kg)	163	201019	148018
40 - 22	30°	28.00 - 39.00	43.00 - 54.00	71.00	46.00	36.00	7.50	0.40 (kg)	163	201069	148018
40 - 22	45°	35.00 - 46.00	50.00 - 61.00	66.00	46.00	36.00	7.50	0.40 (kg)	113	201008	148018
40 - 22	15°	37.00 - 50.00	45.00 - 58.00	80.00	55.00	-	4.00	0.70 (kg)	163	201060	148004
40 - 22	20°	37.00 - 50.00	47.00 - 60.00	80.00	55.00	-	5.00	0.70 (kg)	163	201020	148004
40 - 22	30°	37.00 - 50.00	52.00 - 65.00	80.00	55.00	-	7.50	0.70 (kg)	163	201070	148004
40 - 22	45°	43.00 - 56.00	58.00 - 71.00	80.00	55.00	-	7.50	0.70 (kg)	113	201009	148004

*Insert holder cannot be used for reverse machining.
NOTE: K 45° for front and reverse side chamfering above \varnothing 31.00 mm
NOTE: Insert holders and inserts sold separately

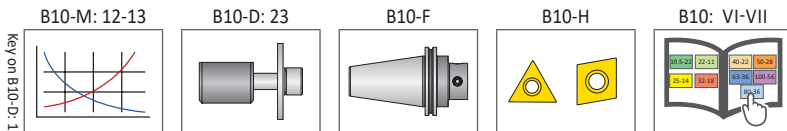

Ⓜ = Metric (mm)

Inserts sold separately

IMPORTANT: Max spindle speed refers to maximum possible speed for an individual boring head and is not a recommended parameter. Refer to page B10-M: 12 for recommended application-specific parameters. Factory technical assistance is available for your specific applications through our Application Engineering department.
 email: engineering.eu@alliedmachine.com

Chamfering Tools

Diameter Range: 50.00 mm - 216.00 mm

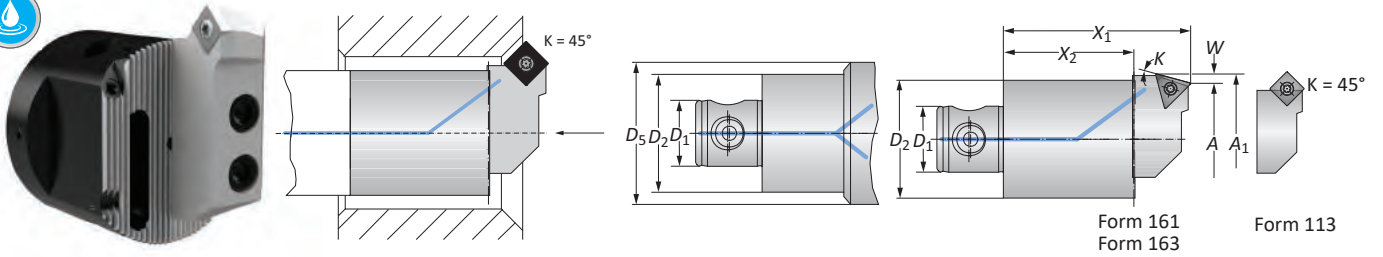

Connection	Approach Angle	Boring Range	Chamfering Range	Chamfering Tool				Weight	Insert Form	Part No.	
				$D_2 D_1$	K	A	A_1			X_1	X_2
50 - 28	15°	50.00 - 68.00	58.00 - 76.00	80.00	55.00	-	4.00	1.00 (kg)	163	201061	148005
50 - 28	20°	50.00 - 68.00	60.00 - 78.00	80.00	55.00	-	5.00	1.00 (kg)	163	201021	148005
50 - 28	30°	50.00 - 68.00	65.00 - 83.00	80.00	55.00	-	7.50	1.00 (kg)	163	201071	148005
50 - 28	45°	55.00 - 73.00	70.00 - 88.00	80.00	55.00	-	7.50	1.00 (kg)	113	201010	148005
63 - 36	15°	68.00 - 89.00	76.00 - 97.00	90.00	60.00	-	4.00	1.90 (kg)	163	201062	148006
63 - 36	20°	68.00 - 89.00	78.00 - 99.00	90.00	60.00	-	5.00	1.90 (kg)	163	201022	148006
63 - 36	30°	68.00 - 89.00	83.00 - 104.00	90.00	60.00	-	7.50	1.90 (kg)	163	201072	148006
63 - 36	45°	72.00 - 93.00	87.00 - 108.00	90.00	60.00	-	7.50	1.90 (kg)	113	201011	148006
80 - 36	15°	89.00 - 119.00	97.00 - 127.00	90.00	60.00	-	4.00	2.60 (kg)	163	201063	148007
80 - 36	15°	119.00 - 149.00	127.00 - 159.00	90.00	60.00	-	4.00	2.70 (kg)	163	201064	148007
80 - 36	15°	144.00 - 199.00	152.00 - 207.00	90.00	60.00	125.00	4.00	3.60 (kg)	163	201064	148009
80 - 36	20°	89.00 - 119.00	99.00 - 129.00	90.00	60.00	-	5.00	2.60 (kg)	163	201023	148007
80 - 36	20°	119.00 - 149.00	129.00 - 159.00	90.00	60.00	-	5.00	2.70 (kg)	163	201024	148007
80 - 36	20°	144.00 - 199.00	154.00 - 209.00	90.00	60.00	125.00	5.00	3.60 (kg)	163	201024	148009
80 - 36	30°	89.00 - 119.00	104.00 - 134.00	90.00	60.00	-	7.50	2.60 (kg)	163	201073	148007
80 - 36	30°	119.00 - 149.00	134.00 - 164.00	90.00	60.00	-	7.50	2.70 (kg)	163	201074	148007
80 - 36	30°	144.00 - 199.00	159.00 - 214.00	90.00	60.00	125.00	7.50	3.60 (kg)	163	201074	148009
80 - 36	45°	92.00 - 122.00	107.00 - 137.00	90.00	60.00	-	7.50	2.60 (kg)	113	201012	148007
80 - 36	45°	121.00 - 151.00	136.00 - 166.00	90.00	60.00	-	7.50	2.70 (kg)	113	201013	148007
80 - 36	45°	146.00 - 201.00	161.00 - 216.00	90.00	60.00	125.00	7.50	3.60 (kg)	113	201013	148009

NOTE: K 45° = front and reverse side chamfering
NOTE: Insert holders and inserts sold separately

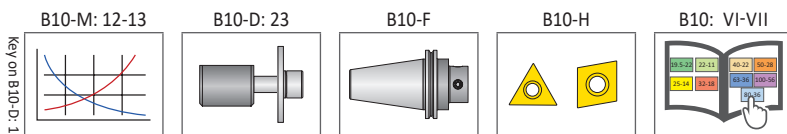

 = Metric (mm)
 Inserts sold separately

IMPORTANT: Max spindle speed refers to maximum possible speed for an individual boring head and is not a recommended parameter. Refer to page B10-M: 12 for recommended application-specific parameters. Factory technical assistance is available for your specific applications through our Application Engineering department.
 email: engineering.eu@alliedmachine.com

Grooving Tools for Circular Milling

Diameter Range: $\varnothing > 20.00$ mm

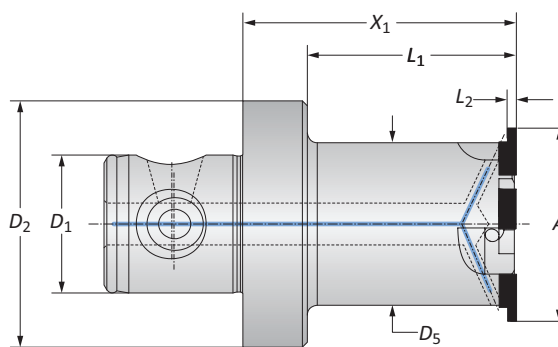
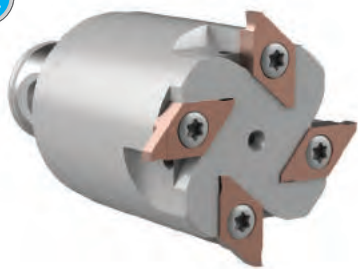

Connection	Cutter Diameter	Grooving Tool			Groove Width	Groove Depth	Number of Inserts	Weight	Insert Form	Part No.	
		$D_2 D_1$	A	X_1							L_1
m	50 - 28	20.00	55.00	40.00	17.00	max 2.37	max 1.50	2	0.40 (kg)	89	143051
	50 - 28	20.00	95.00	82.00	17.00	max 2.37	max 1.50	2	0.40 (kg)	89	143052
	50 - 28	39.00	55.00	42.00	33.00	max 3.37	max 2.50	4	0.60 (kg)	90	143053
	32 - 18	39.00	40.00	40.00	33.00	max 3.37	max 2.50	4	0.30 (kg)	90	143054
	50 - 28	49.00	55.00	40.00	43.00	max 3.37	max 2.50	5	0.70 (kg)	90	143055
	40 - 22	49.00	40.00	40.00	43.00	max 3.37	max 2.50	5	0.50 (kg)	90	143056
	50 - 28	63.00	40.00	40.00	53.00	max 5.87	max 4.70	6	0.70 (kg)	91	143057
	63 - 36	79.00	40.00	40.00	69.00	max 5.87	max 4.70	8	1.20 (kg)	91	143058

NOTE: Different lengths available upon request.
NOTE: Insert holders and inserts sold separately

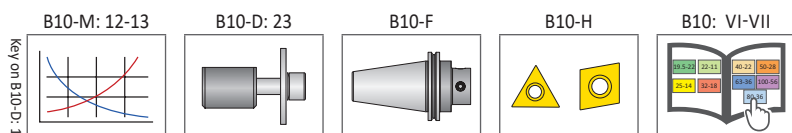

m = Metric (mm)

Inserts sold separately

IMPORTANT: Max spindle speed refers to maximum possible speed for an individual boring head and is not a recommended parameter. Refer to page B10-M: 12 for recommended application-specific parameters. Factory technical assistance is available for your specific applications through our Application Engineering department.
 email: engineering.eu@alliedmachine.com

Axial Grooving Tools

Diameter Range: 20.00 mm - 205.00 mm

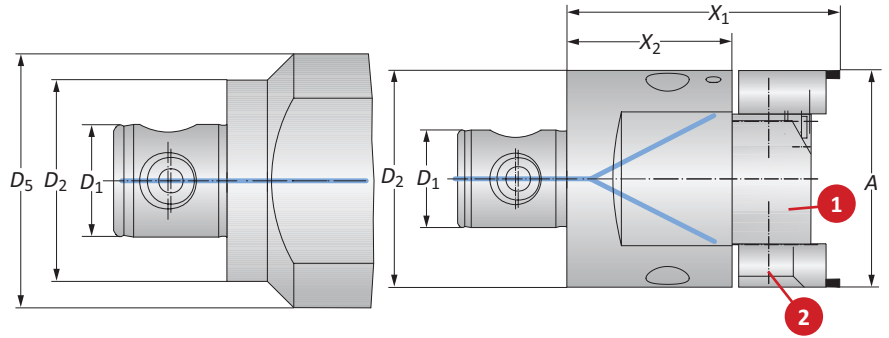

Connection	Boring Range	Grooving Tool				Weight	Part No.			
		$D_2 D_1$	A	X_1	X_2		D_5	1. Support Block	Insert Form	2. Insert Holder
M	50 - 28	20.00 - 58.00	83.00	55.00	63.00	1.30 (kg)	–	304	226030	148010
	80 - 36	57.00 - 84.00	100.00	60.00	–	2.60 (kg)	226011	304	226031	148007
	80 - 36	82.00 - 155.00	100.00	60.00	125.00	3.70 (kg)	226012	304	226031	148009
	80 - 36	153.00 - 205.00	100.00	60.00	125.00	3.70 (kg)	226013	304	226031	148009

NOTE: Groove width is 0.039" - 0.276" (1.00 mm - 7.00 mm). (With Twin Cutter and diameter offset up to 12.00 mm is possible.) | Groove depth is 0.039" - 0.236" (1.00 mm - 6.00 mm)

NOTE: Support block with machining diameters smaller than 4.842" (123.00 mm) can only be secured with one screw

NOTE: Insert holders, support blocks, and inserts sold separately

Examples of recessing replaceable inserts:

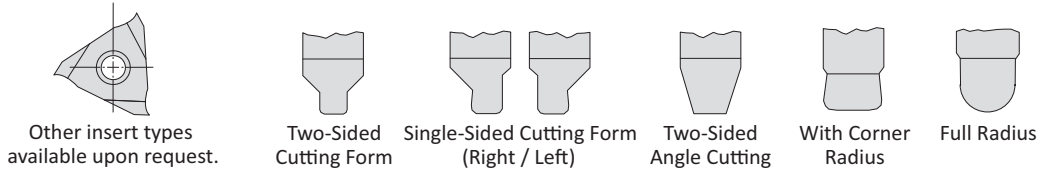

Other insert types available upon request.

Two-Sided Cutting Form

Single-Sided Cutting Form (Right / Left)

Two-Sided Angle Cutting

With Corner Radius

Full Radius

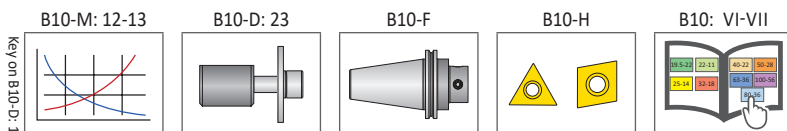

M = Metric (mm)

Inserts sold separately

IMPORTANT: Max spindle speed refers to maximum possible speed for an individual boring head and is not a recommended parameter. Refer to page B10-M: 12 for recommended application-specific parameters. Factory technical assistance is available for your specific applications through our Application Engineering department.
 email: engineering.eu@alliedmachine.com

Reverse Machining Tools

Diameter Range: 29.00 mm - 245.00 mm

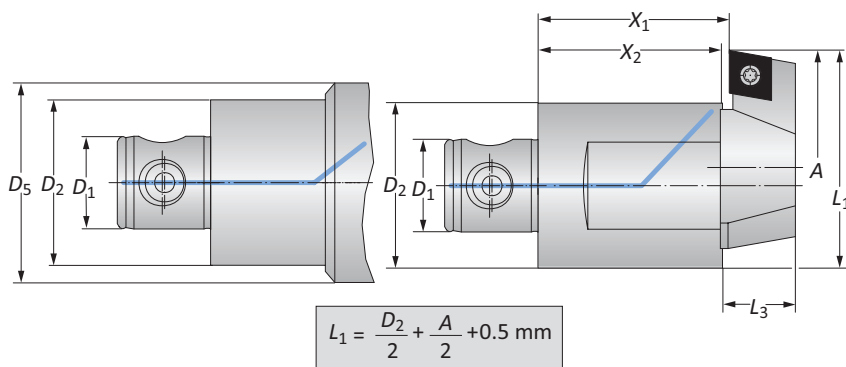

Connection	Boring Range	Reverse Machining				D ₅	Weight	Insert Form	Part No.	
		D ₂ D ₁	A	X ₁	X ₂				L ₃	Insert Holder
M	25 - 14	29.00 - 37.00	40.00	39.00	14.00	-	0.20 (kg)	103	251001	148011
	25 - 14	34.00 - 42.00	40.00	39.00	14.00	-	0.20 (kg)	103	251002	148011
	25 - 14	36.00 - 44.00	40.00	39.00	14.00	-	0.20 (kg)	103	251002	148012
	25 - 14	44.00 - 52.00	40.00	39.00	18.00	-	0.20 (kg)	104	251003	148012
	32 - 18	43.00 - 54.00	40.00	39.00	18.00	-	0.30 (kg)	104	251003	148013
	32 - 18	55.00 - 66.00	40.00	39.00	18.00	-	0.40 (kg)	104	251004	148013
	40 - 22	53.00 - 72.00	40.00	39.00	18.00	-	0.50 (kg)	104	251004	148014
	40 - 22	66.00 - 85.00	40.00	39.00	18.00	-	0.50 (kg)	104	251005	148014
	50 - 28	70.00 - 95.00	56.00	55.00	22.00	-	1.10 (kg)	104	251006	148015
	50 - 28	92.00 - 117.00	56.00	55.00	22.00	-	1.30 (kg)	104	251007	148015
G	63 - 36	92.00 - 122.00	56.00	55.00	22.00	-	1.70 (kg)	104	251007	148016
	80 - 36	120.00 - 150.00	62.00	60.00	26.00	-	2.70 (kg)	104	251008	148007
	80 - 36	166.00 - 196.00	62.00	60.00	26.00	-	2.90 (kg)	104	251009	148007
	80 - 36	145.00 - 200.00	62.00	60.00	26.00	125.00	3.60 (kg)	104	251008	148009
	80 - 36	190.00 - 245.00	62.00	60.00	26.00	125.00	3.70 (kg)	104	251009	148009

NOTE: Only use inserts with chip grooves all around

NOTE: Insert holders and inserts sold separately

Key on B10-D-1

B10-M: 12-13

B10-D: 23

B10-F

B10-H

B10: VI-VII

M = Metric (mm)

Inserts sold separately

IMPORTANT: Max spindle speed refers to maximum possible speed for an individual boring head and is not a recommended parameter. Refer to page B10-M: 12 for recommended application-specific parameters. Factory technical assistance is available for your specific applications through our Application Engineering department.
 email: engineering.eu@alliedmachine.com

VolCut Insert Holders

Diameter Range: 65.00 mm - 3255.00 mm

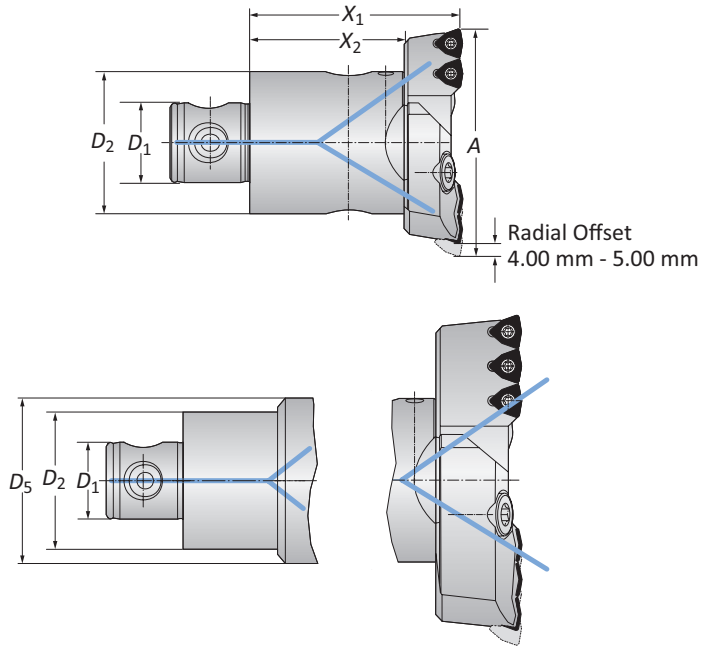

Serrated Bodies with VolCut Insert Holders



Connection	Boring Range		Serrated Body			Weight	Number of Inserts	Insert Form	Part No.		
	D ₂ D ₁	A	A _{min} **	X ₁	X ₂				D ₅	VolCut Insert Holder	Serrated Body
m	50 - 28	65.00 - 83.00	65.00 - 70.00	74.00	55.00	-	1.10 (kg)	2	464	151019	148005
	63 - 36	82.00 - 103.00	82.00 - 87.00	89.00	60.00	-	2.20 (kg)	3	464	151039	148006
	80 - 36	100.00 - 130.00	100.00 - 105.00	89.00	60.00	-	3.00 (kg)	3	464	151059	148007
	80 - 36	125.00 - 155.00	125.00 - 130.00	89.00	60.00	-	3.20 (kg)	3	464	151069	148007
	80 - 36	150.00 - 205.00	150.00 - 155.00	89.00	60.00	125.00	5.10 (kg)	3	464	151069	148009
⚠ D60	200.00 - 3255.00	-	-	-	-	-	-	3	464	149030	*

NOTE: Inserts, insert holders, and serrated body are sold separately.

*For large diameter serrated slides, please contact Application Eng. on enquiries.eu@alliedmachine.com and see section B10-G in the Wohlhaupter® MultiBore® System Tools catalogue.

**For smaller diameters, both cartridges must be set to the same diameter. Only the outside insert on each cartridge can be engaged in the material.

IC Inserts

Carbide Grade	Geometry	Part No.	WSP-Screw
		 AM300®	
P35 (C5)	Standard	OP-05T308-P	IS-10-1
K35 (C1)	Standard	OP-05T308-1P	IS-10-1
K20 (C2)	Standard	OP-05T308-2P	IS-10-1
P35 (C5)	High Rake	OP-05T308-PHR	IS-10-1

NOTE: See section A70 in the Allied Master Product Catalogue for recommended cutting data, cutting materials, and geometries.

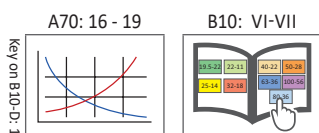

m = Metric (mm)

⚠ WARNING For large diameter boring with VolCut insert holders please:
 - Contact our Application Engineering department before purchasing (email: engineering.eu@alliedmachine.com)
 - Refer to section B10-G in the Wohlhaupter® MultiBore® System Tools catalogue.

VolCut Technical Information

Setup Instructions | Minimum Pilot Calculation

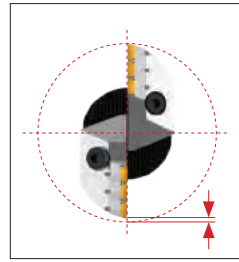

Step 1:
Loosen the mounting screws on both cartridges.

Step 2:
Set one cartridge to the finish diameter by tightening the adjustment screw against the adjustment pin.

Step 3:
Tighten the mounting screws on the cartridge to 15-19 Nm.

Step 4:
Set the opposing cartridge with 4 mm - 5 mm radial offset inward by tightening the adjustment screw against the adjustment pin (optimum situation for each insert to remove equal material).

Step 5:
Tighten the mounting screws on the cartridge to 15-19 Nm.

Note: Drilling systems with OP inserts are used as single cutters. The replaceable inserts are mounted offset in diameter. Please review the assembly instructions.

Minimum Pilot Calculation

Calculation: Finish Diameter - Opening Range = Minimum Pilot Hole Diameter

Insert Holder	Diameter Range	Opening Range
151019	65.00 mm - 70.00 mm	15.24 mm
	70.00 mm - 83.00 mm	47.75 mm
151039	82.00 mm - 87.00 mm	15.24 mm
	87.00 mm - 103.00 mm	68.07 mm
151059	100.00 mm - 105.00 mm	15.24 mm
	105.00 mm - 130.00 mm	68.07 mm
151069	125.00 mm - 130.00 mm	15.24 mm
	130.00 mm - 205.00 mm	68.07 mm
149030	200.00 mm - 3255.00 mm	68.07 mm

Example: To open an existing hole to 114.30 mm diameter, a 151059 insert holder would be used with a 148007 serrated tool body, and the minimum pilot diameter would be 114.30 mm - 68.07 mm = 46.23 mm.

Accessories

Clamping Elements | Axial Grooving Accessories

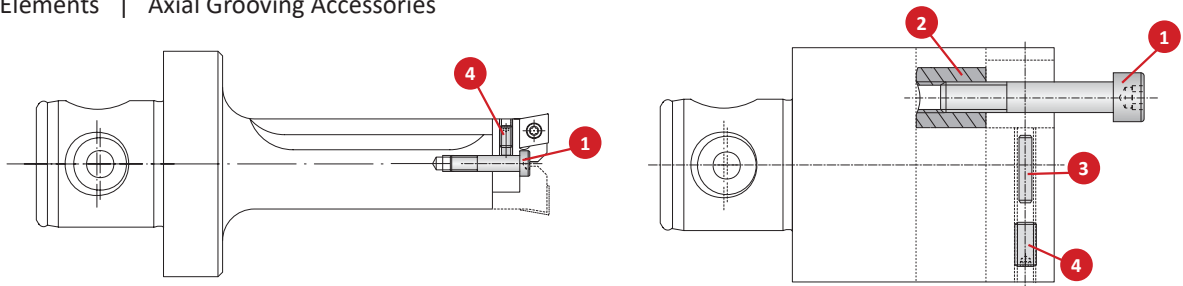

Clamping Elements

Connection	Serrated Tool Body	Part No.					
		1. Cap Screw	Service Key	2. Clamping Nut	3. Adjustment Pin	4. Thread Pin	Service Key
25 - 14	148001	140108	s4 / B	140114	-	115280	s2.5 / A
25 - 14	148002	148110	s5 / B	115667	-	126157	s2.5 / A
25 - 14	148011	148110	s5 / B	148113	-	117148	s2.5 / A
25 - 14	148012	148110	s5 / B	115666	-	117148	s2.5 / A
32 - 18	148003	140110	s5 / B	115667	-	126157	s2.5 / A
32 - 18	148013	148110	s5 / B	148114	-	115192	s2.5 / A
32 - 18	148017	148110	s5 / B	115667	-	126157	s2.5 / A
40 - 22	148004	140110	s5 / B	140116	-	115407	s2.5 / A
40 - 22	148014	148110	s5 / B	148114	-	126157	s2.5 / A
40 - 22	148018	140110	s5 / B	115667	-	126157	s2.5 / A
50 - 28	148005	140111	s6 / B	140117	-	140121	s2.5 / A
50 - 28	148010	140111	s6 / B	140117	-	140121	s2.5 / A
50 - 28	148015	140112	s6 / B	140117	-	215111	s2.5 / A
50 - 28	235001	415111	T25 / B	-	-	215346	s1.5 / A
50 - 28	235002	415112	T25 / B	-	-	215346	s1.5 / A
50 - 28	235003	415113	T25 / B	-	-	215346	s1.5 / A
50 - 28	148021	140108	s4 / B	140114	-	115280	s2.5 / A
50 - 28	148022	140110	s5 / B	115667	-	126157	s2.5 / A
50 - 28	148023	140110	s5 / B	115667	-	126157	s2.5 / A
50 - 28	148024	140110	s5 / B	140116	-	115407	s2.5 / A
63 - 36	148006	140112	s6 / B	140118	-	140121	s2.5 / A
63 - 36	148016	140112	s6 / B	140117	-	116550	s2.5 / A
63 - 36	235011	415111	T25 / B	-	-	215346	s1.5 / A
63 - 36	235012	415112	T25 / B	-	-	215346	s1.5 / A
63 - 36	235013	415113	T25 / B	-	-	215346	s1.5 / A
80 - 36	148007	115730	s6 / B	140119	-	116550	s2.5 / A
80 - 36	148009	115730	s6 / B	140119	140120	115519	s2.5 / A
∅ 18	235021	415111	T25 / B	-	-	215346	s1.5 / A
∅ 20	235022	415112	T25 / B	-	-	215346	s1.5 / A
∅ 23	235023	415113	T25 / B	-	-	215346	s1.5 / A

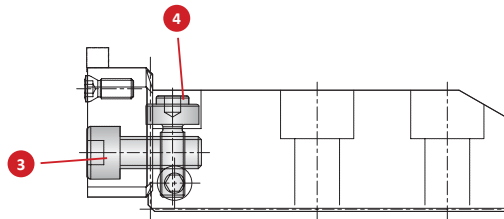

Axial Grooving Accessories

Support Base	3. Cap Screw		4. Axial Adjustment Screw	
	Part No.	Service Key	Part No.	Service Key
226011	023182	s6 / B	215374	s4 / B
226012	023182	s6 / B	215374	s4 / B
226013	023182	s6 / B	215374	s4 / B

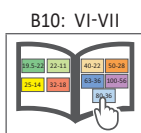
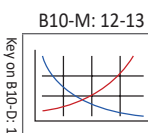

 = Metric (mm)

SECTION

B10-E

Intermediate Modules

Wohlhaupter® Intermediate Modules

NOVI^{TECH}® | Reducers | Extensions



Increase Tool Stability with Intermediate Modules

- Allow for expanded use of existing components
- Add flexibility to setups
- Reduce need for specials and their associated cost and lead time
- Each component individually balanced

Your safety and the safety of others is very important. This catalogue contains important safety messages. Always read and follow all safety precautions.



This triangle is a safety hazard symbol. It alerts you to potential safety hazards that can cause tool failure and serious injury.

When you see this symbol in the catalogue, look for a related safety message that may be near this triangle or referred to in the nearby text.

There are safety signal words also used in the catalogue. Safety messages follow these words.

WARNING

WARNING (shown above) means that failure to follow the precautions in this message could result in tool failure and serious injury.

NOTICE means that failure to follow the precautions in this message could result in damage to the tool or machine but not result in personal injury.

NOTE and **IMPORTANT** are also used. These are important that you read and follow but are not safety-related.

Visit www.alliedmachine.com for the most up-to-date information and procedures.

Applicable Industries



Aerospace



Agriculture



Automotive



Firearms



General
Machining



Oil & Gas



Renewable
Energy

Reference Icons

The following icons will appear throughout the catalogue to help you navigate between products.

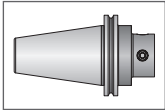

Shanks

A variety of shanks for different machines

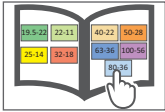

MVS Connection Color Guide

Detailed instructions and information regarding the MVS connection(s)

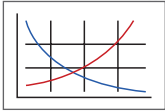

Recommended Cutting Data

Speed and feed recommendations for optimum and safe boring



Through Coolant Option

Indicates that the product is through coolant

Intermediate Modules Table of Contents

Introduction

Product Overview 2 - 3

NOVI^{TECH}® Vibration Damping Modules 4 - 5

248 Adapters 6 - 7

Reducers 8 - 11

Extensions 12 - 13

Intermediate Modules Product Overview

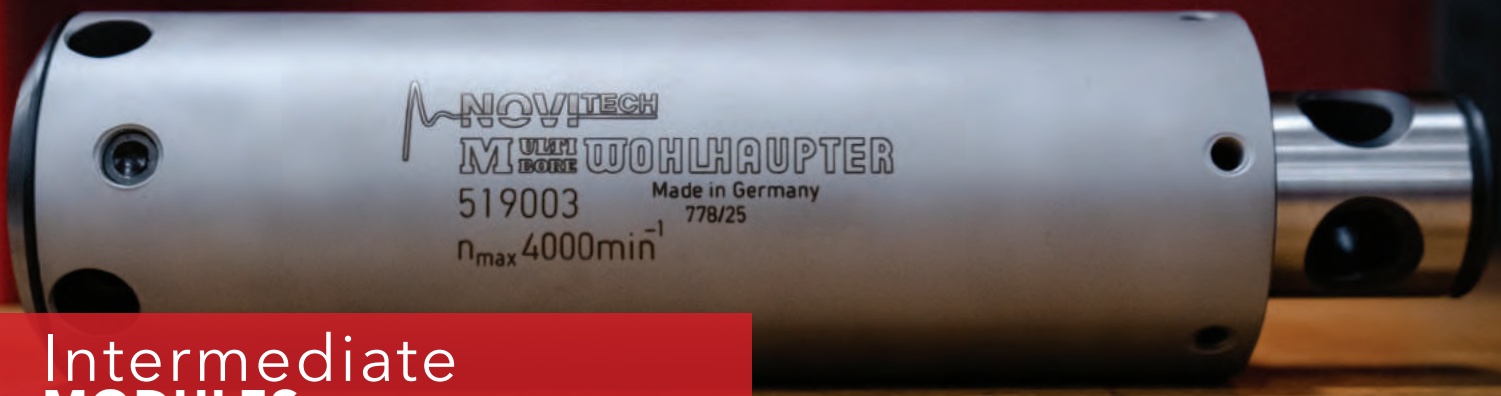

Intermediate MODULES

Reducers

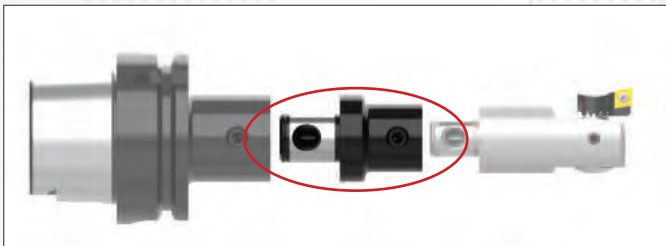

Features:

- ▶ Improves rigidity by stepping-down to smaller MVS connection sizes
- ▶ Connects quickly and easily with the MVS connection
- ▶ Accommodates smaller diameter applications

Extensions

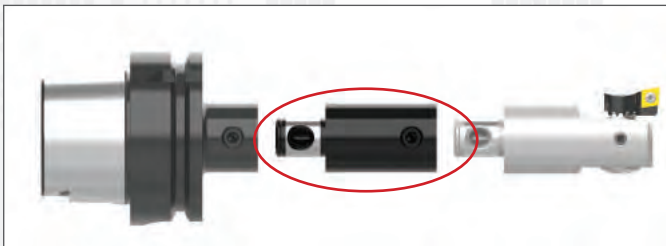

Features:

- ▶ Used to increase bore depth
- ▶ Connects quickly and easily with the MVS connection
- ▶ Aluminium components available to reduce stress on the spindle

WOHLHAUPTER® FINE BORING HEAD with NOVI^{TECH}®

Are you looking for more from your tooling?

After facing problems with chatter and chipping inserts, our customer, who machines fueling machine head rotors from ASTM A276 - 304L in the nuclear power industry, sought a better solution to their machining process.

The customer turned to Allied for help finding a new solution. Once the causes of insert failure and chatter were identified, our experienced team was able to create the best assembly suitable for the application. Using **Wohlhaupter's analogue balanced fine boring head** paired with the **NOVI^{TECH} vibration dampening module**, they were able to eliminate the issues our customers were facing.

With the previous tooling, the customer achieved only 12 minutes of tool life, but with Allied's Wohlhaupter assembly, they achieved more than four times the life for 65 minutes!

Allied's Wohlhaupter assembly improved the machining process by making it more consistent and saved the customer money by reducing the cost per hole. If you are looking to save time and money, **give us a call, and we will help you find the right solution.**

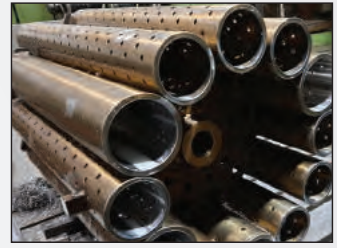

		Measure	Competitor Boring Head	Wohlhaupter Fine Boring Head with NOVI ^{TECH}
Product:	Wohlhaupter analogue balanced fine boring head with NOVI ^{TECH}	RPM	106	372
Objectives:	(1) Decrease cycle time (2) Improve process	Speed Rate	40 M/min	140 M/min
Industry:	Renewable energy/energy	Feed Rate	0.076 mm/rev	0.16 mm/rev
Part:	Nuclear fueling machine head rotor	Penetration Rate	9 mm/min	60 mm/min
Material:	ASTM A276-304L	Cycle Time	2 hr 10 min	17 min
Hole Ø:	120 mm	Tool Life	12 min	65 min
Hole Depth:	1040 mm	Wohlhaupter offered 93.32% cost per hole savings over the competitor tooling.		

- ▶ Analogue balanced fine boring head
- ▶ Boring insert
Item No. 297994WHC111
- ▶ NOVI^{TECH} vibration dampening intermediate module
Item No. 519004

*86.92%
cycle time reduction*



The Wohlhaupter boring head with the NOVI^{TECH} vibration dampening module provided:

- ✓ Increased penetration rate
- ✓ Decreased cycle time
- ✓ Increased tool life
- ✓ Decreased cost per hole



THE DEEP HOLE 10xD BORING SOLUTION YOU'VE BEEN LOOKING FOR

OUR SOLUTION

- ▶ Machine up to **10xD**
- ▶ Connect quickly and easily with the **MVS connection**
- ▶ Utilise existing **Wohlhaupter® components**
- ▶ **Increase** your productivity, surface quality, and process reliability
- ▶ **Increase** your tool and spindle life

YOUR ADVANTAGE

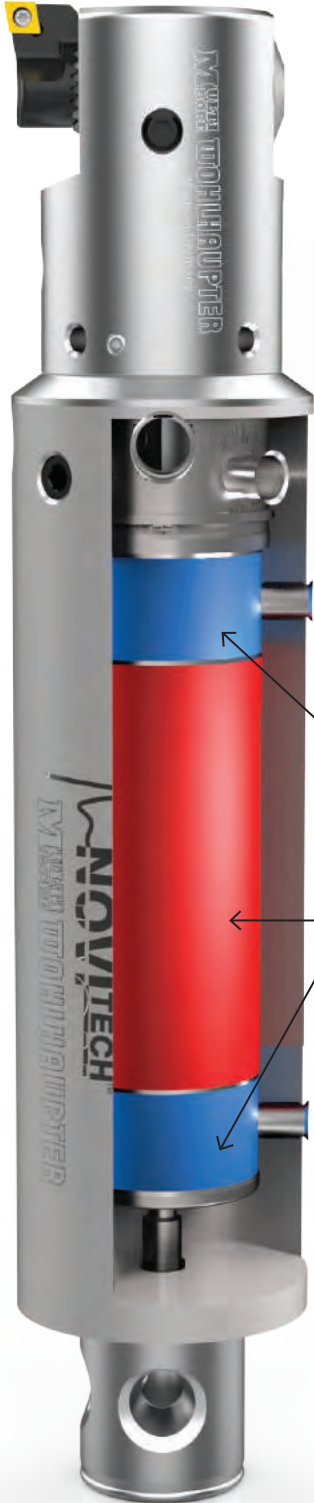

Dampening module with viscoelastic bearing

Absorber mass

THE SURFACE QUALITY TELLS IT ALL

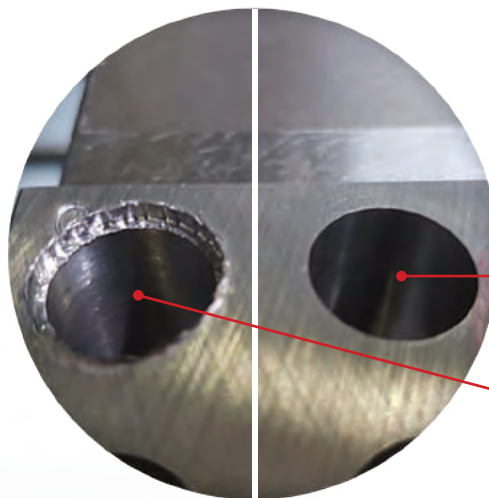

When our customer was machining alloy steel to 9xD, the NOVITECH provided reliable machining, which achieved high surface quality (Ra = 1 µm).

Wohlhaupter NOVITECH with VarioBore precision boring head

Standard tool construction with steel extension

NOVI^{TECH}® Vibration Damping Intermediate Modules

Machining Diameter: 50.00 mm - 205.00 mm

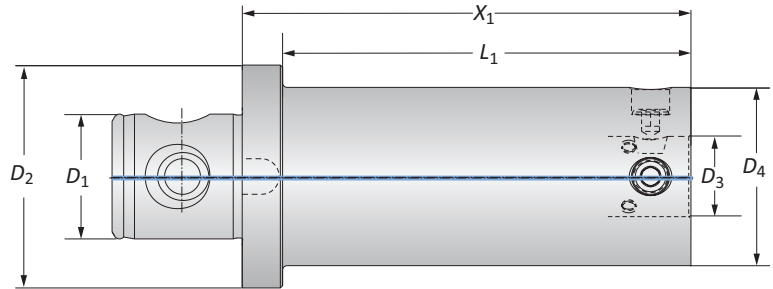
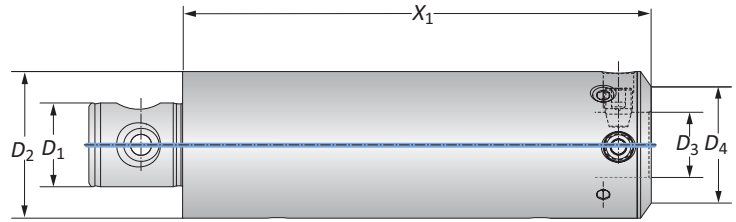

	MVS Connection		NOVI ^{TECH}		Weight	Part No.
	D ₂ D ₁	D ₄ D ₃	X ₁	L ₁		
Ⓜ	50 - 28*	40 - 22	200.00	-	2.80 (kg)	519002
	63 - 36	50 - 28	200.00	-	5.70 (kg)	519003
	80 - 36	63 - 36	200.00	-	7.50 (kg)	519004
	80 - 36	80 - 36	200.00	-	7.50 (kg)	519005
	100 - 56	80 - 36	200.00	182.00	9.90 (kg)	519006

*D₂ = 49.50 mm

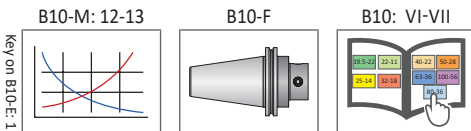

Ⓜ = Metric (mm)

IMPORTANT: Max spindle speed refers to maximum possible speed for an individual boring head and is not a recommended parameter. Refer to page B10-M: 12 for recommended application-specific parameters. Factory technical assistance is available for your specific applications through our Application Engineering department. [email: engineering.eu@alliedmachine.com](mailto:engineering.eu@alliedmachine.com)

⚠ WARNING Exceeding weight capacity for machine tool spindle and tool changer can cause machine damage and/or serious injury. To prevent:
 -Consult machine tool builder for machine's weight limitations.
 -Refer to example on page B10-M: 11 for calculating tool assembly weight
 Factory technical assistance is also available for specific applications through our Application Engineering department. [email: engineering.eu@alliedmachine.com](mailto:engineering.eu@alliedmachine.com)

⚠ WARNING Tool failure can cause serious injury. To prevent:
 -Do not exceed recommended 10xD length-to-diameter ratio or exceed 4 total components (including shank)
 -When using Alu-Line® components, do not exceed recommended 5xD length-to-diameter ratio
 -When using tool steel components, do not exceed recommended 6xD length-to-diameter ratio
 -When using heavy metal components, do not exceed recommended 8xD length-to-diameter ratio
 -When using a carbide shank, do not exceed recommended 9xD length-to-diameter ratio
 -When using a NOVITECH® module, do not exceed recommended 10xD length-to-diameter ratio
 -Refer to examples on pages B10-M: 8-10 for calculating length-to-diameter ratio
 Factory technical assistance is available for your specific applications through our Application Engineering department. [email: engineering.eu@alliedmachine.com](mailto:engineering.eu@alliedmachine.com)

248 Adapters

Adapters | Balanced Adapters

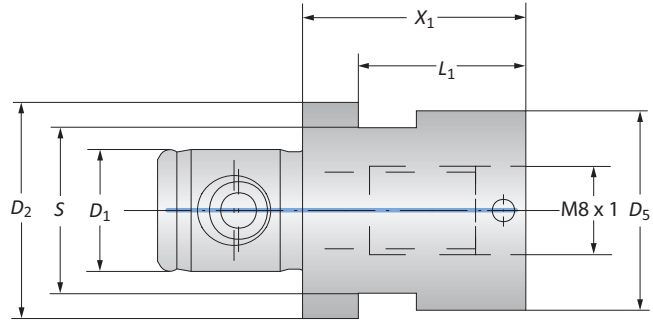

Adapters

MVS Connection	Boring Connection	Adapter				Weight	Service Key	Part No.
		D_2 D_1	X_1	L_1	S			
m 19.5 - 11	M8 x 1	20.00	15.00	15/P	18.00	0.05 (kg)	15 S / P	219168
m 23 - 11	M8 x 1	20.00	-	19/P	23.00	0.07 (kg)	19 S / P	219169

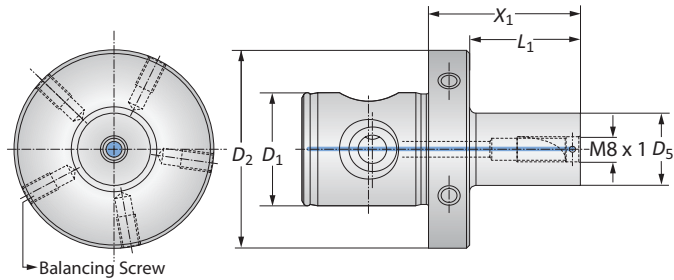

Balanced Adapters

MVS Connection	Boring Connection	Adapter			Weight	Balancing Screw	Part No.
		D_2 D_1	X_1	L_1			
m 50 - 28	M8 x 1	32.00	19.00	15.00	0.35 (kg)	M6 x 1 x 10	219185
m 50 - 28	M8 x 1	48.00	35.00	18.00	0.40 (kg)	M6 x 1 x 10	219176
m 50 - 28	M8 x 1	48.00	35.00	23.00	0.45 (kg)	M6 x 1 x 10	219177

NOTE: Balance refers to a specific residual imbalance of ≤ 10 g mm/kg

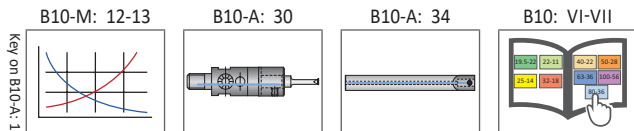

m = Metric (mm)

IMPORTANT: Max spindle speed refers to maximum possible speed for an individual boring head and is not a recommended parameter. Refer to page B10-M: 12 for recommended application-specific parameters. Factory technical assistance is available for your specific applications through our Application Engineering department. [email: engineering.eu@alliedmachine.com](mailto:engineering.eu@alliedmachine.com)

! WARNING Exceeding weight capacity for machine tool spindle and tool changer can cause machine damage and/or serious injury. To prevent:
 -Consult machine tool builder for machine's weight limitations.
 -Refer to example on page B10-M: 11 for calculating tool assembly weight
 Factory technical assistance is also available for specific applications through our Application Engineering department. [email: engineering.eu@alliedmachine.com](mailto:engineering.eu@alliedmachine.com)

! WARNING Tool failure can cause serious injury. To prevent:
 -Do not exceed recommended 10xD length-to-diameter ratio or exceed 4 total components (including shank)
 -When using Alu-Line® components, do not exceed recommended 5xD length-to-diameter ratio
 -When using tool steel components, do not exceed recommended 6xD length-to-diameter ratio
 -When using heavy metal components, do not exceed recommended 8xD length-to-diameter ratio
 -When using a carbide shank, do not exceed recommended 9xD length-to-diameter ratio
 -When using a NOVITECH® module, do not exceed recommended 10xD length-to-diameter ratio
 -Refer to examples on pages B10-M: 8-10 for calculating length-to-diameter ratio
 Factory technical assistance is available for your specific applications through our Application Engineering department. [email: engineering.eu@alliedmachine.com](mailto:engineering.eu@alliedmachine.com)

248 Adapters

Vibration Reducing Heavy Metal Adapters

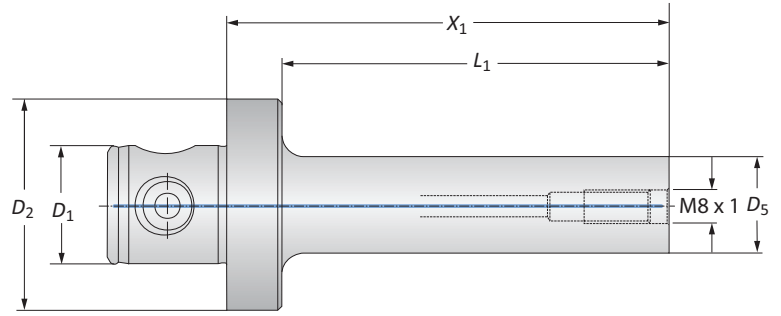

MVS Connection	Adapter						
	$D_2 D_1$	Boring Connection	X_1	L_1	D_5	Weight	Part No.
	50 - 28	M8 x 1	68.00	55.00	15.00	0.80 (kg)	248147
	50 - 28	M8 x 1	84.00	71.00	19.00	1.00 (kg)	248148
	50 - 28	M8 x 1	104.00	91.00	23.00	1.30 (kg)	248149

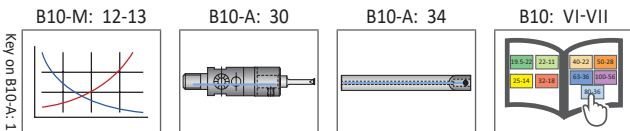

 = Metric (mm)

IMPORTANT: Max spindle speed refers to maximum possible speed for an individual boring head and is not a recommended parameter. Refer to page B10-M: 12 for recommended application-specific parameters. Factory technical assistance is available for your specific applications through our Application Engineering department. [email: engineering.eu@alliedmachine.com](mailto:engineering.eu@alliedmachine.com)

⚠ WARNING Exceeding weight capacity for machine tool spindle and tool changer can cause machine damage and/or serious injury. To prevent:
 -Consult machine tool builder for machine's weight limitations.
 -Refer to example on page B10-M: 11 for calculating tool assembly weight
 Factory technical assistance is also available for specific applications through our Application Engineering department. [email: engineering.eu@alliedmachine.com](mailto:engineering.eu@alliedmachine.com)

⚠ WARNING Tool failure can cause serious injury. To prevent:
 -Do not exceed recommended 10xD length-to-diameter ratio or exceed 4 total components (including shank)
 -When using Alu-Line® components, do not exceed recommended 5xD length-to-diameter ratio
 -When using tool steel components, do not exceed recommended 6xD length-to-diameter ratio
 -When using heavy metal components, do not exceed recommended 8xD length-to-diameter ratio
 -When using a carbide shank, do not exceed recommended 9xD length-to-diameter ratio
 -When using a NOVITECH® module, do not exceed recommended 10xD length-to-diameter ratio
 -Refer to examples on pages B10-M: 8-10 for calculating length-to-diameter ratio
 Factory technical assistance is available for your specific applications through our Application Engineering department. [email: engineering.eu@alliedmachine.com](mailto:engineering.eu@alliedmachine.com)

Reducers

Balanced

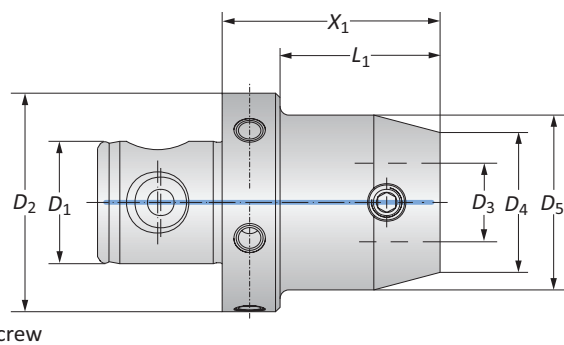
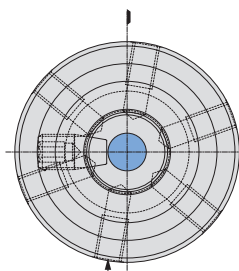
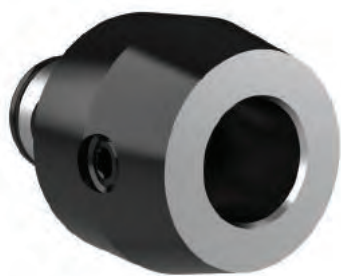

Balancing Screw

MVS Connection		Reducer				Weight	Balancing Screw	Part No.
D ₂ D ₁	D ₄ D ₃	X ₁	L ₁	D ₅				
25 - 14	19.5 - 11	30.00	21.00	-	0.10 (kg)	-	219034	
25 - 14	22 - 11	30.00	21.00	-	0.20 (kg)	-	219035	
32 - 18	22 - 11	12.00	0.50	-	0.10 (kg)	-	219036	
32 - 18	25 - 14	30.00	21.00	-	0.10 (kg)	-	219037	
40 - 22	22 - 11	12.00	0.50	-	0.20 (kg)	-	219038	
40 - 22	25 - 14	30.00	21.00	-	0.20 (kg)	-	219039	
40 - 22	32 - 18	30.00	-	40.00	0.50 (kg)	-	219040	
50 - 28	19.5 - 11	54.00	41.00	-	0.40 (kg)	M6 x 1 x 10	219051	
50 - 28	22 - 11	14.00	0.50	-	0.30 (kg)	M6 x 1 x 10	219041	
50 - 28	22 - 11	54.00	41.00	-	0.40 (kg)	M6 x 1 x 10	219052	
50 - 28	25 - 14	14.00	0.50	-	0.30 (kg)	M6 x 1 x 7	119094	
50 - 28	25 - 14	59.00	46.00	-	0.40 (kg)	M6 x 1 x 10	119054	
50 - 28	25 - 14	59.00	46.00	32.00	0.50 (kg)	M6 x 1 x 10	119055	
50 - 28	25 - 14	119.00	106.00	32.00	0.90 (kg)	M6 x 1 x 10	119010	
50 - 28	25 - 14	119.00	106.00	36.00	1.00 (kg)	M6 x 1 x 10	219030*	
50 - 28	32 - 18	49.00	36.00	35.00	0.90 (kg)	M6 x 1 x 10	219085	
50 - 28	32 - 18	109.00	96.00	35.00	1.00 (kg)	M6 x 1 x 10	219086	
50 - 28	32 - 18	109.00	96.00	40.00	1.10 (kg)	M6 x 1 x 10	119012	
50 - 28	32 - 18	109.00	96.00	46.00	1.30 (kg)	M6 x 1 x 10	219032*	
50 - 28	40 - 22	40.00	27.00	-	0.50 (kg)	M6 x 1 x 10	219087	
50 - 28	40 - 22	100.00	87.00	47.00	1.30 (kg)	M6 x 1 x 10	219088	
50 - 28	63 - 36	50.00	-	-	1.00 (kg)	M6 x 1 x 10	119059	

*Reinforced reducer

NOTE: Balance refers to a specific residual imbalance of ≤ 10 g mm/kg

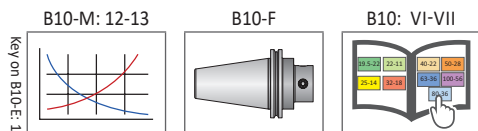

Ⓜ = Metric (mm)

IMPORTANT: Max spindle speed refers to maximum possible speed for an individual boring head and is not a recommended parameter. Refer to page B10-M: 12 for recommended application-specific parameters. Factory technical assistance is available for your specific applications through our Application Engineering department. [email: engineering.eu@alliedmachine.com](mailto:engineering.eu@alliedmachine.com)

⚠ WARNING Exceeding weight capacity for machine tool spindle and tool changer can cause machine damage and/or serious injury. To prevent:
 -Consult machine tool builder for machine's weight limitations.
 -Refer to example on page B10-M: 11 for calculating tool assembly weight
 Factory technical assistance is also available for specific applications through our Application Engineering department. [email: engineering.eu@alliedmachine.com](mailto:engineering.eu@alliedmachine.com)

⚠ WARNING Tool failure can cause serious injury. To prevent:
 -Do not exceed recommended 10xD length-to-diameter ratio or exceed 4 total components (including shank)
 -When using Alu-Line® components, do not exceed recommended 5xD length-to-diameter ratio
 -When using tool steel components, do not exceed recommended 6xD length-to-diameter ratio
 -When using heavy metal components, do not exceed recommended 8xD length-to-diameter ratio
 -When using a carbide shank, do not exceed recommended 9xD length-to-diameter ratio
 -When using a NOVITECH® module, do not exceed recommended 10xD length-to-diameter ratio
 -Refer to examples on pages B10-M: 8-10 for calculating length-to-diameter ratio
 Factory technical assistance is available for your specific applications through our Application Engineering department. [email: engineering.eu@alliedmachine.com](mailto:engineering.eu@alliedmachine.com)

Reducers

Balanced

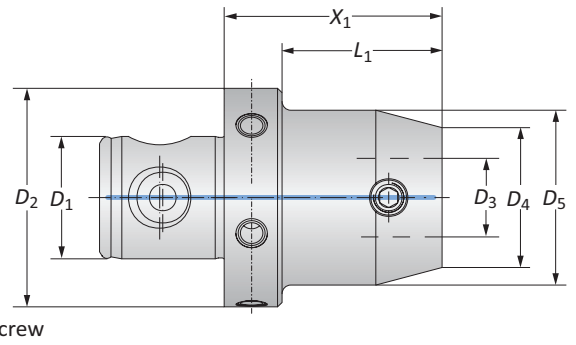
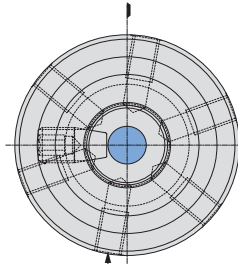

MVS Connection		Reducer			Weight	Balancing Screw	Part No.
D ₂ D ₁	D ₄ D ₃	X ₁	L ₁	D ₅			
63 - 36	19.5 - 11	54.00	41.00	-	0.60 (kg)	M6 x 1 x 10	219053
63 - 36	22 - 11	14.00	0.50	-	0.60 (kg)	M6 x 1 x 10	219042
63 - 36	22 - 11	54.00	41.00	-	0.70 (kg)	M6 x 1 x 10	219054
63 - 36	25 - 14	14.00	0.50	-	0.60 (kg)	M6 x 1 x 10	119095
63 - 36	25 - 14	59.00	46.00	-	0.70 (kg)	M6 x 1 x 10	119060
63 - 36	25 - 14	59.00	46.00	32.00	0.80 (kg)	M6 x 1 x 10	119061
63 - 36	25 - 14	119.00	106.00	32.00	1.10 (kg)	M6 x 1 x 15	119019
63 - 36	25 - 14	119.00	106.00	36.00	1.30 (kg)	M6 x 1 x 10	219031*
63 - 36	32 - 18	49.00	36.00	35.00	0.70 (kg)	M6 x 1 x 10	219089
63 - 36	32 - 18	109.00	96.00	35.00	1.20 (kg)	M6 x 1 x 10	219090
63 - 36	32 - 18	109.00	96.00	40.00	1.40 (kg)	M6 x 1 x 10	119021
63 - 36	32 - 18	109.00	96.00	46.00	1.60 (kg)	M6 x 1 x 10	219033*
63 - 36	40 - 22	40.00	27.00	-	0.80 (kg)	M6 x 1 x 10	219091
63 - 36	40 - 22	100.00	87.00	47.00	1.60 (kg)	M6 x 1 x 15	219092
63 - 36	40 - 22	150.00	137.00	50.00	2.40 (kg)	M6 x 1 x 15	119067
63 - 36	50 - 28	40.00	-	63.00	1.00 (kg)	M6 x 1 x 10	119064
63 - 36	50 - 28	40.00	27.00	-	0.80 (kg)	M6 x 1 x 10	119096**
63 - 36	50 - 28	100.00	-	63.00	2.40 (kg)	M6 x 1 x 15	119025
63 - 36	50 - 28	100.00	87.00	-	1.70 (kg)	M6 x 1 x 10	119097**
80 - 36	63 - 36	50.00	-	80.00	1.60 (kg)	M6 x 1 x 15	119098
100 - 56	80 - 36	70.00	52.00	-	3.60 (kg)	M8 x 1.25 x 20	219066

* Reinforced reducer

**For milling applications

NOTE: Balance refers to a specific residual imbalance of ≤ 10 g mm/kg

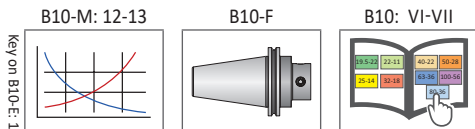

 = Metric (mm)

IMPORTANT: Max spindle speed refers to maximum possible speed for an individual boring head and is not a recommended parameter. Refer to page B10-M: 12 for recommended application-specific parameters. Factory technical assistance is available for your specific applications through our Application Engineering department. [email: engineering.eu@alliedmachine.com](mailto:engineering.eu@alliedmachine.com)

WARNING Exceeding weight capacity for machine tool spindle and tool changer can cause machine damage and/or serious injury. To prevent:
 -Consult machine tool builder for machine's weight limitations.
 -Refer to example on page B10-M: 11 for calculating tool assembly weight
 Factory technical assistance is also available for specific applications through our Application Engineering department. [email: engineering.eu@alliedmachine.com](mailto:engineering.eu@alliedmachine.com)

WARNING Tool failure can cause serious injury. To prevent:
 -Do not exceed recommended 10xD length-to-diameter ratio or exceed 4 total components (including shank)
 -When using Alu-Line® components, do not exceed recommended 5xD length-to-diameter ratio
 -When using tool steel components, do not exceed recommended 6xD length-to-diameter ratio
 -When using heavy metal components, do not exceed recommended 8xD length-to-diameter ratio
 -When using a carbide shank, do not exceed recommended 9xD length-to-diameter ratio
 -When using a NOVITECH® module, do not exceed recommended 10xD length-to-diameter ratio
 -Refer to examples on pages B10-M: 8-10 for calculating length-to-diameter ratio
 Factory technical assistance is available for your specific applications through our Application Engineering department. [email: engineering.eu@alliedmachine.com](mailto:engineering.eu@alliedmachine.com)

Reducer

Balanced Alu-Line

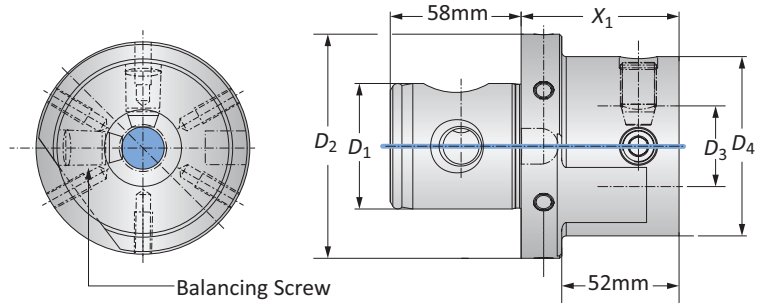

MVS Connection	Reducer		Weight	Balancing Screw	Part No.	
	$D_2 D_1$	$D_4 D_3$				X_1
m 100 - 56	80 - 36	70.00	52.00	1.30 (kg)	M8 x 1.25 x 20	319013

NOTE: Balance refers to a specific residual imbalance of $\leq 10 \text{ g mm/kg}$

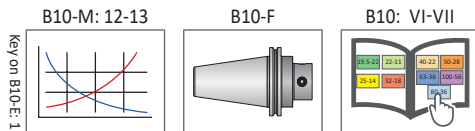

m = Metric (mm)

IMPORTANT: Max spindle speed refers to maximum possible speed for an individual boring head and is not a recommended parameter. Refer to page B10-M: 12 for recommended application-specific parameters. Factory technical assistance is available for your specific applications through our Application Engineering department. [email: engineering.eu@alliedmachine.com](mailto:engineering.eu@alliedmachine.com)

WARNING Exceeding weight capacity for machine tool spindle and tool changer can cause machine damage and/or serious injury. To prevent:
 -Consult machine tool builder for machine's weight limitations.
 -Refer to example on page B10-M: 11 for calculating tool assembly weight
 Factory technical assistance is also available for specific applications through our Application Engineering department. [email: engineering.eu@alliedmachine.com](mailto:engineering.eu@alliedmachine.com)

WARNING Tool failure can cause serious injury. To prevent:
 -Do not exceed recommended 10xD length-to-diameter ratio or exceed 4 total components (including shank)
 -When using Alu-Line® components, do not exceed recommended 5xD length-to-diameter ratio
 -When using tool steel components, do not exceed recommended 6xD length-to-diameter ratio
 -When using heavy metal components, do not exceed recommended 8xD length-to-diameter ratio
 -When using a carbide shank, do not exceed recommended 9xD length-to-diameter ratio
 -When using a NOVITECH® module, do not exceed recommended 10xD length-to-diameter ratio
 -Refer to examples on pages B10-M: 8-10 for calculating length-to-diameter ratio
 Factory technical assistance is available for your specific applications through our Application Engineering department. [email: engineering.eu@alliedmachine.com](mailto:engineering.eu@alliedmachine.com)

Heavy Metal Reducers

Vibration Reduction

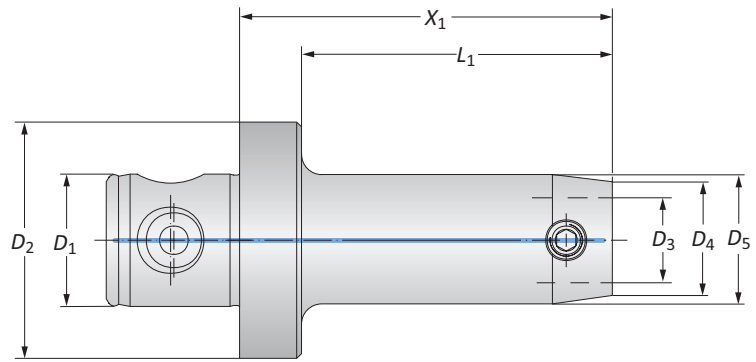

MVS Connection		Heavy Metal Reducer			Weight	Part No.
D_2 D_1	D_4 D_3	X_1	L_1	D_5		
50 - 28	19.5 - 11	90.00	77.00	–	1.00 (kg)	219055
50 - 28	22 - 11	110.00	97.00	23.00	1.30 (kg)	219056
50 - 28	25 - 14	124.00	111.00	28.00	1.70 (kg)	219057
50 - 28	25 - 14	144.00	131.00	32.00	2.30 (kg)	219058
50 - 28	25 - 14	164.00	151.00	35.00	2.90 (kg)	219059
50 - 28	32 - 18	154.00	141.00	37.00	2.90 (kg)	219093
50 - 28	32 - 18	154.00	141.00	42.00	3.70 (kg)	219060

NOTE: Heavy metal reducers are used to reduce vibration when machining deep boring applications. When using heavy metal reducers, the maximum cutting speed (V_c) is 200 M/min. If steel extensions are also used, reduce the cutting speed by 50% and use replaceable inserts where $r = 0.10$ mm.

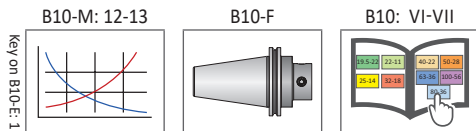

 = Metric (mm)

IMPORTANT: Max spindle speed refers to maximum possible speed for an individual boring head and is not a recommended parameter. Refer to page B10-M: 12 for recommended application-specific parameters. Factory technical assistance is available for your specific applications through our Application Engineering department. [email: engineering.eu@alliedmachine.com](mailto:engineering.eu@alliedmachine.com)

WARNING Exceeding weight capacity for machine tool spindle and tool changer can cause machine damage and/or serious injury. To prevent:
 -Consult machine tool builder for machine's weight limitations.
 -Refer to example on page B10-M: 11 for calculating tool assembly weight
 Factory technical assistance is also available for specific applications through our Application Engineering department. [email: engineering.eu@alliedmachine.com](mailto:engineering.eu@alliedmachine.com)

WARNING Tool failure can cause serious injury. To prevent:
 -Do not exceed recommended 10xD length-to-diameter ratio or exceed 4 total components (including shank)
 -When using Alu-Line® components, do not exceed recommended 5xD length-to-diameter ratio
 -When using tool steel components, do not exceed recommended 6xD length-to-diameter ratio
 -When using heavy metal components, do not exceed recommended 8xD length-to-diameter ratio
 -When using a carbide shank, do not exceed recommended 9xD length-to-diameter ratio
 -When using a NOVITECH® module, do not exceed recommended 10xD length-to-diameter ratio
 -Refer to examples on pages B10-M: 8-10 for calculating length-to-diameter ratio
 Factory technical assistance is available for your specific applications through our Application Engineering department. [email: engineering.eu@alliedmachine.com](mailto:engineering.eu@alliedmachine.com)

A
B
C
D
E
F
G
H
I
J
K
L
M
INDEX

Extensions

Balanced

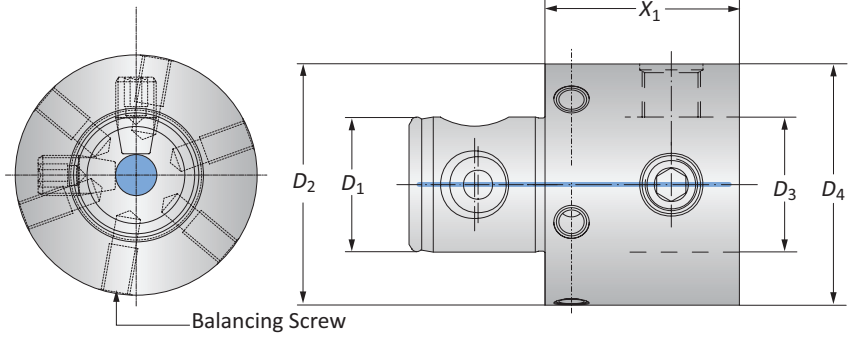

	MVS Connection		Extension	Weight	Balancing Screw	Part No.
	D ₂ D ₁	D ₄ D ₃				
	19.5 - 11	19.5 - 11	40.00	0.10 (kg)	-	219043
	22 - 11	22 - 11	40.00	0.10 (kg)	-	219044
	25 - 14	25 - 14	25.00	0.10 (kg)	-	219068
	25 - 14	25 - 14	40.00	0.10 (kg)	-	119001
	32 - 18	32 - 18	40.00	0.20 (kg)	-	119002
	40 - 22	40 - 22	40.00	0.40 (kg)	-	119003
	50 - 28	50 - 28	40.00	0.60 (kg)	M6 x 1 x 10	119004
	50 - 28*	50 - 28*	75.00	1.10 (kg)	M6 x 1 x 10	219097
	50 - 28	50 - 28	75.00	1.10 (kg)	M6 x 1 x 10	219082
	50 - 28	50 - 28	100.00	1.50 (kg)	M6 x 1 x 10	119058
Ⓜ	63 - 36	63 - 36	50.00	1.10 (kg)	M6 x 1 x 10	119005
	63 - 36	63 - 36	75.00	1.70 (kg)	M6 x 1 x 15	219083
	63 - 36	63 - 36	125.00	2.90 (kg)	M6 x 1 x 15	119065
	80 - 36	80 - 36	50.00	1.90 (kg)	M6 x 1 x 15	119006
	80 - 36	80 - 36	75.00	2.80 (kg)	M6 x 1 x 15	219084
	80 - 36	80 - 36	125.00	4.80 (kg)	M6 x 1 x 15	119066
	80 - 36	80 - 36	200.00	7.40 (kg)	M8 x 1.25 x 21	219094
	80 - 36	80 - 36	275.00	10.10 (kg)	M8 x 1.25 x 21	119069
	100 - 56	100 - 56	75.00	4.30 (kg)	M8 x 1.25 x 20	219095
	100 - 56	100 - 56	100.00	5.60 (kg)	M8 x 1.25 x 20	219061
	100 - 56	100 - 56	150.00	8.10 (kg)	M8 x 1.25 x 20	219096
	100 - 56	100 - 56	200.00	10.20 (kg)	M8 x 1.25 x 20	219062
	100 - 56	100 - 56	300.00	14.60 (kg)	M8 x 1.25 x 20	219063

*D₂ / D₄ = 49.50 mm for boring 50.00 mm diameter applications
 NOTE: Balance refers to a specific residual imbalance of ≤ 10 g mm/kg

B10-M: 12-13

B10-F

B10: VI-VII

Key on B10-E: 1

Ⓜ = Metric (mm)

IMPORTANT: Max spindle speed refers to maximum possible speed for an individual boring head and is not a recommended parameter. Refer to page B10-M: 12 for recommended application-specific parameters. Factory technical assistance is available for your specific applications through our Application Engineering department. email: engineering.eu@alliedmachine.com

⚠ WARNING Exceeding weight capacity for machine tool spindle and tool changer can cause machine damage and/or serious injury. To prevent:
 -Consult machine tool builder for machine's weight limitations.
 -Refer to example on page B10-M: 11 for calculating tool assembly weight
 Factory technical assistance is also available for specific applications through our Application Engineering department. email: engineering.eu@alliedmachine.com

⚠ WARNING Tool failure can cause serious injury. To prevent:
 -Do not exceed recommended 10xD length-to-diameter ratio or exceed 4 total components (including shank)
 -When using Alu-Line® components, do not exceed recommended 5xD length-to-diameter ratio
 -When using tool steel components, do not exceed recommended 6xD length-to-diameter ratio
 -When using heavy metal components, do not exceed recommended 8xD length-to-diameter ratio
 -When using a carbide shank, do not exceed recommended 9xD length-to-diameter ratio
 -When using a NOVITECH® module, do not exceed recommended 10xD length-to-diameter ratio
 -Refer to examples on pages B10-M: 8-10 for calculating length-to-diameter ratio
 Factory technical assistance is available for your specific applications through our Application Engineering department. email: engineering.eu@alliedmachine.com

Extensions

Balanced Alu-Line

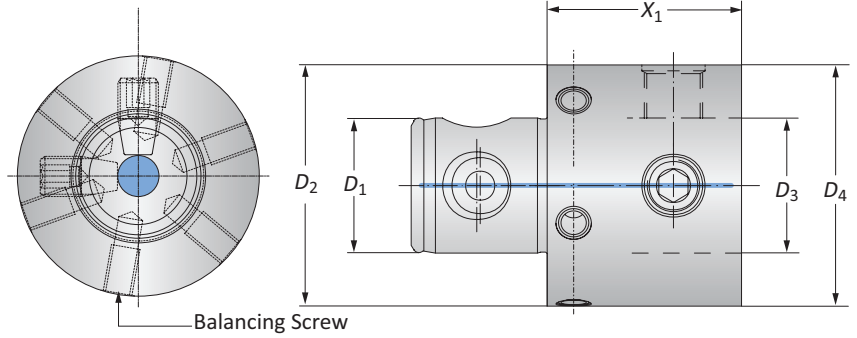

MVS Connection		Modules				
D_2 D_1	D_4 D_3	X_1	Weight	Balancing Screw	Part No.	
50 - 28	50 - 28	40.00	0.20 (kg)	M6 x 1 x 8	319021	
50 - 28	50 - 28	75.00	0.40 (kg)	M6 x 1 x 10	319022	
50 - 28	50 - 28	100.00	0.60 (kg)	M6 x 1 x 10	319023	
63 - 36	63 - 36	50.00	0.40 (kg)	M6 x 1 x 8	319002	
63 - 36	63 - 36	125.00	1.10 (kg)	M6 x 1 x 10	319003	
80 - 36	80 - 36	50.00	0.70 (kg)	M6 x 1 x 10	319004	
80 - 36	80 - 36	75.00	1.00 (kg)	M6 x 1 x 10	319016	
80 - 36	80 - 36	125.00	1.80 (kg)	M6 x 1 x 10	319005	
80 - 36	80 - 36	200.00	2.70 (kg)	M6 x 1 x 10	319017	
80 - 36	80 - 36	275.00	3.70 (kg)	M6 x 1 x 10	319006	
100 - 56	100 - 56	75.00	1.50 (kg)	M8 x 1.25 x 20	319019	
100 - 56	100 - 56	100.00	2.20 (kg)	M8 x 1.25 x 20	319007	
100 - 56	100 - 56	150.00	3.00 (kg)	M8 x 1.25 x 20	319018	
100 - 56	100 - 56	200.00	3.80 (kg)	M8 x 1.25 x 20	319008	
100 - 56	100 - 56	300.00	5.40 (kg)	M8 x 1.25 x 20	319009	

NOTE: Balance refers to a specific residual imbalance of ≤ 10 g mm/kg

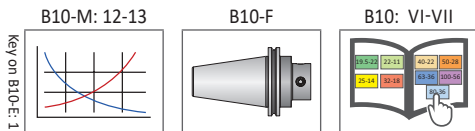

mm = Metric (mm)

IMPORTANT: Max spindle speed refers to maximum possible speed for an individual boring head and is not a recommended parameter. Refer to page B10-M: 12 for recommended application-specific parameters. Factory technical assistance is available for your specific applications through our Application Engineering department. [email: engineering.eu@alliedmachine.com](mailto:engineering.eu@alliedmachine.com)

WARNING Exceeding weight capacity for machine tool spindle and tool changer can cause machine damage and/or serious injury. To prevent:
 -Consult machine tool builder for machine's weight limitations.
 -Refer to example on page B10-M: 11 for calculating tool assembly weight
 Factory technical assistance is also available for specific applications through our Application Engineering department. [email: engineering.eu@alliedmachine.com](mailto:engineering.eu@alliedmachine.com)

WARNING Tool failure can cause serious injury. To prevent:
 -Do not exceed recommended 10xD length-to-diameter ratio or exceed 4 total components (including shank)
 -When using Alu-Line® components, do not exceed recommended 5xD length-to-diameter ratio
 -When using tool steel components, do not exceed recommended 6xD length-to-diameter ratio
 -When using heavy metal components, do not exceed recommended 8xD length-to-diameter ratio
 -When using a carbide shank, do not exceed recommended 9xD length-to-diameter ratio
 -When using a NOVITECH® module, do not exceed recommended 10xD length-to-diameter ratio
 -Refer to examples on pages B10-M: 8-10 for calculating length-to-diameter ratio
 Factory technical assistance is available for your specific applications through our Application Engineering department. [email: engineering.eu@alliedmachine.com](mailto:engineering.eu@alliedmachine.com)

SECTION

B10-F

Master Shanks with MVS Connection

Wohlhaupter® Master Shanks with MVS Connection



The MVS Connection

Wohlhaupter MVS connection shanks provide a high level of accuracy when building or replacing components. Our master shanks adapt to any machine tool spindle, making it easy to find the shank you need.

Your safety and the safety of others is very important. This catalogue contains important safety messages. Always read and follow all safety precautions.



This triangle is a safety hazard symbol. It alerts you to potential safety hazards that can cause tool failure and serious injury.

When you see this symbol in the catalogue, look for a related safety message that may be near this triangle or referred to in the nearby text.

There are safety signal words also used in the catalogue. Safety messages follow these words.

WARNING

WARNING (shown above) means that failure to follow the precautions in this message could result in tool failure and serious injury.

NOTICE means that failure to follow the precautions in this message could result in damage to the tool or machine but not result in personal injury.

NOTE and **IMPORTANT** are also used. These are important that you read and follow but are not safety-related.

Visit www.alliedmachine.com for the most up-to-date information and procedures.

Applicable Industries



Aerospace



Agriculture



Automotive



Firearms



General
Machining



Oil & Gas



Renewable
Energy

Master Shanks with MVS Connection Table of Contents

Reference Icons

The following icons will appear throughout the catalogue to help you navigate between products.

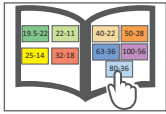

MVS Connection Colour Guide
Detailed instructions and information regarding the MVS connection(s)

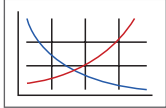

Recommended Cutting Data
Speed and feed recommendations for optimum and safe boring

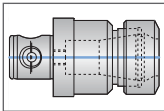

Clamping Elements
Collet chucks for carbide shanks



Through Coolant Option
Indicates that the product is through coolant

248 Shanks	2
Carbide Shanks	3
HSK Shanks (DIN 69893)	4
Polygon Shaft Shanks (PSC) (ISO26623-1)	5
CAT Shanks with Metric Threads	6
Dual Contact SK Shanks (DIN 69871-AD / BD)	7
SK Shanks (DIN 69871-AD / B-D)	8
Dual Contact BT Shanks (JIS B 6339)	9
BT Shanks (JIS B 6339)	10
NMTB Shanks	11
DIN 2080 Shanks	12
Morse Taper Shanks (DIN 1806) & R8 Shanks	13
Accessories	14 - 15
Mounting Fixtures	16

248 Shanks

Steel | Carbide

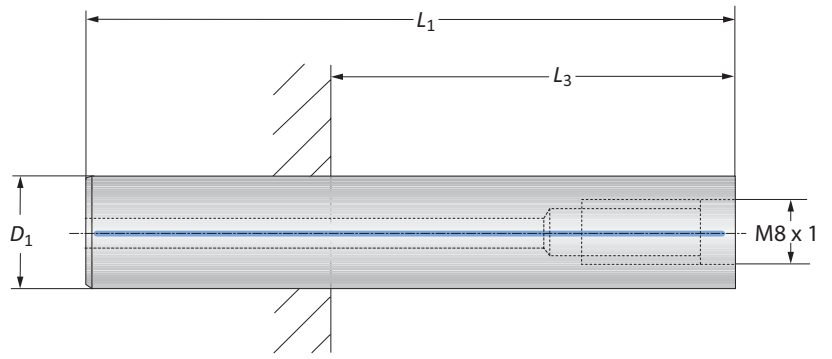

Steel Shanks

Connection	Shank			L_3 min*				Weight	Part No.
	D_1	L_1	L_3 max*	SK 40+50	HSK-A 63	HSK-A 100			
M8 x 1	15.00	85.00	37.00	-	-	-	0.10 (kg)	248136	
M8 x 1	18.00	100.00	52.00	-	5.00	12.00	0.20 (kg)	248137	
M8 x 1	23.00	117.00	69.00	-	22.00	29.00	0.40 (kg)	248138	

* L_3 dimensions apply to collet chucks

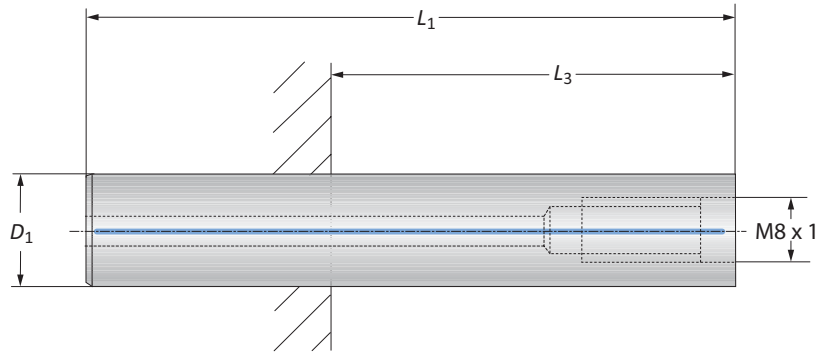

Carbide Shanks

Connection	Shank			L_3 min*				Weight	Part No.
	D_1	L_1	L_3 max*	SK 40	SK 50	HSK-A 63	HSK-A 100		
M8 x 1	15.00	130.00	82.00	20.00	20.00	35.00	42.00	0.30 (kg)	248142
M8 x 1	18.00	155.00	107.00	39.00	21.00	60.00	67.00	0.60 (kg)	248143
M8 x 1	23.00	180.00	132.00	64.00	46.00	85.00	92.00	1.10 (kg)	248144
M8 x 1	23.00	242.00	194.00	126.00	108.00	147.00	154.00	1.40 (kg)	248145

* L_3 dimensions apply to collet chucks

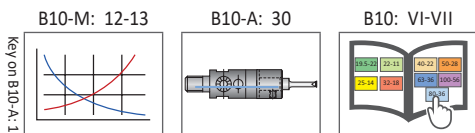

Ⓜ = Metric (mm)

⚠ WARNING Exceeding weight capacity for machine tool spindle and tool changer can cause machine damage and/or serious injury. To prevent:

- Consult machine tool builder for machine's weight limitations.
- Refer to example on page B10-M: 11 for calculating tool assembly weight
- Factory technical assistance is also available for specific applications through our Application Engineering department. *email: engineering.eu@alliedmachine.com*

⚠ WARNING Tool failure can cause serious injury. To prevent:

- Do not exceed recommended 10xD length-to-diameter ratio or exceed 4 total components (including shank)
- When using Alu-Line® components, do not exceed recommended 5xD length-to-diameter ratio
- When using tool steel components, do not exceed recommended 6xD length-to-diameter ratio
- When using heavy metal reducers, do not exceed recommended 8xD length-to-diameter ratio
- When using a carbide shank, do not exceed recommended 9xD length-to-diameter ratio
- When using a NOVITECH® module, do not exceed recommended 10xD length-to-diameter ratio
- Refer to examples on pages B10-M: 8-10 for calculating length-to-diameter ratio
- Factory technical assistance is available for your specific applications through our Application Engineering department. *email: engineering.eu@alliedmachine.com*

A
B
C
D
E
F
G
H
I
J
K
L
M
INDEX



Carbide Master Shanks

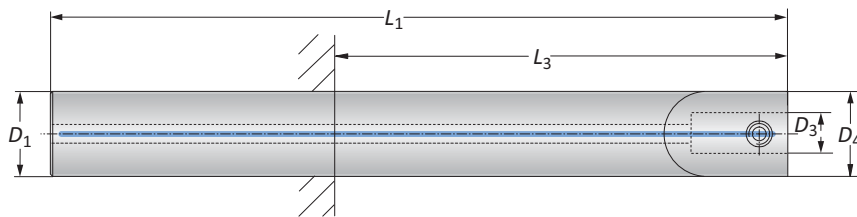

Connection	Shank			L_3 min				Weight	Part No.	
	D_4 D_3	L_1	D_1	L_3 max	SK 40	SK 50	HSK-A 63			HSK-A 100
M	18 - 11	155.00	18.00	107.00	39.00	26.00	60.00	67.00	0.50 (kg)	299009*
	22 - 11	140.00	22.00	92.00	28.00	28.00	45.00	52.00	0.70 (kg)	299001*
	22 - 11	190.00	22.00	142.00	74.00	56.00	95.00	102.00	0.90 (kg)	299002*
	22 - 11	231.00	22.00	183.00	115.00	97.00	136.00	143.00	1.10 (kg)	299003*
	25 - 14	165.00	25.00	117.00	49.00	36.00	70.00	77.00	1.00 (kg)	299004*
	25 - 14	215.00	25.00	167.00	99.00	81.00	120.00	127.00	1.30 (kg)	299005*
	32 - 18	210.00	32.00	-	136.00	136.00	139.00	137.00	2.10 (kg)	299006**
	32 - 18	260.00	32.00	-	186.00	186.00	189.00	187.00	2.60 (kg)	299007**
40 - 22	415.00	40.00	-	-	333.00	-	333.00	5.20 (kg)	299008**	

NOTE: Adapter shanks are used for extensions up to 10xD

*Recommended clamping element: collet chuck ISO 15488 (DIN 6499-B) (pg. B10-I: 5)

**Recommended clamping element: collet chuck ISO 10897 (DIN 6388) (pg. B10-I: 5)

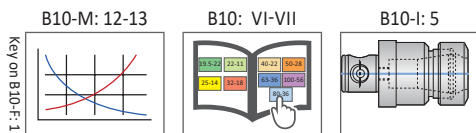

M = Metric (mm)

WARNING Exceeding weight capacity for machine tool spindle and tool changer can cause machine damage and/or serious injury. To prevent:

- Consult machine tool builder for machine's weight limitations.
- Refer to example on page B10-M: 11 for calculating tool assembly weight
- Factory technical assistance is also available for specific applications through our Application Engineering department. *email: engineering.eu@alliedmachine.com*

WARNING Tool failure can cause serious injury. To prevent:

- Do not exceed recommended 10xD length-to-diameter ratio or exceed 4 total components (including shank)
- When using Alu-Line® components, do not exceed recommended 5xD length-to-diameter ratio
- When using tool steel components, do not exceed recommended 6xD length-to-diameter ratio
- When using heavy metal reducers, do not exceed recommended 8xD length-to-diameter ratio
- When using a carbide shank, do not exceed recommended 9xD length-to-diameter ratio
- When using a NOVI^{TECH}® module, do not exceed recommended 10xD length-to-diameter ratio
- Refer to examples on pages B10-M: 8-10 for calculating length-to-diameter ratio
- Factory technical assistance is available for your specific applications through our Application Engineering department. *email: engineering.eu@alliedmachine.com*

HSK Master Shanks (DIN 69893)

Balanced

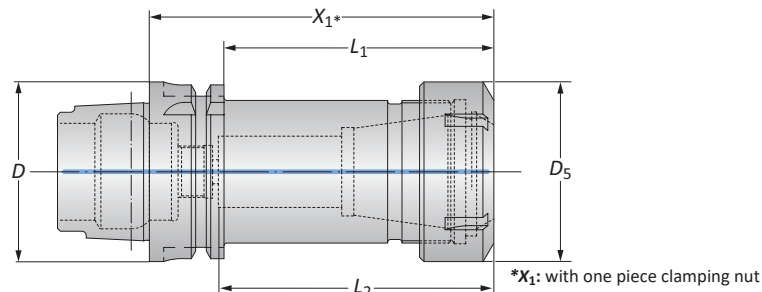
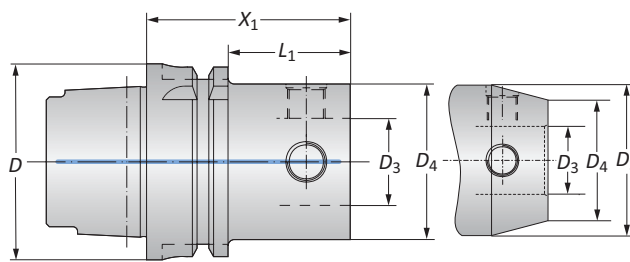

Taper Size	Connection	Shank				Weight	Part No.
		D	D ₄ D ₃	X ₁	L ₁		
40	40 - 22	40	56.00	-	-	0.40 (kg)	246016
40	50 - 28	40	70.00	-	-	0.70 (kg)	246004
50	40 - 22	50	56.00	30.00	-	0.60 (kg)	246015
50	50 - 28	50	65.00	-	-	0.80 (kg)	245011
63	25 - 14	63	46.00	20.00	-	0.70 (kg)	246012
63	32 - 18	63	56.00	30.00	-	0.80 (kg)	246013
63	40 - 22	63	56.00	30.00	-	0.80 (kg)	246014
63	50 - 28	63	65.00	39.00	-	1.10 (kg)	245012
63	63 - 36	63	80.00	-	-	1.50 (kg)	245013
63	80 - 36	63	80.00	-	-	2.10 (kg)	246009
63	ER 40	63	120.00	94.00	95.00	1.70 (kg)	252090**
100	50 - 28	100	65.00	36.00	-	2.40 (kg)	245014
100	50 - 28	100	180.00	151.00	-	5.00 (kg)	246020
100	50 - 28*	100	180.00	151.00	-	4.00 (kg)	246021
100	63 - 36	100	80.00	51.00	-	2.90 (kg)	245015
100	63 - 36	100	205.00	176.00	-	7.80 (kg)	246019
100	63 - 36	100	205.00	176.00	-	7.80 (kg)	246022
100	80 - 36	100	80.00	51.00	-	3.70 (kg)	245016
100	80 - 36	100	255.00	226.00	-	12.60 (kg)	246018
100	80 - 36	100	255.00	226.00	-	10.40 (kg)	246023
100	100 - 56	100	100.00	-	-	5.00 (kg)	246010
100	100 - 56	100	300.00	221.00	-	17.50 (kg)	246017
100	ER 40	100	120.00	91.00	88.00	3.50 (kg)	252091**

NOTE: Balanced refers to a specific residual imbalance of ≤4.00 gmm/kg

*D₄ = 49.50 mm

**Balanced without clamping nut

B10-M: 12-13

B10: VI-VII

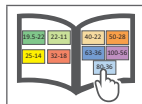
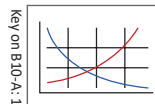

Ⓜ = Metric (mm)

⚠ WARNING Exceeding weight capacity for machine tool spindle and tool changer can cause machine damage and/or serious injury. To prevent:

-Consult machine tool builder for machine's weight limitations.

-Refer to example on page B10-M: 11 for calculating tool assembly weight

Factory technical assistance is also available for specific applications through our Application Engineering department. *email: engineering.eu@alliedmachine.com*

⚠ WARNING Tool failure can cause serious injury. To prevent:

-Do not exceed recommended 10xD length-to-diameter ratio or exceed 4 total components (including shank)

-When using Alu-Line® components, do not exceed recommended 5xD length-to-diameter ratio

-When using tool steel components, do not exceed recommended 6xD length-to-diameter ratio

-When using heavy metal reducers, do not exceed recommended 8xD length-to-diameter ratio

-When using a carbide shank, do not exceed recommended 9xD length-to-diameter ratio

-When using a NOVITECH® module, do not exceed recommended 10xD length-to-diameter ratio

-Refer to examples on pages B10-M: 8-10 for calculating length-to-diameter ratio

Factory technical assistance is available for your specific applications through our Application Engineering department. *email: engineering.eu@alliedmachine.com*

Polygon Shaft Master Shanks (PSC) (ISO 26623-1)

Balanced

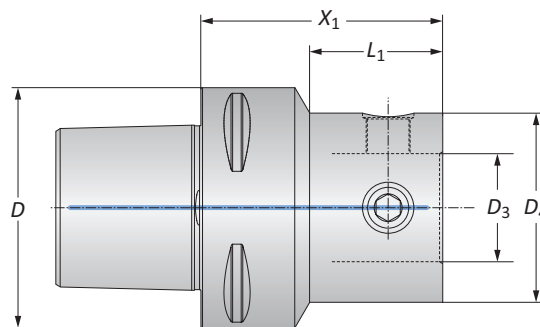
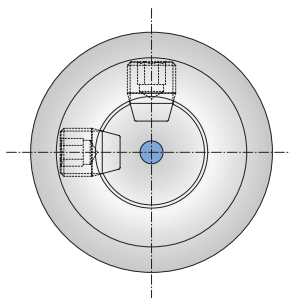

PSC	Connection	Shank		Weight	Part No.	
		D	$D_4 D_3$			X_1
m	50	40 - 22	54.00	31.10	0.70 (kg)	227014
	50	50 - 28	65.00	-	1.00 (kg)	227001
	50	63 - 36	80.00	-	1.50 (kg)	227002
	50	80 - 36	80.00	-	2.50 (kg)	227012
	63	25 - 14	54.00	21.10	0.90 (kg)	227010
	63	32 - 18	54.00	23.00	1.00 (kg)	227009
	63	40 - 22	65.00	36.40	1.10 (kg)	227008
	63	50 - 28	65.00	39.00	1.30 (kg)	227003
	63	63 - 36	80.00	-	1.80 (kg)	227004
	63	80 - 36	80.00	-	2.60 (kg)	227005
	80	50 - 28	65.00	25.00	2.20 (kg)	227011
	80	63 - 36	80.00	45.10	2.60 (kg)	227006
	80	80 - 36	80.00	-	3.30 (kg)	227007

NOTE: Balanced refers to a specific residual imbalance of ≤ 4.00 gmm/kg

B10-M: 12-13

B10: VI-VII

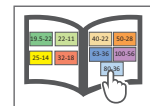
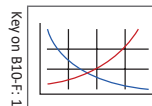

m = Metric (mm)

WARNING Exceeding weight capacity for machine tool spindle and tool changer can cause machine damage and/or serious injury. To prevent:

- Consult machine tool builder for machine's weight limitations.
- Refer to example on page B10-M: 11 for calculating tool assembly weight
- Factory technical assistance is also available for specific applications through our Application Engineering department. *email: engineering.eu@alliedmachine.com*

WARNING Tool failure can cause serious injury. To prevent:

- Do not exceed recommended 10xD length-to-diameter ratio or exceed 4 total components (including shank)
- When using Alu-Line® components, do not exceed recommended 5xD length-to-diameter ratio
- When using tool steel components, do not exceed recommended 6xD length-to-diameter ratio
- When using heavy metal reducers, do not exceed recommended 8xD length-to-diameter ratio
- When using a carbide shank, do not exceed recommended 9xD length-to-diameter ratio
- When using a NOVI^{TECH}® module, do not exceed recommended 10xD length-to-diameter ratio
- Refer to examples on pages B10-M: 8-10 for calculating length-to-diameter ratio
- Factory technical assistance is available for your specific applications through our Application Engineering department. *email: engineering.eu@alliedmachine.com*

CAT Master Shanks with Metric Threads

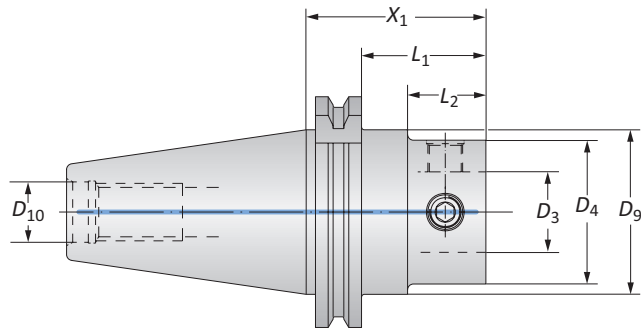

Taper Size	Connection $D_4 D_3$	Shank					Weight	Part No.
		X_1	L_1	L_2	D_9	D_{10}		
40	50 - 28	62.00	42.90	-	44.45	M16 x 2	1.30 (kg)	132022T016960
40	63 - 36	82.00	62.90	-	44.45	M16 x 2	1.80 (kg)	132066T016960
50	50 - 28	62.00	42.90	27.00	69.85	M24 x 3	3.40 (kg)	132022T016962
50	63 - 36	72.00	52.90	37.00	69.85	M24 x 3	3.70 (kg)	132066T016962
50	80 - 36	72.00	52.90	-	69.85	M24 x 3	4.20 (kg)	132088T016962
50	100 - 56	105.00	85.90	-	69.85	M24 x 3	5.20 (kg)	132076T016962

Ⓜ

B10-M: 12-13

B10: VI-VII

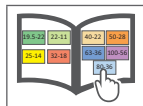
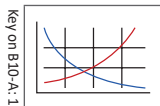

Ⓜ = Metric (mm)

⚠ WARNING Exceeding weight capacity for machine tool spindle and tool changer can cause machine damage and/or serious injury. To prevent:

- Consult machine tool builder for machine's weight limitations.
 - Refer to example on page B10-M: 11 for calculating tool assembly weight
- Factory technical assistance is also available for specific applications through our Application Engineering department. *email: engineering.eu@alliedmachine.com*

⚠ WARNING Tool failure can cause serious injury. To prevent:

- Do not exceed recommended 10xD length-to-diameter ratio or exceed 4 total components (including shank)
 - When using Alu-Line® components, do not exceed recommended 5xD length-to-diameter ratio
 - When using tool steel components, do not exceed recommended 6xD length-to-diameter ratio
 - When using heavy metal reducers, do not exceed recommended 8xD length-to-diameter ratio
 - When using a carbide shank, do not exceed recommended 9xD length-to-diameter ratio
 - When using a NOVITECH® module, do not exceed recommended 10xD length-to-diameter ratio
 - Refer to examples on pages B10-M: 8-10 for calculating length-to-diameter ratio
- Factory technical assistance is available for your specific applications through our Application Engineering department. *email: engineering.eu@alliedmachine.com*

A
B
C
D
E
F
G
H
I
J
K
L
M
INDEX

Dual Contact SK Master Shanks (DIN 69871-AD / B-D)

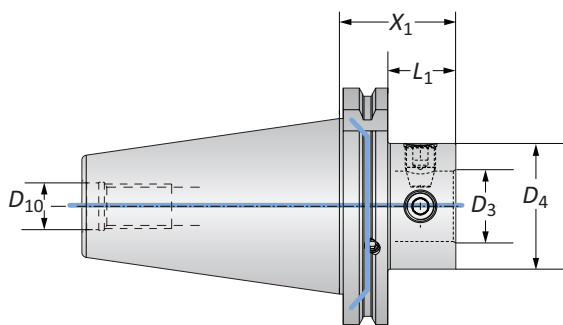

Taper Size	Connection	Shank			Weight	Part No.	
	$D_4 D_3$	X_1	L_1	D_{10}			
m	40	50 - 28	46.00	26.90	M16 x 2	1.10 (kg)	353064
	40	63 - 36	66.00	46.90	M16 x 2	1.50 (kg)	353065
	50	50 - 28	46.00	26.90	M24 x 3	2.90 (kg)	353066
	50	63 - 36	56.00	36.90	M24 x 3	3.20 (kg)	353067
	50	80 - 36	56.00	36.90	M24 x 3	3.70 (kg)	353068
	50	100 - 56	90.00	70.90	M24 x 3	5.30 (kg)	353069

B10-M: 12-13

B10: VI-VII

Key on B10-F: 1

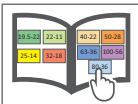
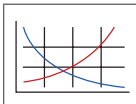

m = Metric (mm)

WARNING Exceeding weight capacity for machine tool spindle and tool changer can cause machine damage and/or serious injury. To prevent:

- Consult machine tool builder for machine's weight limitations.
 - Refer to example on page B10-M: 11 for calculating tool assembly weight
- Factory technical assistance is also available for specific applications through our Application Engineering department. *email: engineering.eu@alliedmachine.com*

WARNING Tool failure can cause serious injury. To prevent:

- Do not exceed recommended 10xD length-to-diameter ratio or exceed 4 total components (including shank)
 - When using Alu-Line® components, do not exceed recommended 5xD length-to-diameter ratio
 - When using tool steel components, do not exceed recommended 6xD length-to-diameter ratio
 - When using heavy metal reducers, do not exceed recommended 8xD length-to-diameter ratio
 - When using a carbide shank, do not exceed recommended 9xD length-to-diameter ratio
 - When using a NOVI^{TECH}® module, do not exceed recommended 10xD length-to-diameter ratio
 - Refer to examples on pages B10-M: 8-10 for calculating length-to-diameter ratio
- Factory technical assistance is available for your specific applications through our Application Engineering department. *email: engineering.eu@alliedmachine.com*

SK Master Shanks (DIN 69871-AD / B-D)

Balanced

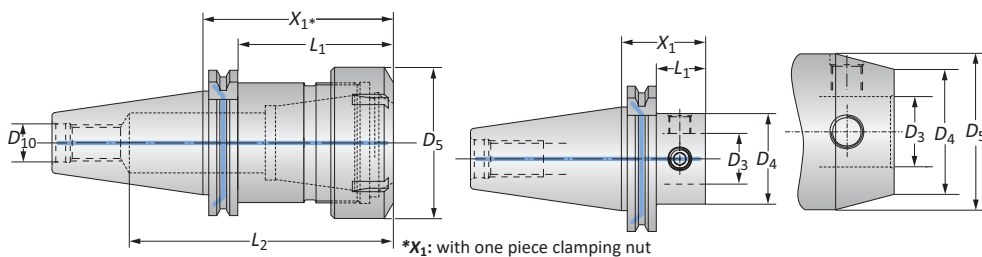

Taper Size	Connection <i>D</i> ₄ <i>D</i> ₃	Shank					Weight	Part No.
		<i>X</i> ₁	<i>L</i> ₁	<i>L</i> ₂	<i>D</i> ₅	<i>D</i> ₁₀		
30	40 - 22	46.00	26.90	-	-	M12 x 1.75	0.50 (kg)	327001
30	50 - 28	58.00	38.90	-	-	M12 x 1.75	0.80 (kg)	327002
40	32 - 18	55.00	35.90	-	40.00	M16 x 2	1.10 (kg)	327003
40	40 - 22	46.00	26.90	-	-	M16 x 2	1.00 (kg)	327004
40	50 - 28	46.00	26.90	-	-	M16 x 2	1.10 (kg)	327005
40	63 - 36	66.00	46.90	-	-	M16 x 2	1.40 (kg)	327006
40	80 - 36	66.00	46.90	-	-	M16 x 2	1.90 (kg)	327007
40	ER 40	80.00	60.90	116.00	63.00	M16 x 2	1.30 (kg)	259079**
50	50 - 28	46.00	26.90	-	-	M24 x 3	2.90 (kg)	327017
50	50 - 28	186.00	166.90	-	60.00	M24 x 3	6.00 (kg)	327025
50	50 - 28*	186.00	166.90	-	-	M24 x 3	4.90 (kg)	327033
50	63 - 36	56.00	36.90	-	-	M24 x 3	3.20 (kg)	327018
50	63 - 36	206.00	186.90	-	78.00	M24 x 3	8.90 (kg)	327026
50	63 - 36	206.00	186.90	-	-	M24 x 3	6.90 (kg)	327034
50	80 - 36	56.00	36.90	-	-	M24 x 3	3.70 (kg)	327010
50	80 - 36	256.00	236.90	-	90.00	M24 x 3	13.60 (kg)	327027
50	100 - 56	90.00	70.90	-	-	M24 x 3	5.30 (kg)	327011
50	100 - 56	290.00	270.90	-	-	M24 x 3	17.10 (kg)	327028
50	ER 40	80.00	55.20	134.00	63.00	M24 x 3	3.10 (kg)	259080**

NOTE: Balanced refers to a specific residual imbalance of ≤4.00 gmm/kg

* *D*₄ = (49.50 mm)

**Balanced without clamping nut

B10-M: 12-13

B10: VI-VII

Key on B10-A:1

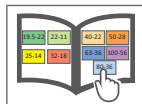
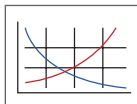

Ⓜ = Metric (mm)

⚠ WARNING Exceeding weight capacity for machine tool spindle and tool changer can cause machine damage and/or serious injury. To prevent:

- Consult machine tool builder for machine's weight limitations.
- Refer to example on page B10-M: 11 for calculating tool assembly weight
- Factory technical assistance is also available for specific applications through our Application Engineering department. *email: engineering.eu@alliedmachine.com*

⚠ WARNING Tool failure can cause serious injury. To prevent:

- Do not exceed recommended 10xD length-to-diameter ratio or exceed 4 total components (including shank)
- When using Alu-Line® components, do not exceed recommended 5xD length-to-diameter ratio
- When using tool steel components, do not exceed recommended 6xD length-to-diameter ratio
- When using heavy metal reducers, do not exceed recommended 8xD length-to-diameter ratio
- When using a carbide shank, do not exceed recommended 9xD length-to-diameter ratio
- When using a NOVITECH® module, do not exceed recommended 10xD length-to-diameter ratio
- Refer to examples on pages B10-M: 8-10 for calculating length-to-diameter ratio
- Factory technical assistance is available for your specific applications through our Application Engineering department. *email: engineering.eu@alliedmachine.com*

A
B
C
D
E
F
G
H
I
J
K
L
M
INDEX

Dual Contact BT Master Shanks (JIS B 6339)

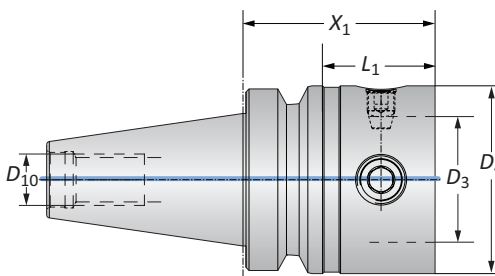

Taper Size	Connection		Shank			Weight	Part No.
	D_4 D_3	X_1	L_1	D_{10}			
mm	40	50 - 28	54.00	27.00	M16 x 2	1.20 (kg)	353070
	40	63 - 36	64.00	37.00	M16 x 2	1.50 (kg)	353071
	50	50 - 28	65.00	26.80	M24 x 3	4.00 (kg)	353072
	50	63 - 36	75.00	36.80	M24 x 3	4.20 (kg)	353073
	50	80 - 36	75.00	36.80	M24 x 3	4.80 (kg)	353074
	50	100 - 56	90.00	51.80	M24 x 3	5.50 (kg)	353075

B10-M: 12-13

B10: VI-VII

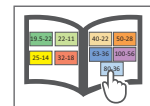
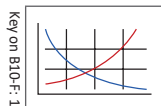

mm = Metric (mm)

WARNING Exceeding weight capacity for machine tool spindle and tool changer can cause machine damage and/or serious injury. To prevent:

- Consult machine tool builder for machine's weight limitations.
 - Refer to example on page B10-M: 11 for calculating tool assembly weight
- Factory technical assistance is also available for specific applications through our Application Engineering department. *email: engineering.eu@alliedmachine.com*

WARNING Tool failure can cause serious injury. To prevent:

- Do not exceed recommended 10xD length-to-diameter ratio or exceed 4 total components (including shank)
 - When using Alu-Line® components, do not exceed recommended 5xD length-to-diameter ratio
 - When using tool steel components, do not exceed recommended 6xD length-to-diameter ratio
 - When using heavy metal reducers, do not exceed recommended 8xD length-to-diameter ratio
 - When using a carbide shank, do not exceed recommended 9xD length-to-diameter ratio
 - When using a NOVI^{TECH}® module, do not exceed recommended 10xD length-to-diameter ratio
 - Refer to examples on pages B10-M: 8-10 for calculating length-to-diameter ratio
- Factory technical assistance is available for your specific applications through our Application Engineering department. *email: engineering.eu@alliedmachine.com*

BT Master Shanks (JIS B 6339)

Balanced

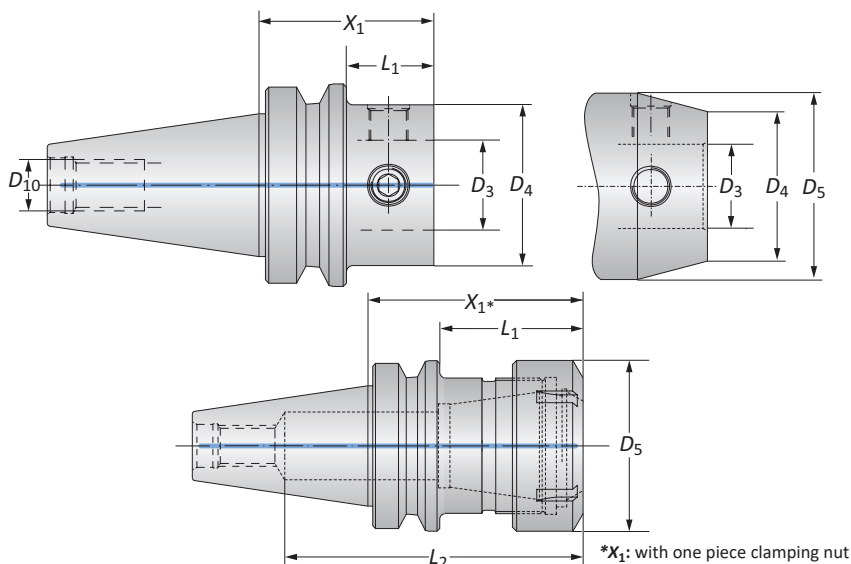

Taper Size	Connection $D_4 D_3$	Shank					Weight	Part No.
		X_1	L_1	L_2	D_5	D_{10}		
30	40 - 22	40.00	18.00	-	-	M12 x 1.75	0.50 (kg)	327012
30	50 - 28	46.00	24.00	-	-	M12 x 1.75	0.60 (kg)	327013
40	40 - 22	46.00	19.00	-	-	M16 x 2	1.10 (kg)	327016
40	50 - 28	54.00	27.00	-	-	M16 x 2	1.20 (kg)	327019
40	63 - 36	64.00	37.00	-	-	M16 x 2	1.50 (kg)	327020
m 40	ER 40	70.00	43.00	104.00	63.00	M16 x 2	1.20 (kg)	259081*
50	50 - 28	65.00	26.80	-	-	M24 x 3	3.90 (kg)	327021
50	63 - 36	75.00	36.80	-	-	M24 x 3	4.20 (kg)	327022
50	80 - 36	75.00	36.80	-	-	M24 x 3	4.70 (kg)	327023
50	100 - 56	90.00	51.80	-	-	M24 x 3	5.50 (kg)	327024
50	ER 40	80.00	41.80	135.00	63.00	M24 x 3	3.80 (kg)	259082*

NOTE: Balanced refers to a specific residual imbalance of ≤ 4.00 gmm/kg

*Balanced without clamping nut

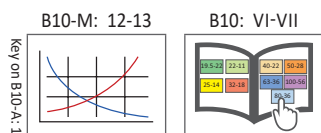

m = Metric (mm)

WARNING Exceeding weight capacity for machine tool spindle and tool changer can cause machine damage and/or serious injury. To prevent:

- Consult machine tool builder for machine's weight limitations.
- Refer to example on page B10-M: 11 for calculating tool assembly weight
- Factory technical assistance is also available for specific applications through our Application Engineering department. *email: engineering.eu@alliedmachine.com*

WARNING Tool failure can cause serious injury. To prevent:

- Do not exceed recommended 10xD length-to-diameter ratio or exceed 4 total components (including shank)
- When using Alu-Line® components, do not exceed recommended 5xD length-to-diameter ratio
- When using tool steel components, do not exceed recommended 6xD length-to-diameter ratio
- When using heavy metal reducers, do not exceed recommended 8xD length-to-diameter ratio
- When using a carbide shank, do not exceed recommended 9xD length-to-diameter ratio
- When using a NOVITECH® module, do not exceed recommended 10xD length-to-diameter ratio
- Refer to examples on pages B10-M: 8-10 for calculating length-to-diameter ratio
- Factory technical assistance is available for your specific applications through our Application Engineering department. *email: engineering.eu@alliedmachine.com*

NMTB Master Shanks

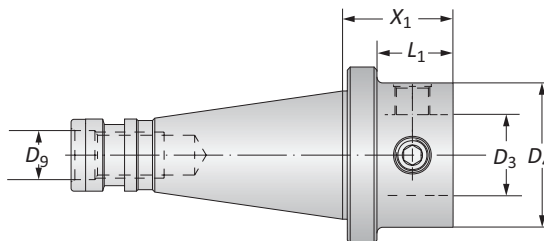

Taper Size	Connection		Shank			Weight	Part No.
	D_4 D_3	X_1	L_1	D_9			
M	40	50 - 28	38.00	26.40	$\frac{5}{8}$ - 11	1.30 (kg)	132022T004498
	40	63 - 36	48.00	36.40	$\frac{5}{8}$ - 11	1.50 (kg)	132066T004498
	50	50 - 28	42.00	26.80	1 - 8	3.00 (kg)	132022T004480
	50	63 - 36	52.00	36.80	1 - 8	3.50 (kg)	132066T004480
	50	80 - 36	52.00	36.80	1 - 8	4.00 (kg)	132088T004480
50	100 - 56	90.00	74.80	1 - 8	4.90 (kg)	132076T004480	

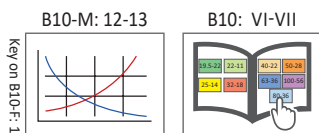

M = Metric (mm)

WARNING Exceeding weight capacity for machine tool spindle and tool changer can cause machine damage and/or serious injury. To prevent:
 -Consult machine tool builder for machine's weight limitations.
 -Refer to example on page B10-M: 11 for calculating tool assembly weight
 Factory technical assistance is also available for specific applications through our Application Engineering department. *email: engineering.eu@alliedmachine.com*

WARNING Tool failure can cause serious injury. To prevent:
 -Do not exceed recommended 10xD length-to-diameter ratio or exceed 4 total components (including shank)
 -When using Alu-Line® components, do not exceed recommended 5xD length-to-diameter ratio
 -When using tool steel components, do not exceed recommended 6xD length-to-diameter ratio
 -When using heavy metal reducers, do not exceed recommended 8xD length-to-diameter ratio
 -When using a carbide shank, do not exceed recommended 9xD length-to-diameter ratio
 -When using a NOVI^{TECH}® module, do not exceed recommended 10xD length-to-diameter ratio
 -Refer to examples on pages B10-M: 8-10 for calculating length-to-diameter ratio
 Factory technical assistance is available for your specific applications through our Application Engineering department. *email: engineering.eu@alliedmachine.com*

DIN 2080 Master Shanks

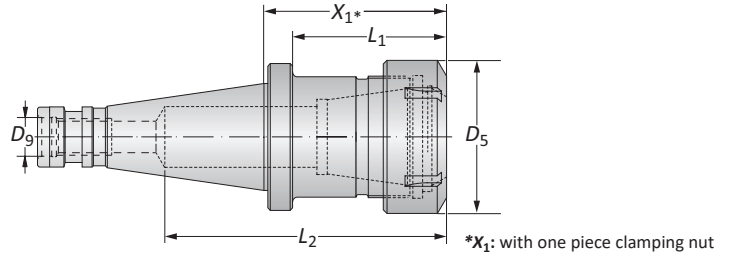
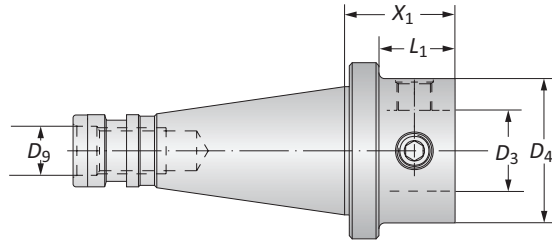

Taper Size	Connection	Shank					Weight	Part No.	
	$D_4 D_3$	X_1	L_1	L_2	D_5	D_9			
m	40	50 - 28	38.00	26.40	-	-	M16 x 2	1.30 (kg)	132022T010229
	40	63 - 36	48.00	36.40	-	-	M16 x 2	1.50 (kg)	132066T010229
	50	50 - 28	42.00	26.80	-	-	M24 x 3	3.00 (kg)	132022T003704
	50	63 - 36	52.00	36.80	-	-	M24 x 3	3.50 (kg)	132066T003704
	50	80 - 36	52.00	36.80	-	-	M24 x 3	4.00 (kg)	132088T003704
	50	100 - 56	90.00	74.80	-	-	M24 x 3	4.90 (kg)	132076T003704
	50	ER 40	80.00	64.80	134.00	63.00	M24 x 3	3.30 (kg)	259084

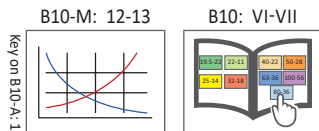

m = Metric (mm)

WARNING Exceeding weight capacity for machine tool spindle and tool changer can cause machine damage and/or serious injury. To prevent:
 -Consult machine tool builder for machine's weight limitations.
 -Refer to example on page B10-M: 11 for calculating tool assembly weight
 Factory technical assistance is also available for specific applications through our Application Engineering department. email: engineering.eu@alliedmachine.com

WARNING Tool failure can cause serious injury. To prevent:
 -Do not exceed recommended 10xD length-to-diameter ratio or exceed 4 total components (including shank)
 -When using Alu-Line® components, do not exceed recommended 5xD length-to-diameter ratio
 -When using tool steel components, do not exceed recommended 6xD length-to-diameter ratio
 -When using heavy metal reducers, do not exceed recommended 8xD length-to-diameter ratio
 -When using a carbide shank, do not exceed recommended 9xD length-to-diameter ratio
 -When using a NOVITECH® module, do not exceed recommended 10xD length-to-diameter ratio
 -Refer to examples on pages B10-M: 8-10 for calculating length-to-diameter ratio
 Factory technical assistance is available for your specific applications through our Application Engineering department. email: engineering.eu@alliedmachine.com

DIN 1806 Morse Taper Master Shanks | R8 Master Shanks

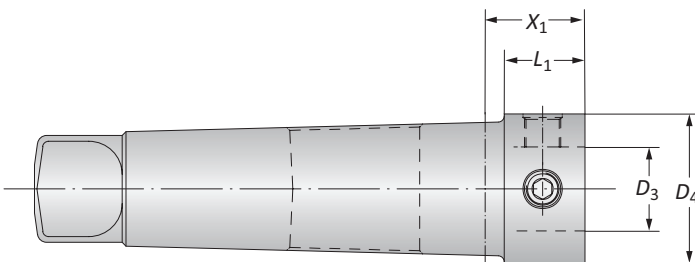

DIN 1806 Master Shanks

Morse Taper Size	Connection $D_4 D_3$	Shank		Weight	Part No.
		X_1	L_1		
4	50 - 28	43.00	36.50	1.10 (kg)	132022T003590
5	50 - 28	33.00	26.70	1.80 (kg)	132022T003920
5	63 - 36	53.00	46.70	2.20 (kg)	132066T003920

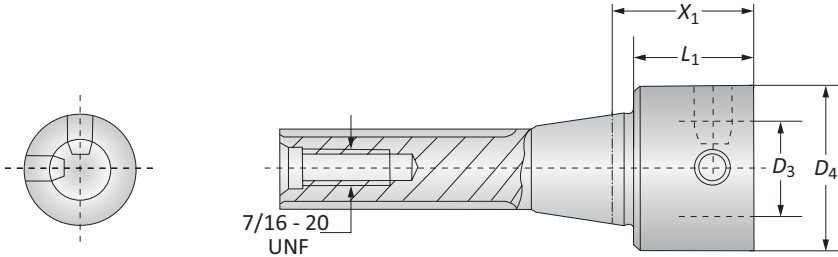

Connection $D_4 D_3$	Shank		Weight	Part No.
	X_1	L_1		
50 - 28	45.00	36.00	1.00 (kg)	132022T007166
63 - 36	60.00	51.00	1.30 (kg)	132066T007166

B10-M: 12-13

B10: VI-VII

Key on B10-F: 1

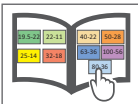
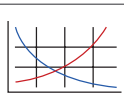

m = Metric (mm)

WARNING Exceeding weight capacity for machine tool spindle and tool changer can cause machine damage and/or serious injury. To prevent:

- Consult machine tool builder for machine's weight limitations.
- Refer to example on page B10-M: 11 for calculating tool assembly weight
- Factory technical assistance is also available for specific applications through our Application Engineering department. *email: engineering.eu@alliedmachine.com*

WARNING Tool failure can cause serious injury. To prevent:

- Do not exceed recommended 10xD length-to-diameter ratio or exceed 4 total components (including shank)
- When using Alu-Line® components, do not exceed recommended 5xD length-to-diameter ratio
- When using tool steel components, do not exceed recommended 6xD length-to-diameter ratio
- When using heavy metal reducers, do not exceed recommended 8xD length-to-diameter ratio
- When using a carbide shank, do not exceed recommended 9xD length-to-diameter ratio
- When using a NOVI^{TECH}® module, do not exceed recommended 10xD length-to-diameter ratio
- Refer to examples on pages B10-M: 8-10 for calculating length-to-diameter ratio
- Factory technical assistance is available for your specific applications through our Application Engineering department. *email: engineering.eu@alliedmachine.com*

Accessories

Coolant Adapter Sets | Service Keys | ISO 15488 (DIN 6499-B) Collet Chuck Accessories

Coolant Adapter Sets

HSK Shank Size	Thread	Part No.
32	M10 x 1.5 x 1.0	262002
40	M12 x 1.75 x 1.0	262003
50	M16 x 2 x 1.0	262004
63	M18 x 2.5 x 1.0	262005
80	M20 x 2.5 x 1.5	262006
100	M24 x 3 x 1.5	262007

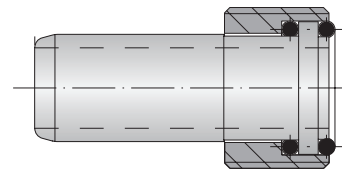

Service Keys

HSK Shank Size	D	Part No.
32	8.50	315234
40	10.50	315235
50	14.50	215726
63	16.50	215727*
80	18.00	415127
100	22.00	215728

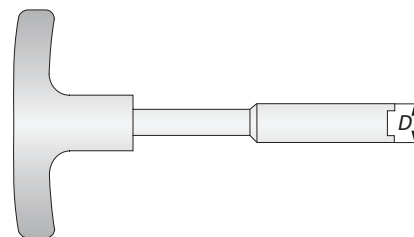

*Two piece

ISO 15488 (DIN 6499-B) One Piece Clamping Nut

Nominal Size	Clamping Nut		Part No.
	L ₁	D ₁	
ER 40	25.50	63.00	215926

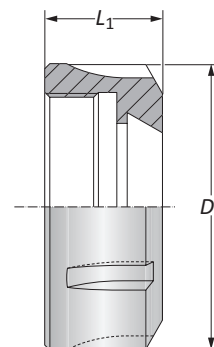

ISO 15488 (DIN 6499-B) Sealing Disk Clamping Nut

Nominal Size	Sealing Disk Clamping Nut		Part No.
	L ₁	D ₁	
ER 40	34.00	63.00	278001

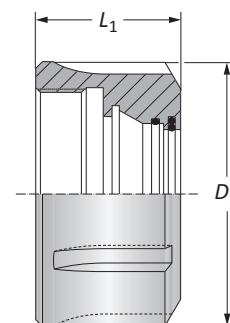

B10-M: 12-13

B10: VI-VII

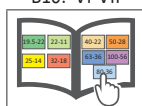
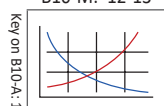

m = Metric (mm)

Accessories

ISO 15488 (DIN 6499-B) Collet Chuck Accessories

ISO 15488 (DIN6499-B) Collets

	Clamping Range		Collet		Part No.
	A	L_1	D_1		
m	15.00 - 14.00	46.00	40.00		071790
	18.00 - 17.00	46.00	40.00		071793
	20.00 - 19.00	46.00	40.00		071795
	23.00 - 22.00	46.00	40.00		071798

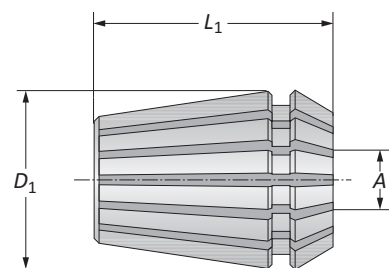

ISO 15488 (DIN 6499-B) Service Keys

	Service Key		Part No.
	Nominal Size	D	
m	ER 40	63.00	215931

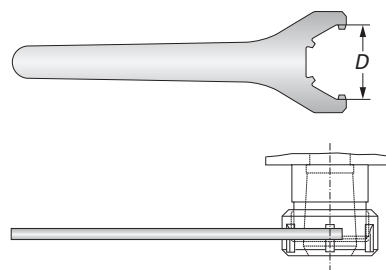

ISO 15488 (DIN 6499-B) Sealing Disks

	Clamping Range		Part No.
	A	D_1	
m	15.00 - 14.50		278029
	18.00 - 17.50		278035
	20.00 - 19.50		278039
	23.00 - 22.50		278045

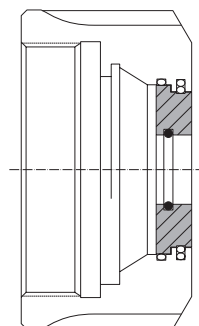

Application with clamping nuts and sealing disks when using central coolant feed:

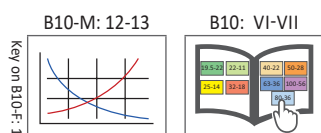
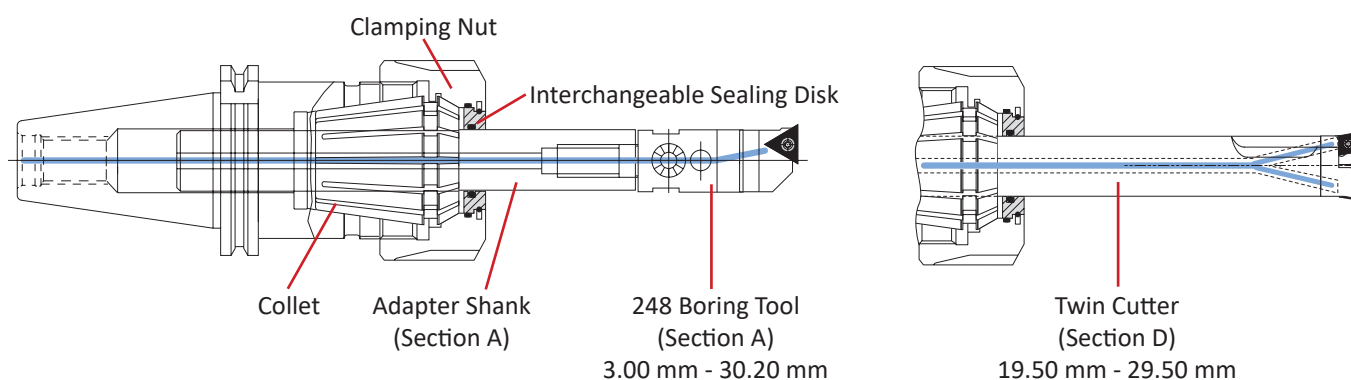

m = Metric (mm)

Accessories

Mounting Fixtures



Mounting Fixture		
Code	Type	Part No.
Basic Body*	-	098060
Adapter	30 Taper	098073
Adapter	40 Taper	098061
Adapter	50 Taper	098062
Adapter	HSK-A 32	098063
Adapter	HSK-A 40	098064
Adapter	HSK-A 50	098065
Adapter	HSK-A 63	098066
Adapter	HSK-A 80	098067
Adapter	HSK-A 100	098068
Adapter	PSC 50	098069
Adapter	PSC 63	098070
Adapter	PSC 80	098071

*Basic body and adapters sold separately

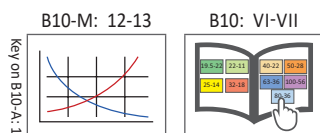

Ⓜ = Metric (mm)

⚠ WARNING Exceeding weight capacity for machine tool spindle and tool changer can cause machine damage and/or serious injury. To prevent:
 -Consult machine tool builder for machine's weight limitations.
 -Refer to example on page B10-M: 11 for calculating tool assembly weight
 Factory technical assistance is also available for specific applications through our Application Engineering department. *email: engineering.eu@alliedmachine.com*

⚠ WARNING Tool failure can cause serious injury. To prevent:
 -Do not exceed recommended 10xD length-to-diameter ratio or exceed 4 total components (including shank)
 -When using Alu-Line® components, do not exceed recommended 5xD length-to-diameter ratio
 -When using tool steel components, do not exceed recommended 6xD length-to-diameter ratio
 -When using heavy metal reducers, do not exceed recommended 8xD length-to-diameter ratio
 -When using a carbide shank, do not exceed recommended 9xD length-to-diameter ratio
 -When using a NOVITECH® module, do not exceed recommended 10xD length-to-diameter ratio
 -Refer to examples on pages B10-M: 8-10 for calculating length-to-diameter ratio
 Factory technical assistance is available for your specific applications through our Application Engineering department. *email: engineering.eu@alliedmachine.com*

SECTION

B10-G

Large Diameter Boring

Wohlhaupter® Large Diameter Boring

Basic D 40 | Basic D 60 | Eco D 60 | Flex D 60

▶ Diameter Range: 200.00 mm - 3255.00 mm

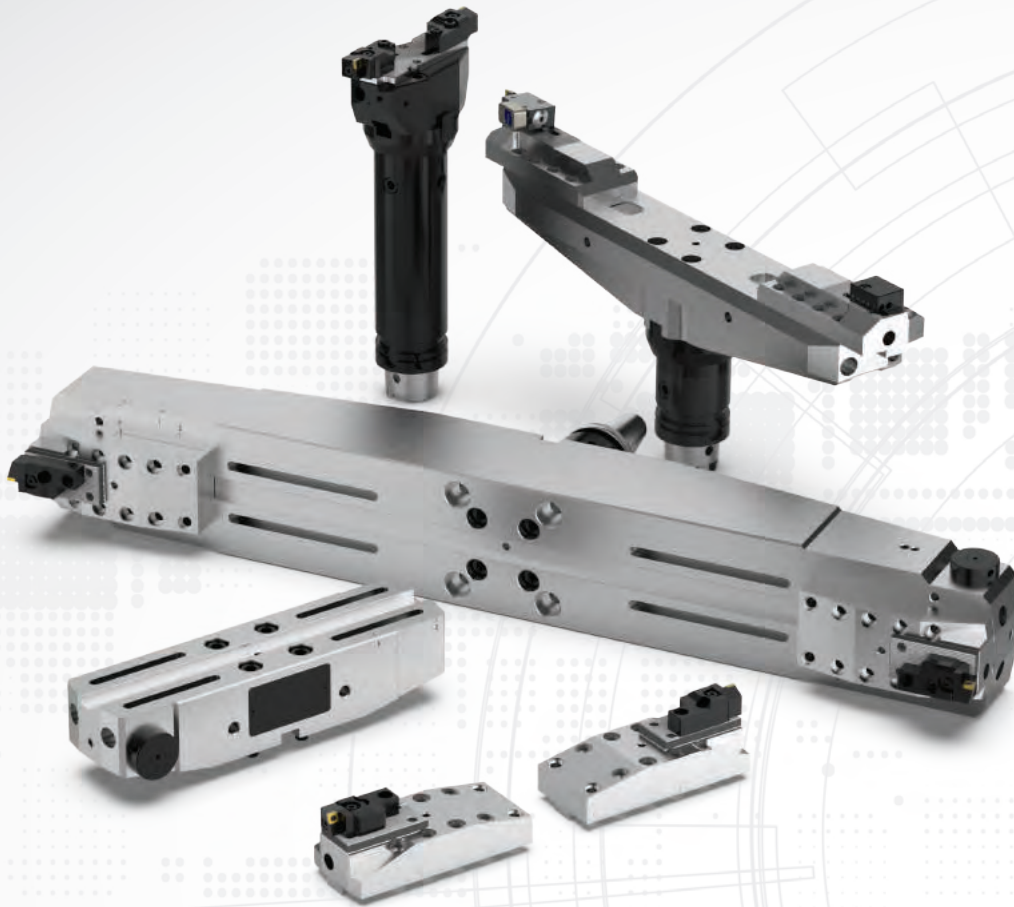

Boring Big?

Wohlhaupter has continued to expand our large diameter boring capabilities with Alu-Line. Our Alu-Line serrated slides and tool bodies are made of lightweight aluminium alloy to minimise the weight while still getting the heavy boring job done. The versatile serrated slides and serrated tool bodies allow for boring 200.00 mm up to 3255.00 mm, offering the most powerful and versatile tool ranges to our customers.

Your safety and the safety of others is very important. This catalogue contains important safety messages. Always read and follow all safety precautions.



This triangle is a safety hazard symbol. It alerts you to potential safety hazards that can cause tool failure and serious injury.

When you see this symbol in the catalogue, look for a related safety message that may be near this triangle or referred to in the nearby text.

There are safety signal words also used in the catalogue. Safety messages follow these words.

⚠ WARNING

WARNING (shown above) means that failure to follow the precautions in this message could result in tool failure and serious injury.

NOTICE means that failure to follow the precautions in this message could result in damage to the tool or machine but not result in personal injury.

NOTE and **IMPORTANT** are also used. These are important that you read and follow but are not safety-related.

Visit www.alliedmachine.com for the most up-to-date information and procedures.

Applicable Industries



Aerospace



Agriculture



Automotive



Firearms



General
Machining



Oil & Gas



Renewable
Energy

Large Diameter Boring Table of Contents

Reference Icons

The following icons will appear throughout the catalogue to help you navigate between products.

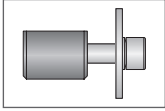

Clamping Elements

For use with insert holders and boring heads

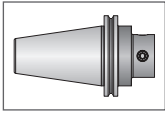

Shanks

A variety of shanks for different machines

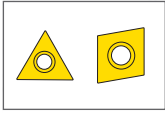

Inserts

For use with insert holder boring heads and boring bars using indexable inserts

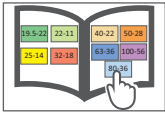

MVS Connection Colour Guide

Detailed instructions and information regarding the MVS connection(s)

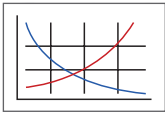

Recommended Cutting Data

Speed and feed recommendations for optimum and safe boring



Through Coolant Option

Indicates that the product is through coolant

Introduction

Product Overview 2 - 3

Serrated Slides

Alu-Line Basic D 40 Serrated Slides 4
 Alu-Line Basic D 60 Serrated Slides 5
 Alu-Line Eco D 60 Serrated Slides 6
 Alu-Line Flex D 60 Serrated Slides 7

Serrated Adapter with MVS Connection 8 - 9

537 Boring Cassettes

537 Analogue Cassettes 10
 537 Digital Cassettes with 3E^{TECH} 11

Insert Holders

Insert Holders for Rough Machining 12 - 13
 Insert Holders for Height Adjustments and Axial Grooving 14

Holding Arbors and Shanks

MVS Holding Arbors D40/D60 15
 Master Shanks D40/D60 16 - 19

Accessories 20 - 25

Series	Diameter Range
	Metric (mm)
Basic D 40 Slides	200.00 - 520.00
Basic D 60 Slides	200.00 - 505.00
Eco D 60 Slides	465.00 - 1020.00
Flex D 60 Slides	500.00 - 3255.00

Large Diameter Boring

Large Diameter BORING

Boring big? We've got you covered.

Our versatile tooling system can provide the power and precision your large diameter boring jobs demand. The large diameter boring system offers four different Alu-Line serrated slides, a wide range of rough and finish boring insert holders, vernier and digital cassettes, and combined rough and finish insert holders.

- Diameter range: 200.00 mm - 3255.00 mm
- Basic, Eco, and Flex serrated slides
- Roughing, finishing, or combined roughing and finishing can be achieved in one pass
- Digital readout cassettes available for quick and easy adjustments
- Alu-Line serrated slides and tool bodies are made of lightweight aluminium

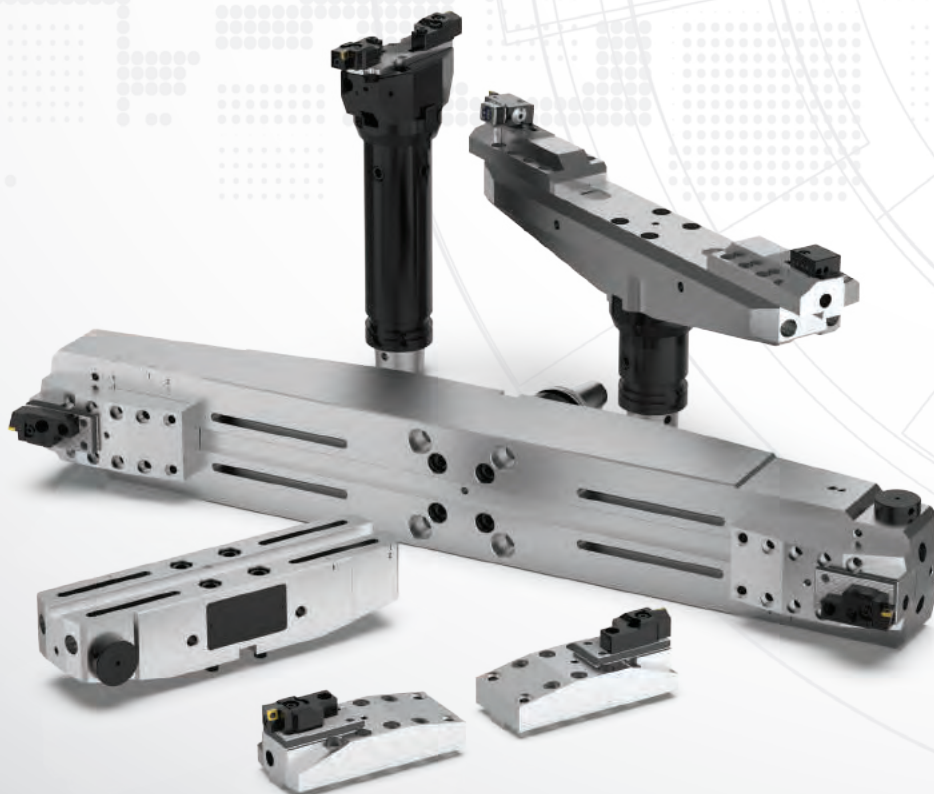

► **Basic D 40 Serrated Slides for Finish Boring**



► **Basic D 60 Serrated Slides for Rough and Finish Boring**

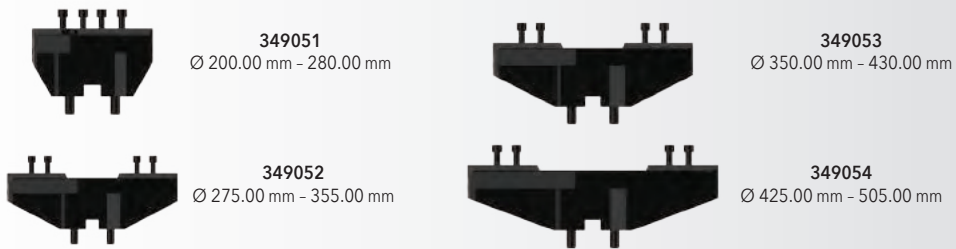

► **Eco D 60 Serrated Slides for Rough and Finish Boring**

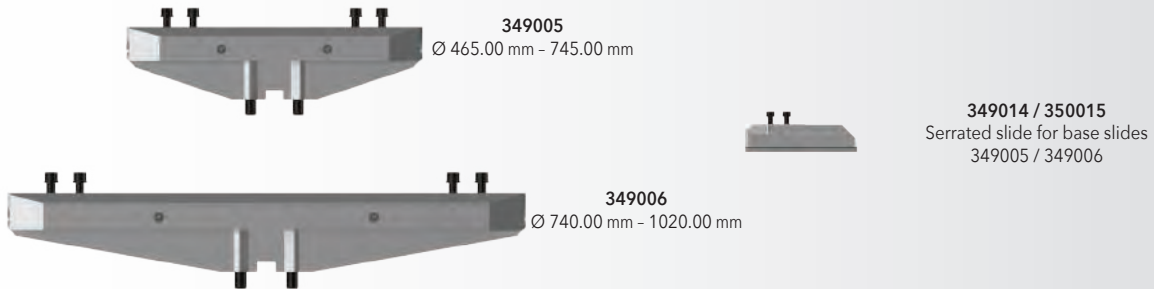

► **Flex D 60 Serrated Slides for Rough and Finish Boring**

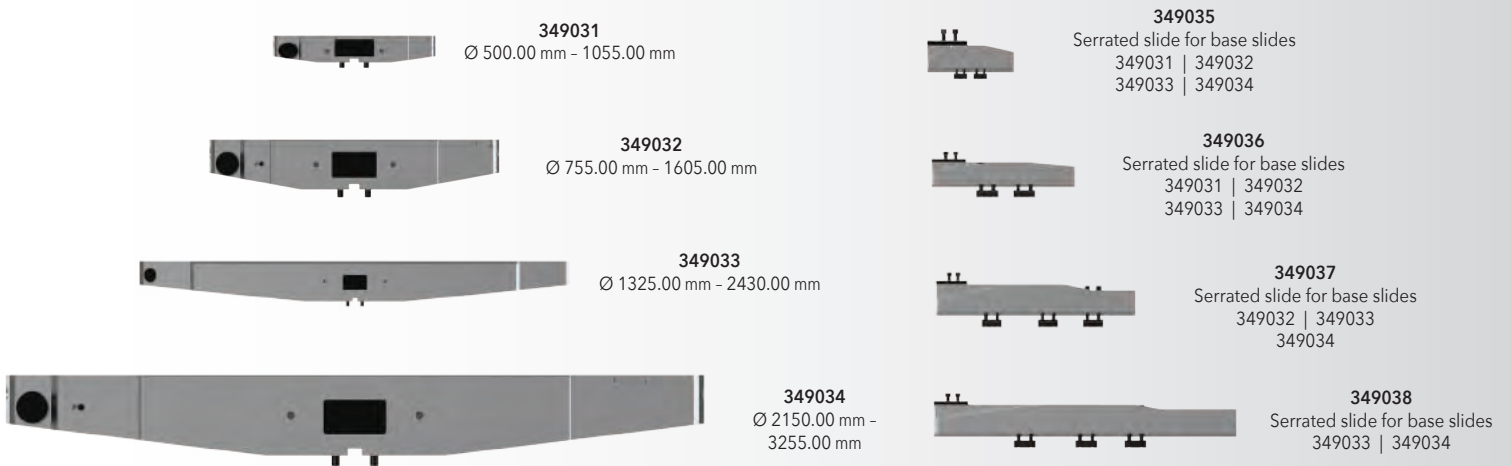

Alu-Line Basic D 40 Serrated Slides

Diameter Range: 200.00 mm - 520.00 mm

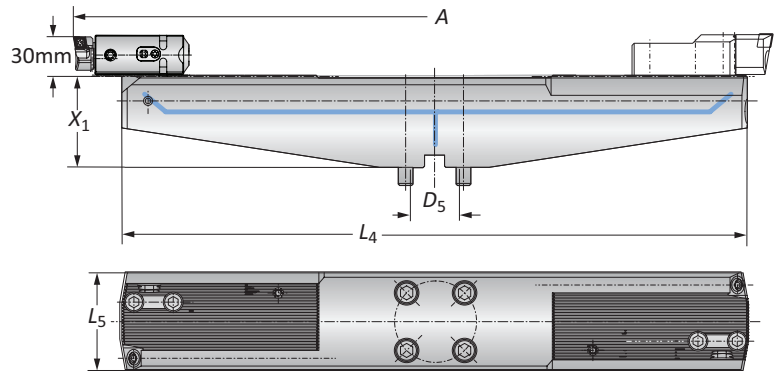

	Connection	Boring Range	Serrated Slide			Weight	Part No.
	D_5	A	X_1	L_4	L_5		
Ⓜ	D 40	200.00 - 280.00	75.00	190.00	80.00	2.80 (kg)	349021
	D 40	280.00 - 360.00	75.00	270.00	80.00	3.80 (kg)	349022
	D 40	360.00 - 440.00	75.00	350.00	80.00	5.00 (kg)	349023
	D 40	440.00 - 520.00	75.00	430.00	80.00	6.00 (kg)	349024

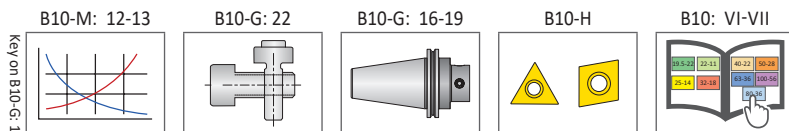

Ⓜ = Metric (mm)

⚠ WARNING Exceeding weight capacity for machine tool spindle and tool changer can cause machine damage and/or serious injury. To prevent:
 -Consult machine tool builder for machine's weight limitations.
 -Refer to example on page B10-M: 11 for calculating tool assembly weight
 Factory technical assistance is also available for specific applications through our Application Engineering department. *email: engineering.eu@alliedmachine.com*

⚠ WARNING Tool failure can cause serious injury. To prevent:
 -Do not exceed recommended 10xD length-to-diameter ratio or exceed 4 total components (including shank)
 -When using Alu-Line® components, do not exceed recommended 5xD length-to-diameter ratio
 -When using tool steel components, do not exceed recommended 6xD length-to-diameter ratio
 -When using heavy metal components, do not exceed recommended 8xD length-to-diameter ratio
 -When using a carbide shank, do not exceed recommended 9xD length-to-diameter ratio
 -When using a NOVITECH module, do not exceed recommended 10xD length-to-diameter ratio
 -Refer to examples on pages B10-M: 8-10 for calculating length-to-diameter ratio
 Factory technical assistance is available for your specific applications through our Application Engineering department. *email: engineering.eu@alliedmachine.com*



Alu-Line Basic D 60 Serrated Slides

Diameter Range: 200.00 mm - 505.00 mm

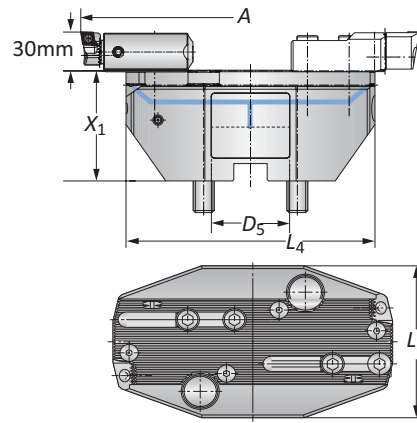

	Connection	Boring Range	Serrated Slide			Weight	Part No.
	D_5	A	X_1	L_4	L_5		
Ⓜ	D 60	200.00 - 280.00	85.00	191.00	110.00	4.10 (kg)	349051
	D 60	275.00 - 355.00	85.00	264.00	110.00	5.20 (kg)	349052
	D 60	350.00 - 430.00	85.00	339.00	125.00	6.90 (kg)	349053
	D 60	425.00 - 505.00	85.00	414.00	125.00	8.00 (kg)	349054

A
B
C
D
E
F
G
H
I
J
K
L
M
INDEX

Key on B10-G: 1

B10-M: 12-13

B10-G: 23

B10-G: 16-19

B10-H

B10: VI-VII

Ⓜ = Metric (mm)

⚠ WARNING Exceeding weight capacity for machine tool spindle and tool changer can cause machine damage and/or serious injury. To prevent:
 -Consult machine tool builder for machine's weight limitations.
 -Refer to example on page B10-M: 11 for calculating tool assembly weight
 Factory technical assistance is also available for specific applications through our Application Engineering department. *email: engineering.eu@alliedmachine.com*

⚠ WARNING Tool failure can cause serious injury. To prevent:
 -Do not exceed recommended 10xD length-to-diameter ratio or exceed 4 total components (including shank)
 -When using Alu-Line® components, do not exceed recommended 5xD length-to-diameter ratio
 -When using tool steel components, do not exceed recommended 6xD length-to-diameter ratio
 -When using heavy metal components, do not exceed recommended 8xD length-to-diameter ratio
 -When using a carbide shank, do not exceed recommended 9xD length-to-diameter ratio
 -When using a NOVITECH module, do not exceed recommended 10xD length-to-diameter ratio
 -Refer to examples on pages B10-M: 8-10 for calculating length-to-diameter ratio
 Factory technical assistance is available for your specific applications through our Application Engineering department. *email: engineering.eu@alliedmachine.com*

Alu-Line Eco D 60 Serrated Slides

Diameter Range: 465.00 mm - 1020.00 mm

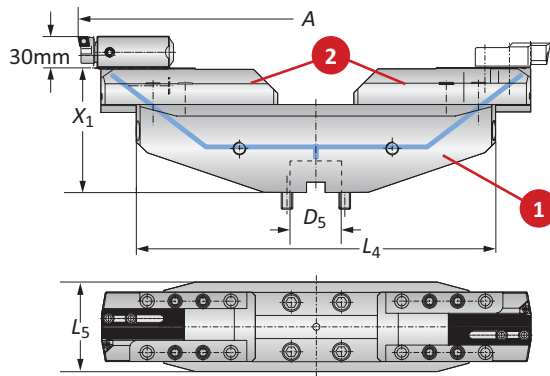

Connection	Boring Range	Serrated Slide			1 Base Slide		2 Serrated Slide (Alu-Line)*		2 Serrated Slide (steel)**		
		D_5	A	X_1	L_4	L_5	Weight	Part No.	Weight	Part No.	Weight
M	D 60	465.00 - 745.00	155.00	447.00	129.00	11.80 (kg)	349005	2.20 (kg)	349015	5.70 (kg)	349014
	D 60	740.00 - 1020.00	155.00	722.00	129.00	18.00 (kg)	349006	2.20 (kg)	349015	5.70 (kg)	349014

*Finish boring: serrated slide in Alu-Line

**Rough boring: serrated slide in steel

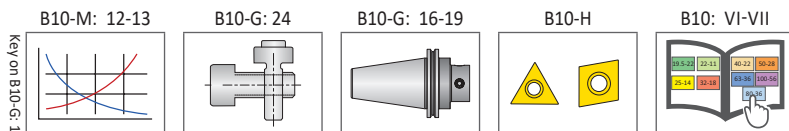

M = Metric (mm)

WARNING Exceeding weight capacity for machine tool spindle and tool changer can cause machine damage and/or serious injury. To prevent:
 -Consult machine tool builder for machine's weight limitations.
 -Refer to example on page B10-M: 11 for calculating tool assembly weight
 Factory technical assistance is also available for specific applications through our Application Engineering department. *email: engineering.eu@alliedmachine.com*

WARNING Tool failure can cause serious injury. To prevent:
 -Do not exceed recommended 10xD length-to-diameter ratio or exceed 4 total components (including shank)
 -When using Alu-Line® components, do not exceed recommended 5xD length-to-diameter ratio
 -When using tool steel components, do not exceed recommended 6xD length-to-diameter ratio
 -When using heavy metal components, do not exceed recommended 8xD length-to-diameter ratio
 -When using a carbide shank, do not exceed recommended 9xD length-to-diameter ratio
 -When using a NOVITECH module, do not exceed recommended 10xD length-to-diameter ratio
 -Refer to examples on pages B10-M: 8-10 for calculating length-to-diameter ratio
 Factory technical assistance is available for your specific applications through our Application Engineering department. *email: engineering.eu@alliedmachine.com*



Alu-Line Flex D 60 Serrated Slides

Diameter Range: 500.00 mm - 3255.00 mm

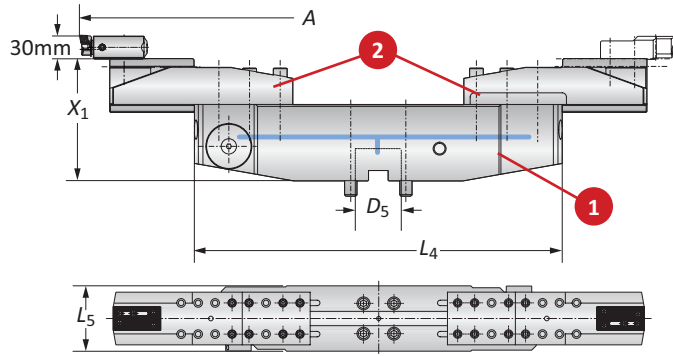

Connection	Boring Range	Serrated Slide			Weight (1 + 2)	Part No.		
		D_5	A	X_1		L_4	L_5	1 Base Slide
m	D 60	500.00 - 780.00	160.00	480.00	130.00	24.20 (kg)	349031	349035
	D 60	950.00 - 1055.00	185.00	480.00	130.00	41.30 (kg)	349031	349036
	D 60	775.00 - 1055.00	185.00	755.00	155.00	42.50 (kg)	349032	349035
	D 60	1050.00 - 1330.00	210.00	755.00	155.00	59.60 (kg)	349032	349036
	D 60	1442.00 - 1605.00	225.00	755.00	155.00	86.30 (kg)	349032	349037
	D 60	1325.00 - 1605.00	210.00	1305.00	185.00	88.20 (kg)	349033	349035
	D 60	1325.00 - 1880.00	235.00	1305.00	185.00	105.30 (kg)	349033	349036
	D 60	1600.00 - 2155.00	250.00	1305.00	185.00	132.00 (kg)	349033	349037
	D 60	1990.00 - 2430.00	255.00	1305.00	185.00	169.80 (kg)	349033	349038
	D 60	2150.00 - 2430.00	235.00	2130.00	225.00	192.50 (kg)	349034	349035
	D 60	2150.00 - 2705.00	260.00	2130.00	225.00	209.60 (kg)	349034	349036
	D 60	2150.00 - 2980.00	275.00	2130.00	225.00	236.00 (kg)	349034	349037
	D 60	2150.00 - 3255.00	280.00	2130.00	225.00	274.00 (kg)	349034	349038

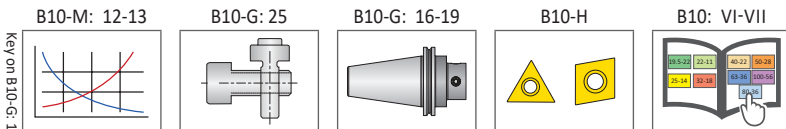

m = Metric (mm)

WARNING Exceeding weight capacity for machine tool spindle and tool changer can cause machine damage and/or serious injury. To prevent:
 -Consult machine tool builder for machine's weight limitations.
 -Refer to example on page B10-M: 11 for calculating tool assembly weight
 Factory technical assistance is also available for specific applications through our Application Engineering department. *email: engineering.eu@alliedmachine.com*

WARNING Tool failure can cause serious injury. To prevent:
 -Do not exceed recommended 10xD length-to-diameter ratio or exceed 4 total components (including shank)
 -When using Alu-Line® components, do not exceed recommended 5xD length-to-diameter ratio
 -When using tool steel components, do not exceed recommended 6xD length-to-diameter ratio
 -When using heavy metal components, do not exceed recommended 8xD length-to-diameter ratio
 -When using a carbide shank, do not exceed recommended 9xD length-to-diameter ratio
 -When using a NOVITECH module, do not exceed recommended 10xD length-to-diameter ratio
 -Refer to examples on pages B10-M: 8-10 for calculating length-to-diameter ratio
 Factory technical assistance is available for your specific applications through our Application Engineering department. *email: engineering.eu@alliedmachine.com*

Serrated Adapter with MVS Connection

Mounting Adapter

MVS Connection	Mounting Adapters				Weight	Part No.
	D_2 D_1	X_1	X_2	L_1		
M 50 - 28	50.00	27.00	101.00	76.00	1.30 (kg)	349046

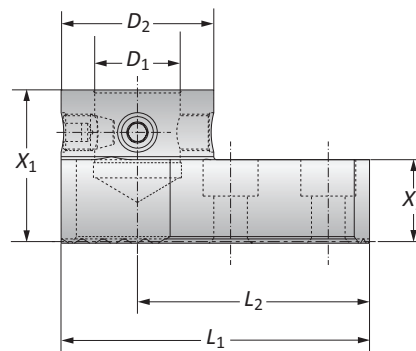

Inside Boring

Slide	Boring Heads	ID Bore Range mm
349051	310005/464006/564045	215.00 - 313.00
349052	310005/464006/564045	290.00 - 388.00
349053	310005/464006/564045	365.00 - 463.00
349054	310005/464006/564045	440.00 - 538.00
349005 with 349015	310005/464006/564045	480.00 - 778.00

Outside Boring

Slide	Boring Heads	OD Bore Range mm
349051	310005/464006/565045	67.00 - 165.00
349052	310005/464006/565045	142.00 - 240.00
349053	310005/464006/565045	217.00 - 315.00
349054	310005/464006/565045	292.00 - 390.00
349005 with 349015	310005/464006/565045	332.00 - 630.00

NOTE: LH only spindle rotation

B10-M: 12-13

B10: VI-VII

Key on B10-G: 1

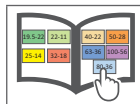
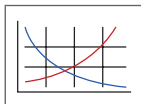

M = Metric (mm)

WARNING Exceeding weight capacity for machine tool spindle and tool changer can cause machine damage and/or serious injury. To prevent:

- Consult machine tool builder for machine's weight limitations.
- Refer to example on page B10-M: 11 for calculating tool assembly weight
- Factory technical assistance is also available for specific applications through our Application Engineering department. *email: engineering.eu@alliedmachine.com*

WARNING Tool failure can cause serious injury. To prevent:

- Do not exceed recommended 10xD length-to-diameter ratio or exceed 4 total components (including shank)
- When using Alu-Line® components, do not exceed recommended 5xD length-to-diameter ratio
- When using tool steel components, do not exceed recommended 6xD length-to-diameter ratio
- When using heavy metal components, do not exceed recommended 8xD length-to-diameter ratio
- When using a carbide shank, do not exceed recommended 9xD length-to-diameter ratio
- When using a NOVITECH module, do not exceed recommended 10xD length-to-diameter ratio
- Refer to examples on pages B10-M: 8-10 for calculating length-to-diameter ratio
- Factory technical assistance is available for your specific applications through our Application Engineering department. *email: engineering.eu@alliedmachine.com*



Serrated Adapter with MVS Connection

Mounting Adapter

MVS Connection	Mounting Adapters				Weight	Part No.
	D ₂ D ₁	X ₁	X ₂	L ₁		
50 - 28	50.00	27.00	101.00	76.00	1.30 (kg)	349046

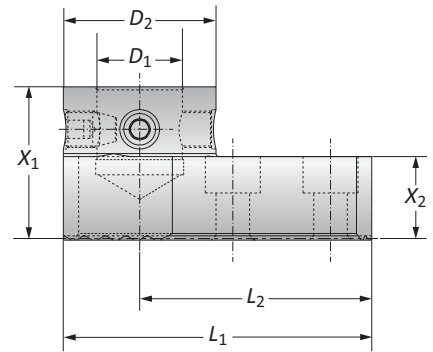

Inside Boring

Slide	Boring Heads	ID Bore Range mm
349051	310005/464006/564045	65.00 - 128.00
349052	310005/464006/564045	105.00 - 203.00
349053	310005/464006/564045	180.00 - 278.00
349054	310005/464006/564045	255.00 - 353.00
349005 with 349015	310005/464006/564045	295.00 - 593.00

Outside Boring

Slide	Boring Heads	OD Bore Range mm
349051	310005/464006/564045	-
349052	310005/464006/564045	0.00 - 55.00
349053	310005/464006/564045	32.00 - 130.00
349054	310005/464006/564045	107.00 - 205.00
349005 with 349015	310005/464006/564045	147.00 - 445.00

NOTE: LH only spindle rotation

B10-M: 12-13

B10: VI-VII

Key on B10-G: 1

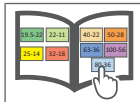
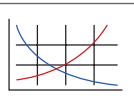

= Metric (mm)

WARNING Exceeding weight capacity for machine tool spindle and tool changer can cause machine damage and/or serious injury. To prevent:

-Consult machine tool builder for machine's weight limitations.

-Refer to example on page B10-M: 11 for calculating tool assembly weight

Factory technical assistance is also available for specific applications through our Application Engineering department. *email: engineering.eu@alliedmachine.com*

WARNING Tool failure can cause serious injury. To prevent:

-Do not exceed recommended 10xD length-to-diameter ratio or exceed 4 total components (including shank)

-When using Alu-Line® components, do not exceed recommended 5xD length-to-diameter ratio

-When using tool steel components, do not exceed recommended 6xD length-to-diameter ratio

-When using heavy metal components, do not exceed recommended 8xD length-to-diameter ratio

-When using a carbide shank, do not exceed recommended 9xD length-to-diameter ratio

-When using a NOVITECH® module, do not exceed recommended 10xD length-to-diameter ratio

-Refer to examples on pages B10-M: 8-10 for calculating length-to-diameter ratio

Factory technical assistance is available for your specific applications through our Application Engineering department. *email: engineering.eu@alliedmachine.com*

537 Analogue Cassettes

Diameter Range: 100.00 mm - 3255.00 mm



Form 101

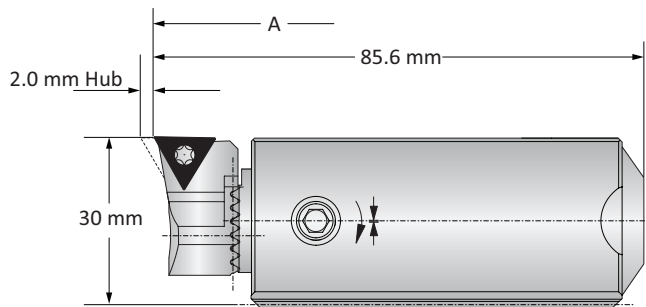

Form 20

Slide Type	Boring Range		Insert Form	Part No.		
	A	Weight		Insert Holder	Clamping Piece	Cassette
Serrated Tool Bodies	100.00 - 205.00	0.60 (kg)	20	210020	137026	537051
	100.00 - 205.00	0.60 (kg)	101	210063	137026	537051
	100.00 - 205.00	0.60 (kg)	103	210064	137026	537051
Basic / Eco Slides	200.00 - 1020.00	0.60 (kg)	20	210020	137027	537051
	200.00 - 1020.00	0.60 (kg)	101	210063	137027	537051
	200.00 - 1020.00	0.60 (kg)	103	210064	137027	537051
Flex Slides	500.00 - 3255.00	0.60 (kg)	20	210020	137019	537051
	500.00 - 3255.00	0.60 (kg)	101	210063	137019	537051
	500.00 - 3255.00	0.60 (kg)	103	210064	137019	537051

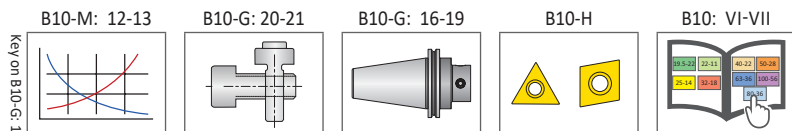

m = Metric (mm)

Inserts sold separately

WARNING Exceeding weight capacity for machine tool spindle and tool changer can cause machine damage and/or serious injury. To prevent:
 -Consult machine tool builder for machine's weight limitations.
 -Refer to example on page B10-M: 11 for calculating tool assembly weight
 Factory technical assistance is also available for specific applications through our Application Engineering department. *email: engineering.eu@alliedmachine.com*

WARNING Tool failure can cause serious injury. To prevent:
 -Do not exceed recommended 10xD length-to-diameter ratio or exceed 4 total components (including shank)
 -When using Alu-Line® components, do not exceed recommended 5xD length-to-diameter ratio
 -When using tool steel components, do not exceed recommended 6xD length-to-diameter ratio
 -When using heavy metal components, do not exceed recommended 8xD length-to-diameter ratio
 -When using a carbide shank, do not exceed recommended 9xD length-to-diameter ratio
 -When using a NOVITECH module, do not exceed recommended 10xD length-to-diameter ratio
 -Refer to examples on pages B10-M: 8-10 for calculating length-to-diameter ratio
 Factory technical assistance is available for your specific applications through our Application Engineering department. *email: engineering.eu@alliedmachine.com*



537 Digital Cassettes with 3E^{TECH+}

Diameter Range: 100.00 mm - 3255.00 mm



Form 101

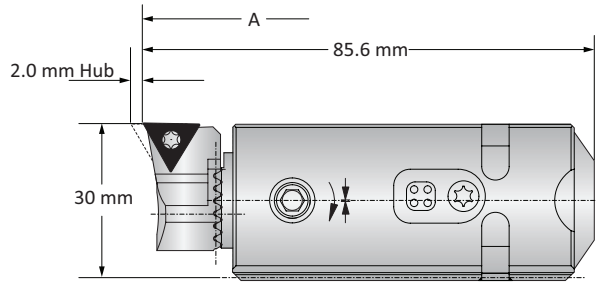

Form 20

Slide Type	Boring Range		Insert Form	Part No.		
	A	Weight		Insert Holder	Clamping Pieces	Cassette
Serrated Tool Bodies	100.00 - 205.00	0.60 (kg)	20	210020	137026	537052
	100.00 - 205.00	0.60 (kg)	101	210063	137026	537052
	100.00 - 205.00	0.60 (kg)	103	210064	137026	537052
Basic / Eco Slides	200.00 - 1020.00	0.60 (kg)	20	210020	137027	537052
	200.00 - 1020.00	0.60 (kg)	101	210063	137027	537052
	200.00 - 1020.00	0.60 (kg)	103	210064	137027	537052
Flex Slides	500.00 - 3255.00	0.60 (kg)	20	210020	137019	537052
	500.00 - 3255.00	0.60 (kg)	101	210063	137019	537052
	500.00 - 3255.00	0.60 (kg)	103	210064	137019	537052

3E^{TECH+} Digital Readout Module

Part No.	Charging Unit*
536015	536016

NOTE: WEEE-Reg.-Nr. DE 15820388

*Charging unit sold separately



NOTE: 3E^{TECH+} adjustment accuracy of 0.001 mm on diameter

Key on B10-G-1

B10-M: 12-13 	B10-G: 20-21 	B10-G: 16-19 	B10-H 	B10: VI-VII
------------------	------------------	------------------	-----------	-----------------

Ⓜ = Metric (mm)
Inserts sold separately

⚠ WARNING Exceeding weight capacity for machine tool spindle and tool changer can cause machine damage and/or serious injury. To prevent:
 -Consult machine tool builder for machine's weight limitations.
 -Refer to example on page B10-M: 11 for calculating tool assembly weight
 Factory technical assistance is also available for specific applications through our Application Engineering department. *email: engineering.eu@alliedmachine.com*

⚠ WARNING Tool failure can cause serious injury. To prevent:
 -Do not exceed recommended 10xD length-to-diameter ratio or exceed 4 total components (including shank)
 -When using Alu-Line® components, do not exceed recommended 5xD length-to-diameter ratio
 -When using tool steel components, do not exceed recommended 6xD length-to-diameter ratio
 -When using heavy metal components, do not exceed recommended 8xD length-to-diameter ratio
 -When using a carbide shank, do not exceed recommended 9xD length-to-diameter ratio
 -When using a NOVITECH module, do not exceed recommended 10xD length-to-diameter ratio
 -Refer to examples on pages B10-M: 8-10 for calculating length-to-diameter ratio
 Factory technical assistance is available for your specific applications through our Application Engineering department. *email: engineering.eu@alliedmachine.com*

Insert Holders for Rough Machining

90° Insert Holders

Insert Holder		Weight	ISO Code	Insert Form	Part No.
K	X ₁				
90°	30.00	0.60 (kg)	CC..09T3..	103	149090
90°	30.00	0.60 (kg)	CC..1204..	104	149099
90°	29.30	0.60 (kg)	CC..1204..	104	149083
90°	30.00	0.60 (kg)	CC..1605..	105	149093

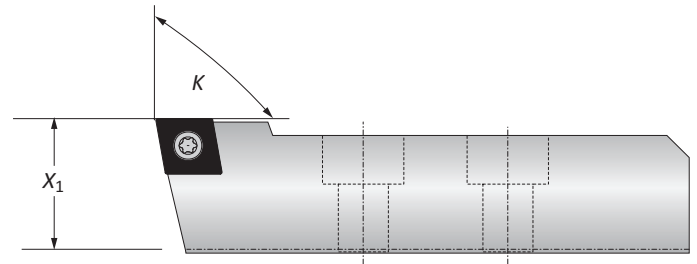

90° Tangential Insert Holders

Insert Holder		Weight	ISO Code	Insert Form	Part No.
K	X ₁				
90°	30.00	0.60 (kg)	Tangential	05	149010
90°	29.30	0.60 (kg)	Tangential	05	149020

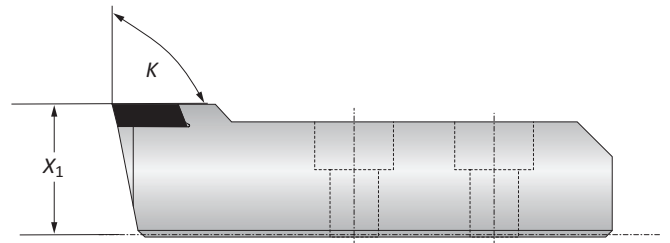

80° Insert Holders

Insert Holder		Weight	ISO Code	Insert Form	Part No.
K	X ₁				
80°	30.00	0.60 (kg)	SC..1204..	113	149089
80°	30.00	0.60 (kg)	SC..150512	114	149094
80°	30.00	0.60 (kg)	SN..1506..	134	149096

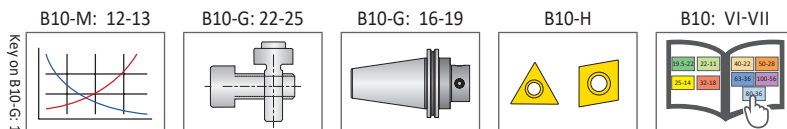
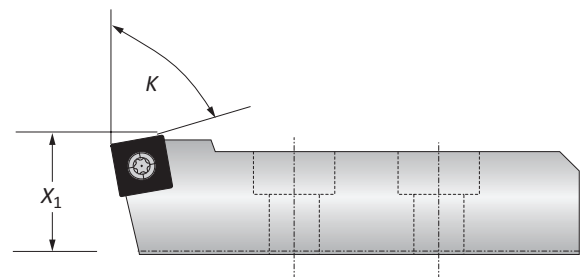

m = Metric (mm)

Inserts sold separately

WARNING Exceeding weight capacity for machine tool spindle and tool changer can cause machine damage and/or serious injury. To prevent:

-Consult machine tool builder for machine's weight limitations.

-Refer to example on page B10-M: 11 for calculating tool assembly weight

Factory technical assistance is also available for specific applications through our Application Engineering department. *email: engineering.eu@alliedmachine.com*

WARNING Tool failure can cause serious injury. To prevent:

-Do not exceed recommended 10xD length-to-diameter ratio or exceed 4 total components (including shank)

-When using Alu-Line® components, do not exceed recommended 5xD length-to-diameter ratio

-When using tool steel components, do not exceed recommended 6xD length-to-diameter ratio

-When using heavy metal components, do not exceed recommended 8xD length-to-diameter ratio

-When using a carbide shank, do not exceed recommended 9xD length-to-diameter ratio

-When using a NOVI^{TECH} module, do not exceed recommended 10xD length-to-diameter ratio

-Refer to examples on pages B10-M: 8-10 for calculating length-to-diameter ratio

Factory technical assistance is available for your specific applications through our Application Engineering department. *email: engineering.eu@alliedmachine.com*

A
B
C
D
E
F
G
H
I
J
K
L
M
INDEX

Insert Holders for Rough Machining | Boring Range Examples

Chamfering Insert Holders

m	Insert Holder				Weight	ISO Code	Insert Form	Part No.
	K	X ₁	A / A ₁	W				
	15°	30.00	+7.00	4.00	0.60 (kg)	TC..16T3..	163	201065
	20°	30.00	+9.00	5.30	0.60 (kg)	TC..16T3..	163	201025
	30°	30.00	+14.00	7.70	0.60 (kg)	TC..16T3..	163	201075
	45°	30.00	+20.00	9.90	0.60 (kg)	SC..1505..	114	201015

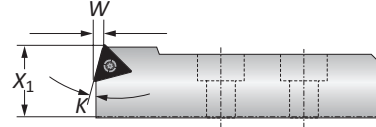
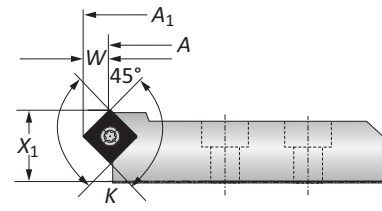

Back-Boring Insert Holders

m	Insert Holder				Weight	ISO Code	Insert Form	Part No.
	K	X ₁	X ₂	A				
	90°	30.00	5.00	+40.00	0.80 (kg)	CC..1204..	104	251010
	90°	30.00	5.00	+75.00	0.90 (kg)	CC..1204..	104	251011

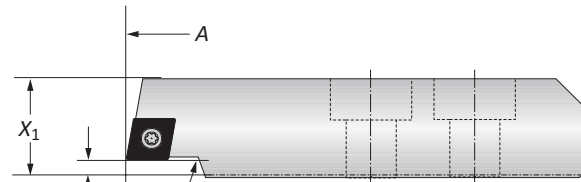

OD Turning Insert Holders

m	Insert Holder				Weight	ISO Code	Insert Form	Part No.
	K	X ₁	L ₁	A				
	90°	90.00	62.00	-50.00	1.00 (kg)	CC..1204..	104	149040

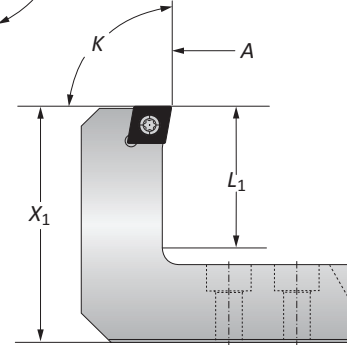

Boring Range Examples

m	Serrated Slide		Insert Holder		Total Bore Range
	Part No.	Bore Range	Part No.	Modified Bore Range	
		349051	200.00 - 280.00	201065	
	349051	200.00 - 280.00	251010	+40.00	240.00 - 320.00
	349051	200.00 - 280.00	149040	-50.00	150.00 - 230.00

NOTE: Boring range for serrated slides or base slides are found on pg. B10-G: 4 - 7

NOTE: Additional insert holders available upon request

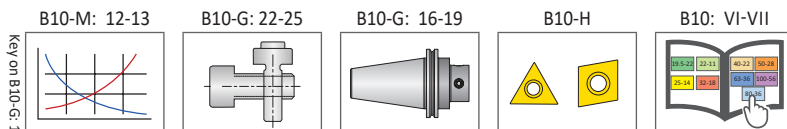

m = Metric (mm)

Inserts sold separately

WARNING Exceeding weight capacity for machine tool spindle and tool changer can cause machine damage and/or serious injury. To prevent:
 -Consult machine tool builder for machine's weight limitations.
 -Refer to example on page B10-M: 11 for calculating tool assembly weight
 Factory technical assistance is also available for specific applications through our Application Engineering department. *email: engineering.eu@alliedmachine.com*

WARNING Tool failure can cause serious injury. To prevent:
 -Do not exceed recommended 10xD length-to-diameter ratio or exceed 4 total components (including shank)
 -When using Alu-Line® components, do not exceed recommended 5xD length-to-diameter ratio
 -When using tool steel components, do not exceed recommended 6xD length-to-diameter ratio
 -When using heavy metal components, do not exceed recommended 8xD length-to-diameter ratio
 -When using a carbide shank, do not exceed recommended 9xD length-to-diameter ratio
 -When using a NOVITECH module, do not exceed recommended 10xD length-to-diameter ratio
 -Refer to examples on pages B10-M: 8-10 for calculating length-to-diameter ratio
 Factory technical assistance is available for your specific applications through our Application Engineering department. *email: engineering.eu@alliedmachine.com*

Insert Holders for Height Adjustments and Axial Grooving

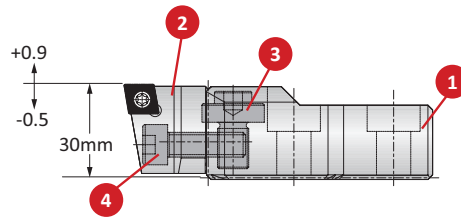

Insert Form 103

Boring Range	1 Support		2 Insert Holder		3 Adjusting Screw		4 Fixing Screw	
	Part No.	Insert Form	Part No.	Part No.	Service Key	Part No.	Service Key	
200.00 - 3255.00	149055	103	149058	315355	s6 / B	070369	s6 / B	

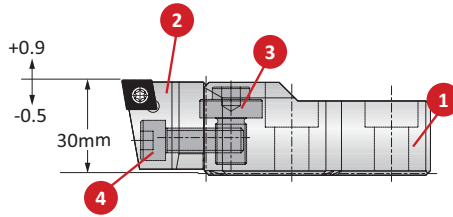

Insert Form 104

Boring Range	1 Support		2 Insert Holder		3 Adjusting Screw		4 Fixing Screw	
	Part No.	Insert Form	Part No.	Part No.	Service Key	Part No.	Service Key	
200.00 - 3255.00	149055	104	149056	315355	s6 / B	070369	s6 / B	

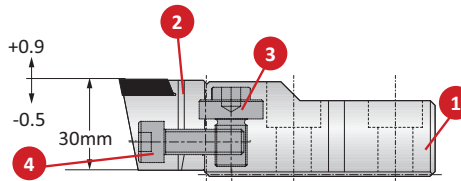

Insert Form 05

Boring Range	1 Support		2 Insert Holder		3 Adjusting Screw		4 Fixing Screw	
	Part No.	Insert Form	Part No.	Part No.	Service Key	Part No.	Service Key	
200.00 - 3255.00	149055	05	149085	315355	s6 / B	070369	s6 / B	

Insert Holder for Axial Grooving

Insert Holder	1 Support	2 Insert Holder	Weight	Insert Form
X_1	Part No.	Part No.		
40.00	226014	226031	0.30 (kg)	304

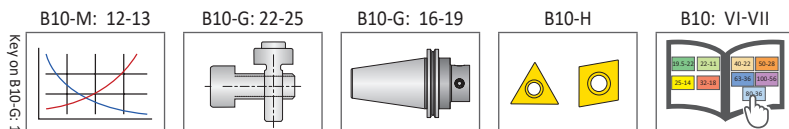
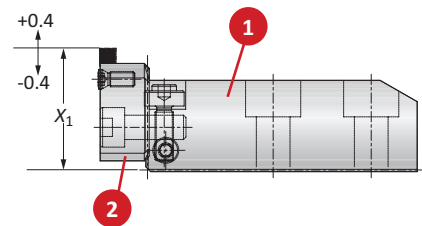

m = Metric (mm)
Inserts sold separately

WARNING Exceeding weight capacity for machine tool spindle and tool changer can cause machine damage and/or serious injury. To prevent:
 -Consult machine tool builder for machine's weight limitations.
 -Refer to example on page B10-M: 11 for calculating tool assembly weight
 Factory technical assistance is also available for specific applications through our Application Engineering department. *email: engineering.eu@alliedmachine.com*

WARNING Tool failure can cause serious injury. To prevent:
 -Do not exceed recommended 10xD length-to-diameter ratio or exceed 4 total components (including shank)
 -When using Alu-Line® components, do not exceed recommended 5xD length-to-diameter ratio
 -When using tool steel components, do not exceed recommended 6xD length-to-diameter ratio
 -When using heavy metal components, do not exceed recommended 8xD length-to-diameter ratio
 -When using a carbide shank, do not exceed recommended 9xD length-to-diameter ratio
 -When using a NOVITECH module, do not exceed recommended 10xD length-to-diameter ratio
 -Refer to examples on pages B10-M: 8-10 for calculating length-to-diameter ratio
 Factory technical assistance is available for your specific applications through our Application Engineering department. *email: engineering.eu@alliedmachine.com*

A
B
C
D
E
F
G
H
I
J
K
L
M
INDEX



MVS Holding Arbors D 40 / D 60

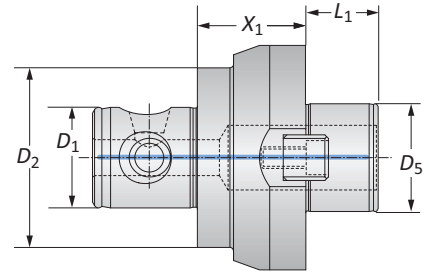
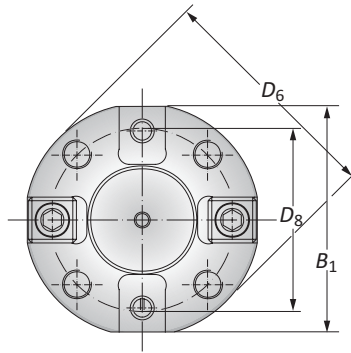

MVS Connection	Holding Arbor Connection	Holding Arbor						Weight	Part No.
		X_1	L_1	D_5	D_6	D_8	B_1		
$D_2 D_1$									
80 - 36	D 40 Alu-Line	19.00	30.00	40.00	89.00	66.70	80.00	0.50 (kg)	309001 ⁽¹⁾⁽²⁾
80 - 36	D 60	60.00	40.00	60.00	129.10	101.60	125.00	4.10 (kg)	209060 ⁽¹⁾
100 - 56	D 40 Alu-Line	30.00	30.00	40.00	89.00	66.70	80.00	1.00 (kg)	309041 ⁽²⁾
100 - 56	D 60	60.00	40.00	60.00	129.10	101.60	125.00	6.30 (kg)	209043
100 - 56	D 60 Alu-Line	60.00	40.00	60.00	129.10	101.60	125.00	2.20 (kg)	309043 ⁽²⁾

(1) For light machining only

(2) Lightweight aluminium construction only in connection with our serrated slides

Basic D 40 Serrated Slides: \varnothing 200.00 - 520.00 mm (Page B10-E: 4)

Basic D 60 Serrated Slides: \varnothing 200.00 - 505.00 mm (Page B10-E: 5)

B10-M: 12-13

B10: VI-VII

Key on B10-G: 1

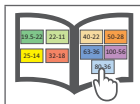
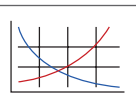

m = Metric (mm)

WARNING Exceeding weight capacity for machine tool spindle and tool changer can cause machine damage and/or serious injury. To prevent:
 -Consult machine tool builder for machine's weight limitations.
 -Refer to example on page B10-M: 11 for calculating tool assembly weight
 Factory technical assistance is also available for specific applications through our Application Engineering department. *email: engineering.eu@alliedmachine.com*

WARNING Tool failure can cause serious injury. To prevent:
 -Do not exceed recommended 10xD length-to-diameter ratio or exceed 4 total components (including shank)
 -When using Alu-Line® components, do not exceed recommended 5xD length-to-diameter ratio
 -When using tool steel components, do not exceed recommended 6xD length-to-diameter ratio
 -When using heavy metal components, do not exceed recommended 8xD length-to-diameter ratio
 -When using a carbide shank, do not exceed recommended 9xD length-to-diameter ratio
 -When using a NOVITECH module, do not exceed recommended 10xD length-to-diameter ratio
 -Refer to examples on pages B10-M: 8-10 for calculating length-to-diameter ratio
 Factory technical assistance is available for your specific applications through our Application Engineering department. *email: engineering.eu@alliedmachine.com*

Master Shanks D 40 / D 60

HSK-A (DIN 69 893) Shanks

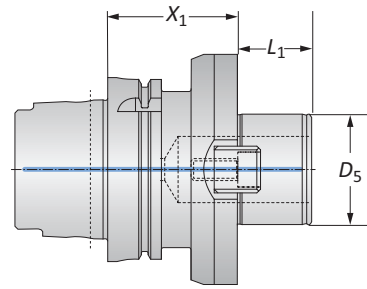
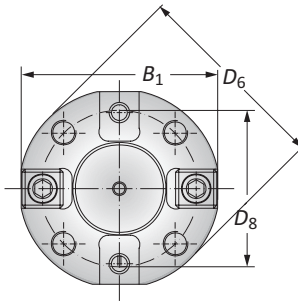

HSK-A (DIN 69 893) Shanks

Taper Size	Connection	Shank							Weight	Part No.
		X_1	L_1	D_5	D_6	D_8	B_1			
63	D 40	60.00	30.00	40.00	89.00	66.70	80.00	1.90 (kg)	358015	
100	D 40	60.00	30.00	40.00	89.00	66.70	80.00	3.60 (kg)	258021	
100	D 60	70.00	40.00	60.00	129.10	101.60	125.00	5.20 (kg)	258061	
100	D 60	70.00	40.00	60.00	129.10	101.60	110.00	5.00 (kg)	258098	

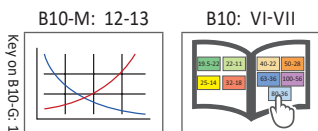

Ⓜ = Metric (mm)

⚠ WARNING Exceeding weight capacity for machine tool spindle and tool changer can cause machine damage and/or serious injury. To prevent:
 -Consult machine tool builder for machine's weight limitations.
 -Refer to example on page B10-M: 11 for calculating tool assembly weight
 Factory technical assistance is also available for specific applications through our Application Engineering department. *email: engineering.eu@alliedmachine.com*

⚠ WARNING Tool failure can cause serious injury. To prevent:
 -Do not exceed recommended 10xD length-to-diameter ratio or exceed 4 total components (including shank)
 -When using Alu-Line® components, do not exceed recommended 5xD length-to-diameter ratio
 -When using tool steel components, do not exceed recommended 6xD length-to-diameter ratio
 -When using heavy metal components, do not exceed recommended 8xD length-to-diameter ratio
 -When using a carbide shank, do not exceed recommended 9xD length-to-diameter ratio
 -When using a NOVI^{TECH} module, do not exceed recommended 10xD length-to-diameter ratio
 -Refer to examples on pages B10-M: 8-10 for calculating length-to-diameter ratio
 Factory technical assistance is available for your specific applications through our Application Engineering department. *email: engineering.eu@alliedmachine.com*

Master Shanks D 40

CAT 50 Shank with Metric Threads

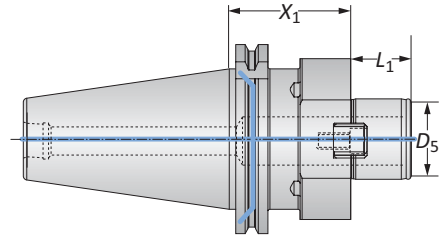
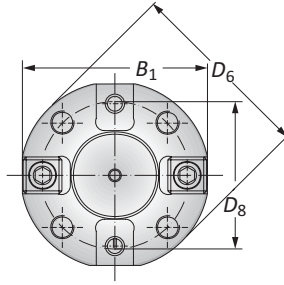

CAT 50 Shanks with Metric Threads

Taper Size	Connection	Shank						Weight	Part No.
		X_1	L_1	D_5	D_6	D_8	B_1		
 50	D 40	60.00	30.00	40.00	89.00	66.70	80.00	4.60 (kg)	326083

B10-M: 12-13

B10: VI-VII

Key on B10-G: I

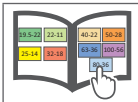
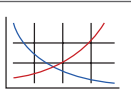

 = Metric (mm)

⚠ WARNING Exceeding weight capacity for machine tool spindle and tool changer can cause machine damage and/or serious injury. To prevent:
 -Consult machine tool builder for machine's weight limitations.
 -Refer to example on page B10-M: 11 for calculating tool assembly weight
 Factory technical assistance is also available for specific applications through our Application Engineering department. *email: engineering.eu@alliedmachine.com*

⚠ WARNING Tool failure can cause serious injury. To prevent:
 -Do not exceed recommended 10xD length-to-diameter ratio or exceed 4 total components (including shank)
 -When using Alu-Line® components, do not exceed recommended 5xD length-to-diameter ratio
 -When using tool steel components, do not exceed recommended 6xD length-to-diameter ratio
 -When using heavy metal components, do not exceed recommended 8xD length-to-diameter ratio
 -When using a carbide shank, do not exceed recommended 9xD length-to-diameter ratio
 -When using a NOVITECH™ module, do not exceed recommended 10xD length-to-diameter ratio
 -Refer to examples on pages B10-M: 8-10 for calculating length-to-diameter ratio
 Factory technical assistance is available for your specific applications through our Application Engineering department. *email: engineering.eu@alliedmachine.com*

Master Shanks D 40 / D 60

SK (DIN 69 871-AD/B) | BT / JIS B 6339 Shanks

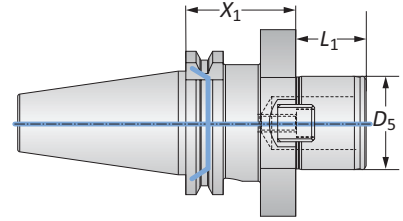
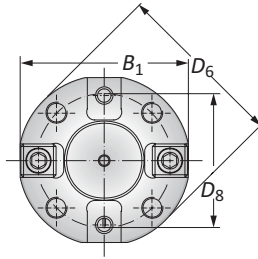

SK (DIN 69 871-AD/B) Shanks

Taper Size	Connection	Shank							Weight	Part No.
		X_1	L_1	D_5	D_6	D_8	B_1			
m	40	D 40	50.00	30.00	40.00	89.00	66.70	80.00	1.90 (kg)	326080*
	50	D 40	50.00	30.00	40.00	89.00	66.70	80.00	4.10 (kg)	326081
	50	D 60	70.00	40.00	60.00	129.10	101.60	125.00	5.80 (kg)	198054T019539
	50	D 60	70.00	40.00	60.00	129.10	101.60	110.00	5.50 (kg)	198081T019539

*For light machining only

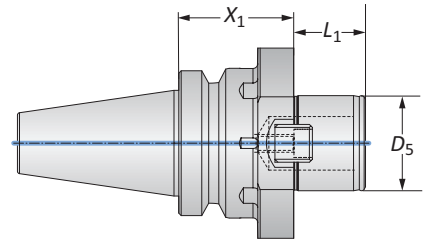
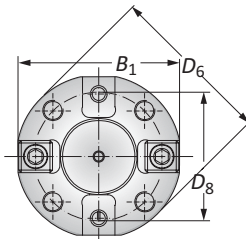

BT / JIS B 6339 Shanks

Taper Size	Connection	Shank							Weight	Part No.
		X_1	L_1	D_5	D_6	D_8	B_1			
m	40	D 40	50.00	30.00	40.00	89.00	66.70	80.00	1.80 (kg)	326084
	50	D 40	55.00	30.00	40.00	89.00	66.70	80.00	4.50 (kg)	326082
	50	D 60	80.00	40.00	60.00	19.10	101.60	-	8.00 (kg)	326062

B10-M: 12-13

B10: VI-VII

Key on B10-G: 1

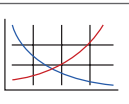

m = Metric (mm)

WARNING Exceeding weight capacity for machine tool spindle and tool changer can cause machine damage and/or serious injury. To prevent:

-Consult machine tool builder for machine's weight limitations.

-Refer to example on page B10-M: 11 for calculating tool assembly weight

Factory technical assistance is also available for specific applications through our Application Engineering department. *email: engineering.eu@alliedmachine.com*

WARNING Tool failure can cause serious injury. To prevent:

-Do not exceed recommended 10xD length-to-diameter ratio or exceed 4 total components (including shank)

-When using Alu-Line® components, do not exceed recommended 5xD length-to-diameter ratio

-When using tool steel components, do not exceed recommended 6xD length-to-diameter ratio

-When using heavy metal components, do not exceed recommended 8xD length-to-diameter ratio

-When using a carbide shank, do not exceed recommended 9xD length-to-diameter ratio

-When using a NOVITECH module, do not exceed recommended 10xD length-to-diameter ratio

-Refer to examples on pages B10-M: 8-10 for calculating length-to-diameter ratio

Factory technical assistance is available for your specific applications through our Application Engineering department. *email: engineering.eu@alliedmachine.com*

Master Shanks D 60

NMTB Shanks | DIN 2080 Shanks

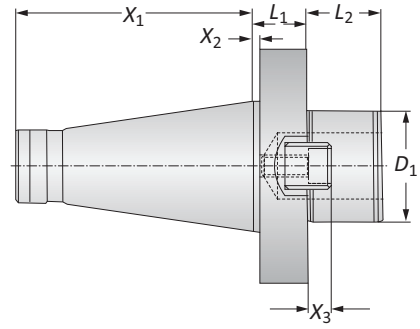
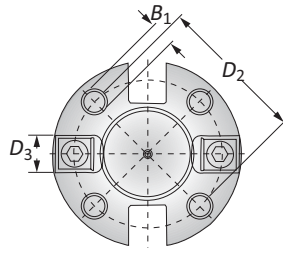

NMTB Shanks

Taper Size	Connection	Shank									Weight	Part No.
		X_1	X_2	L_1	L_2	D_1	X_3	D_2	D_3	B_1		
 50	D 60	126.80	3.20	29.00	40.00	60.00	12.50	101.60	25.40	M16	8.00 (kg)	198051T004480

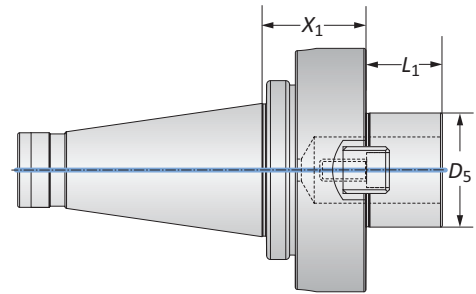
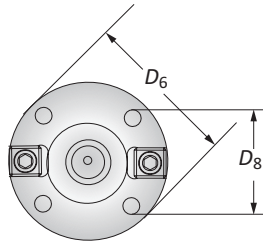

DIN 2080 Shanks

Taper Size	Connection	Shank						Weight	Part No.
		X_1	L_1	D_5	D_6	D_8	B_1		
 50	D 60	55.00	40.00	60.00	128.00	101.60	-	6.80 (kg)	326035

B10-M: 12-13

B10: VI-VII

Key on B10-G: 1

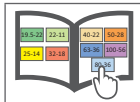
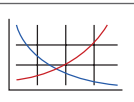

 = Metric (mm)

⚠ WARNING Exceeding weight capacity for machine tool spindle and tool changer can cause machine damage and/or serious injury. To prevent:
 -Consult machine tool builder for machine's weight limitations.
 -Refer to example on page B10-M: 11 for calculating tool assembly weight
 Factory technical assistance is also available for specific applications through our Application Engineering department. *email: engineering.eu@alliedmachine.com*

⚠ WARNING Tool failure can cause serious injury. To prevent:
 -Do not exceed recommended 10xD length-to-diameter ratio or exceed 4 total components (including shank)
 -When using Alu-Line® components, do not exceed recommended 5xD length-to-diameter ratio
 -When using tool steel components, do not exceed recommended 6xD length-to-diameter ratio
 -When using heavy metal components, do not exceed recommended 8xD length-to-diameter ratio
 -When using a carbide shank, do not exceed recommended 9xD length-to-diameter ratio
 -When using a NOVITECH module, do not exceed recommended 10xD length-to-diameter ratio
 -Refer to examples on pages B10-M: 8-10 for calculating length-to-diameter ratio
 Factory technical assistance is available for your specific applications through our Application Engineering department. *email: engineering.eu@alliedmachine.com*

537 Accessories

Clamping Pieces | Counter Weight | Insert Holders for Abrasive Materials

537 Clamping Pieces

Slide Type	Complete Part No.	Service Key		Replacement Components		
				1 Cap Screw	2 Clamping Nut	3 Disk Spring
Serrated Tool Bodies	137026	115578	s6 / B	215101	140118	337105
Basic and Eco Slides	137027			215102	215105	337105
Flex Slides	137019			415900	215105	337105

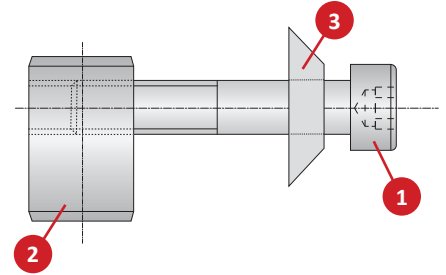

NOTE: Clamping pieces sold separately

537 Counter Weight

Boring Range	Part No.
m 100.00 - 3255.00	537055

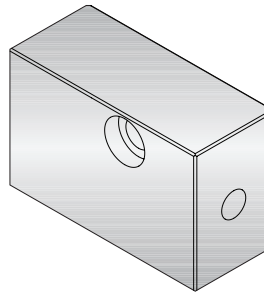

Insert Holders for Abrasive Materials

Boring Range	L ₁	Weight	Insert Form	Part No.
m 100.00 - 3255.00	18.00	0.03 (kg)	20	211061
100.00 - 3255.00	18.00	0.03 (kg)	101	211063
100.00 - 3255.00	18.00	0.03 (kg)	103	211065

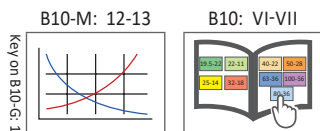
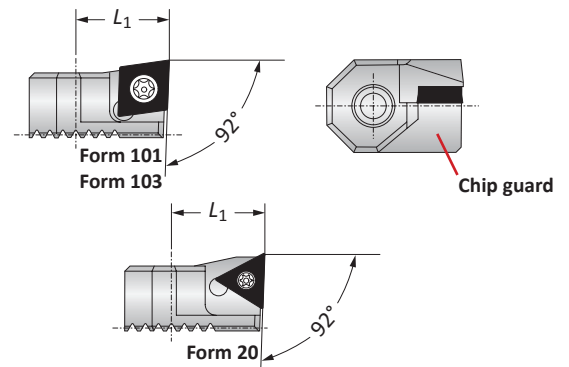

m = Metric (mm)

Inserts sold separately

WARNING Exceeding weight capacity for machine tool spindle and tool changer can cause machine damage and/or serious injury. To prevent:
 -Consult machine tool builder for machine's weight limitations.
 -Refer to example on page B10-M: 11 for calculating tool assembly weight
 Factory technical assistance is also available for specific applications through our Application Engineering department. *email: engineering.eu@alliedmachine.com*

WARNING Tool failure can cause serious injury. To prevent:
 -Do not exceed recommended 10xD length-to-diameter ratio or exceed 4 total components (including shank)
 -When using Alu-Line® components, do not exceed recommended 5xD length-to-diameter ratio
 -When using tool steel components, do not exceed recommended 6xD length-to-diameter ratio
 -When using heavy metal components, do not exceed recommended 8xD length-to-diameter ratio
 -When using a carbide shank, do not exceed recommended 9xD length-to-diameter ratio
 -When using a NOVITECH module, do not exceed recommended 10xD length-to-diameter ratio
 -Refer to examples on pages B10-M: 8-10 for calculating length-to-diameter ratio
 Factory technical assistance is available for your specific applications through our Application Engineering department. *email: engineering.eu@alliedmachine.com*

537 Accessories | 3E^{TECH+} Accessories

Accessories

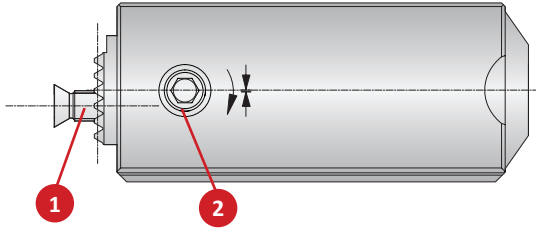

537 Analogue Cassette

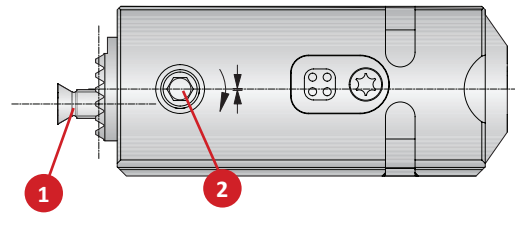

537 Digital Cassette

537 Accessories

Cassette Part No.	1 Countersunk Screw		2 Clamping Screw	
	Part No.	Service Key	Part No.	Service Key
537051	215462	T20 / H	115249	s4 / F
537052	215462	T20 / H	315789	s4 / F

3E^{TECH+} Accessories

1
Charging Unit
Part No.
536016



NOTE: Charging unit sold separately from 3E^{TECH+}

NOTE: 3E^{TECH+} adjustment accuracy of 0.001 mm on diameter

3E^{TECH} Accessories (Old Display)

1	2
Sealing Ring	Battery CR2032
Part No.	Part No.
215483	515491

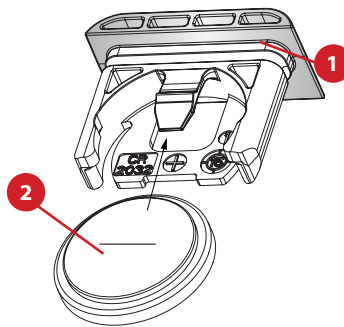

NOTE: Not required for 3E^{TECH+} (New Display)

B10-M: 12-13

B10: VI-VII

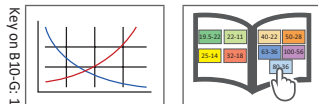

m = Metric (mm)

Inserts sold separately

WARNING Exceeding weight capacity for machine tool spindle and tool changer can cause machine damage and/or serious injury. To prevent:

-Consult machine tool builder for machine's weight limitations.

-Refer to example on page B10-M: 11 for calculating tool assembly weight

Factory technical assistance is also available for specific applications through our Application Engineering department. *email: engineering.eu@alliedmachine.com*

WARNING Tool failure can cause serious injury. To prevent:

-Do not exceed recommended 10xD length-to-diameter ratio or exceed 4 total components (including shank)

-When using Alu-Line® components, do not exceed recommended 5xD length-to-diameter ratio

-When using tool steel components, do not exceed recommended 6xD length-to-diameter ratio

-When using heavy metal components, do not exceed recommended 8xD length-to-diameter ratio

-When using a carbide shank, do not exceed recommended 9xD length-to-diameter ratio

-When using a NOVITECH module, do not exceed recommended 10xD length-to-diameter ratio

-Refer to examples on pages B10-M: 8-10 for calculating length-to-diameter ratio

Factory technical assistance is available for your specific applications through our Application Engineering department. *email: engineering.eu@alliedmachine.com*

Serrated Slide Basic D 40 Accessories

Clamping Pieces

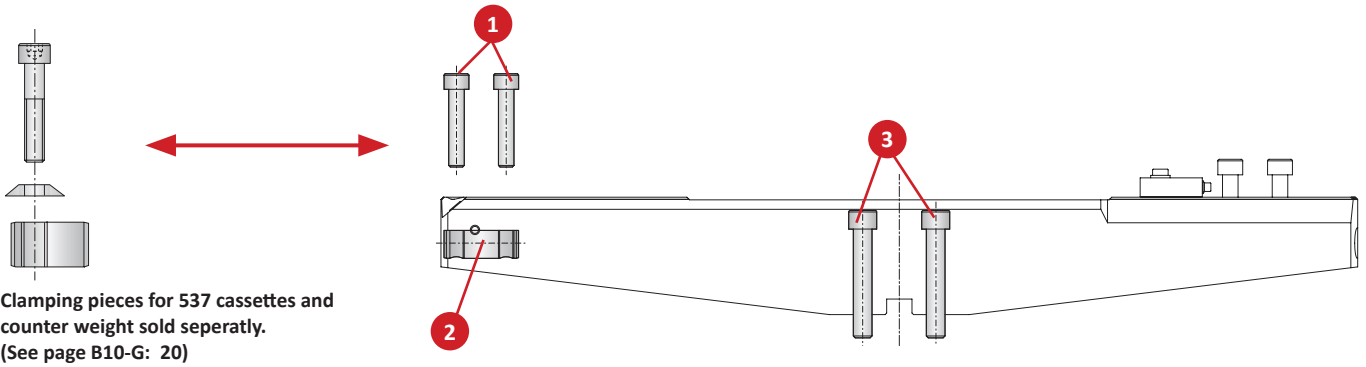

Clamping pieces for 537 cassettes and counter weight sold separately. (See page B10-G: 20)

Clamping Pieces

Connection	Serrated Slide	1 Cap Screw		2 Clamping Nut	3 Thread Pin		Cap Screw		
	Part No.	Part No.	Service Key	Part No.	Part No.	Service Key	Part No.	Service Key	
m	D 40	349021	115118	s8 / B	115669	349010	s4 / F	315186	s10 / C
	D 40	349022	115118	s8 / B	115669	349011	s4 / F	315186	s10 / C
	D 40	349023	115118	s8 / B	115669	349012	s4 / F	315186	s10 / C
	D 40	349024	115118	s8 / B	115669	349013	s4 / F	315186	s10 / C

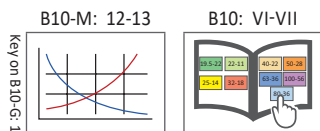

m = Metric (mm)

WARNING Exceeding weight capacity for machine tool spindle and tool changer can cause machine damage and/or serious injury. To prevent:
 -Consult machine tool builder for machine's weight limitations.
 -Refer to example on page B10-M: 11 for calculating tool assembly weight
 Factory technical assistance is also available for specific applications through our Application Engineering department. *email: engineering.eu@alliedmachine.com*

WARNING Tool failure can cause serious injury. To prevent:
 -Do not exceed recommended 10xD length-to-diameter ratio or exceed 4 total components (including shank)
 -When using Alu-Line® components, do not exceed recommended 5xD length-to-diameter ratio
 -When using tool steel components, do not exceed recommended 6xD length-to-diameter ratio
 -When using heavy metal components, do not exceed recommended 8xD length-to-diameter ratio
 -When using a carbide shank, do not exceed recommended 9xD length-to-diameter ratio
 -When using a NOVI^{TECH} module, do not exceed recommended 10xD length-to-diameter ratio
 -Refer to examples on pages B10-M: 8-10 for calculating length-to-diameter ratio
 Factory technical assistance is available for your specific applications through our Application Engineering department. *email: engineering.eu@alliedmachine.com*



Serrated Slide Basic D 60 Accessories

Clamping Pieces | Cover Plates

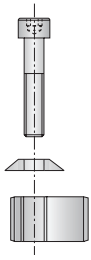

Clamping pieces for 537 cassettes and counter weight sold separately. (See page B10-G: 20)

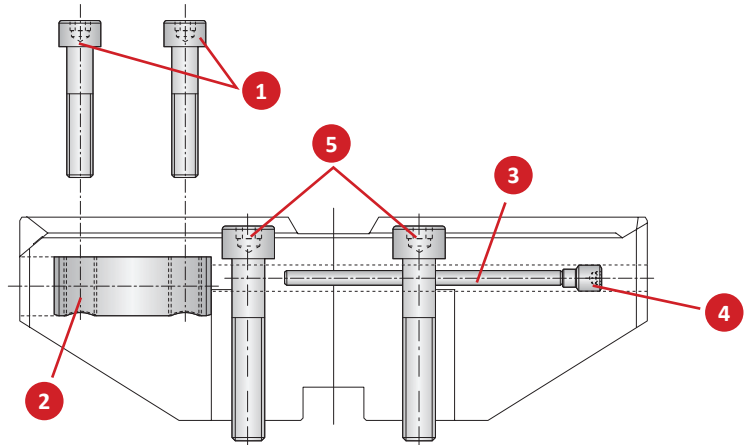

Cover Plates for Basic D 60 Serrated Slides

Connection	Serrated Slide Part No.	1 Cover Plate			2 Countersunk Screw	
		Part No.	Part No.	Part No.	Service Key	
m	D 60	349051	349016	063106	s4 / B	
	D 60	349052	349017	063106	s4 / B	
	D 60	349053	349017	063106	s4 / B	
	D 60	349054	349017	063106	s4 / B	

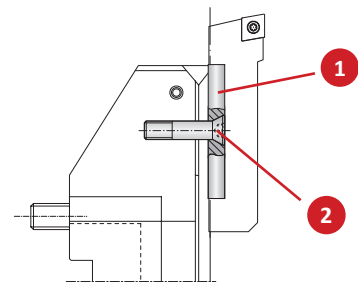

B10-M: 12-13 B10: VI-VII

key on B10-G: 1

m = Metric (mm)

WARNING Exceeding weight capacity for machine tool spindle and tool changer can cause machine damage and/or serious injury. To prevent:
 -Consult machine tool builder for machine's weight limitations.
 -Refer to example on page B10-M: 11 for calculating tool assembly weight
 Factory technical assistance is also available for specific applications through our Application Engineering department. *email: engineering.eu@alliedmachine.com*

WARNING Tool failure can cause serious injury. To prevent:
 -Do not exceed recommended 10xD length-to-diameter ratio or exceed 4 total components (including shank)
 -When using Alu-Line® components, do not exceed recommended 5xD length-to-diameter ratio
 -When using tool steel components, do not exceed recommended 6xD length-to-diameter ratio
 -When using heavy metal components, do not exceed recommended 8xD length-to-diameter ratio
 -When using a carbide shank, do not exceed recommended 9xD length-to-diameter ratio
 -When using a NOVITECH module, do not exceed recommended 10xD length-to-diameter ratio
 -Refer to examples on pages B10-M: 8-10 for calculating length-to-diameter ratio
 Factory technical assistance is available for your specific applications through our Application Engineering department. *email: engineering.eu@alliedmachine.com*

A
B
C
D
E
F
G
H
I
J
K
L
M
INDEX

Serrated Slide Eco D 60 Accessories

Clamping Pieces

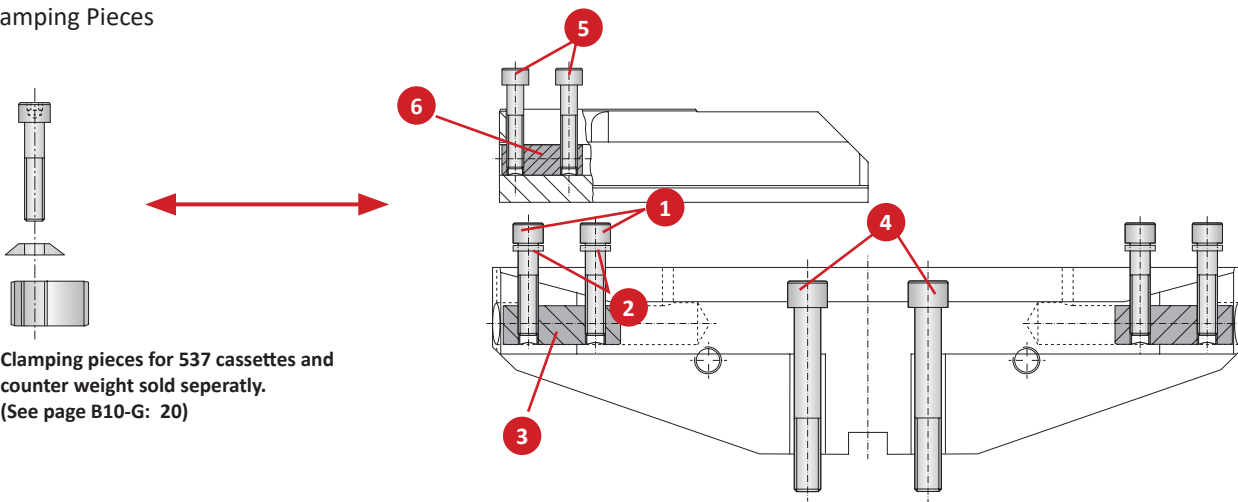

Clamping pieces for 537 cassettes and counter weight sold separately. (See page B10-G: 20)

Base Slide Clamping Pieces

Connection	Base Slide Part No.	1 Cap Screw		2 Disc	3 Clamping Nut	4 Cap Screw	
		Part No.	Service Key	Part No.	Part No.	Part No.	Service Key
D 60	349005	115771	s10 / C	115737	415181	077128	s14 / C
	349006	115771	s10 / C	115737	415181	077128	s14 / C

Serrated Slide Clamping Pieces

Serrated Slide Part No.	5 Cap Screw		6 Clamping Nut
	Part No.	Service Key	Part No.
349014	115118	s8 / B	115669
349015	115118	s8 / B	115669

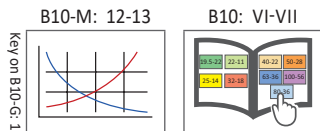

Ⓜ = Metric (mm)

⚠ WARNING Exceeding weight capacity for machine tool spindle and tool changer can cause machine damage and/or serious injury. To prevent:
 -Consult machine tool builder for machine's weight limitations.
 -Refer to example on page B10-M: 11 for calculating tool assembly weight
 Factory technical assistance is also available for specific applications through our Application Engineering department. *email: engineering.eu@alliedmachine.com*

⚠ WARNING Tool failure can cause serious injury. To prevent:
 -Do not exceed recommended 10xD length-to-diameter ratio or exceed 4 total components (including shank)
 -When using Alu-Line® components, do not exceed recommended 5xD length-to-diameter ratio
 -When using tool steel components, do not exceed recommended 6xD length-to-diameter ratio
 -When using heavy metal components, do not exceed recommended 8xD length-to-diameter ratio
 -When using a carbide shank, do not exceed recommended 9xD length-to-diameter ratio
 -When using a NOVITECH module, do not exceed recommended 10xD length-to-diameter ratio
 -Refer to examples on pages B10-M: 8-10 for calculating length-to-diameter ratio
 Factory technical assistance is available for your specific applications through our Application Engineering department. *email: engineering.eu@alliedmachine.com*

Serrated Slide Flex D 60 Accessories

Clamping Pieces

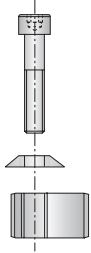

Clamping pieces for 537 cassettes and counter weight sold separately. (See page B10-G: 20)

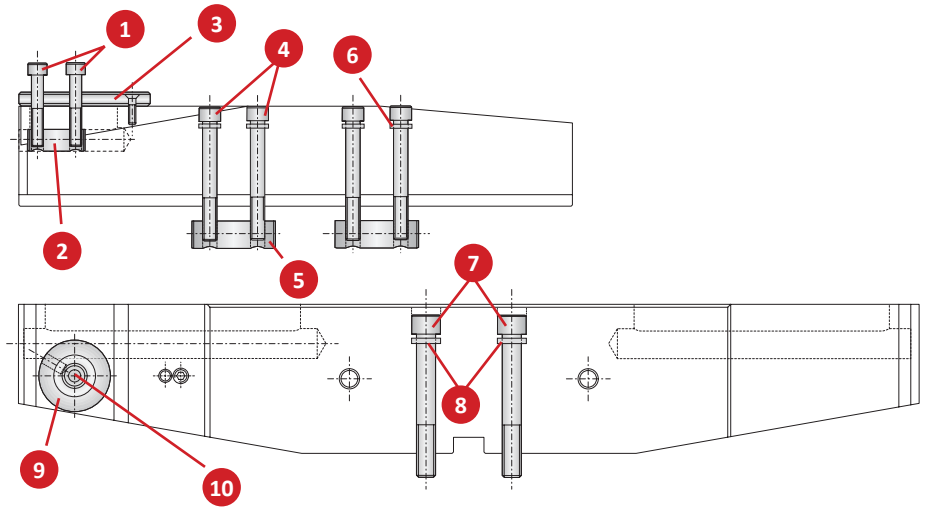

Serrated Slide Clamping Pieces

Serrated Slide	1 Cap Screw		2 Clamping Nut		3 Adapter		4 Cap Screw		5 Clamping Nut		6 Disk	
	Part No.	Service Key	Part No.	Service Key	Part No.	Service Key	Part No.	Service Key	Part No.	Service Key	Part No.	Service Key
m	349035	115307	s8 / B	115669	349043	s4 / B	315186	s10 / C	349202	415898	115737	s6 / B
	349036	115307	s8 / B	115669	349043	s4 / B	077110	s10 / C	415181	415898	115737	s6 / B
	349037	115307	s8 / B	115669	349043	s4 / B	315403	s10 / C	415181	415898	115737	s6 / B
	349038	115307	s8 / B	115669	349043	s4 / B	315415	s10 / C	415181	415898	115737	s6 / B

Base Slide Clamping Pieces

Connection	Base Slide		7 Cap Screw		8 Disk		9 Injector		10 Countersunk Screw	
	Part No.	Service Key	Part No.	Service Key	Part No.	Service Key	Part No.	Service Key	Part No.	Service Key
m	D 60	349031	115736	s14 / C	068168	s14 / C	349201	s14 / C	415898	s6 / B
	D 60	349032	415913	s14 / C	068168	s14 / C	349201	s14 / C	415898	s6 / B
	D 60	349033	215509	s14 / C	068168	s14 / C	349201	s14 / C	415898	s6 / B
	D 60	349034	415636	s14 / C	068168	s14 / C	349201	s14 / C	415898	s6 / B

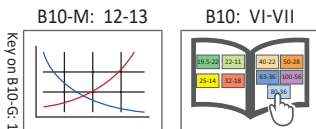

m = Metric (mm)

WARNING Exceeding weight capacity for machine tool spindle and tool changer can cause machine damage and/or serious injury. To prevent:
 -Consult machine tool builder for machine's weight limitations.
 -Refer to example on page B10-M: 11 for calculating tool assembly weight
 Factory technical assistance is also available for specific applications through our Application Engineering department. *email: engineering.eu@alliedmachine.com*

WARNING Tool failure can cause serious injury. To prevent:
 -Do not exceed recommended 10xD length-to-diameter ratio or exceed 4 total components (including shank)
 -When using Alu-Line® components, do not exceed recommended 5xD length-to-diameter ratio
 -When using tool steel components, do not exceed recommended 6xD length-to-diameter ratio
 -When using heavy metal components, do not exceed recommended 8xD length-to-diameter ratio
 -When using a carbide shank, do not exceed recommended 9xD length-to-diameter ratio
 -When using a NOVITECH module, do not exceed recommended 10xD length-to-diameter ratio
 -Refer to examples on pages B10-M: 8-10 for calculating length-to-diameter ratio
 Factory technical assistance is available for your specific applications through our Application Engineering department. *email: engineering.eu@alliedmachine.com*

SECTION

B10-H

Inserts

Wohlhaupter® Inserts

Replaceable Boring Inserts

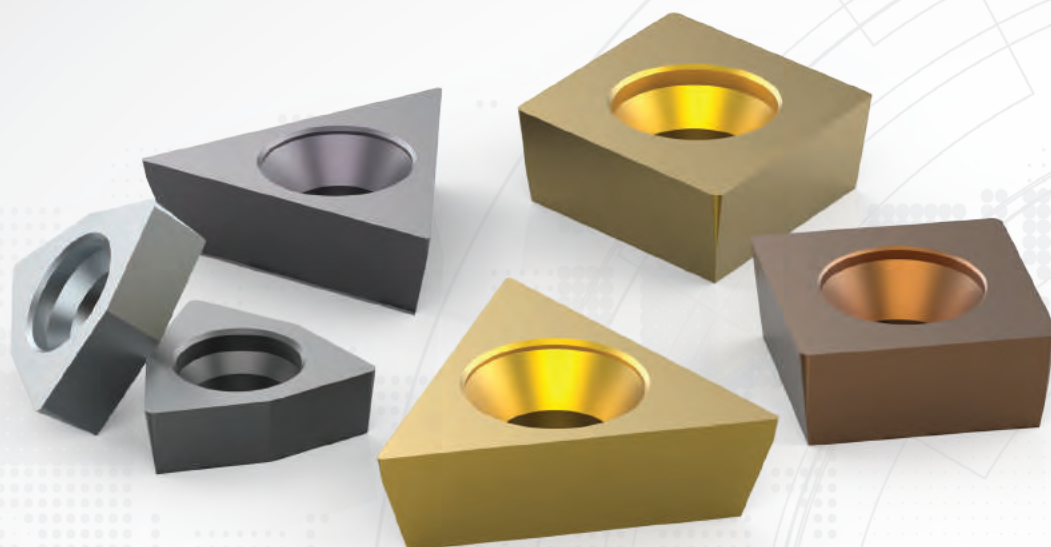

Cutting-Edge Technology

Wohlhaupter has the cutting-edge technology to achieve all of your boring applications. With precision in mind, our inserts are available in multiple insert geometries, coatings, and nose radii. Wohlhaupter inserts are offered in uncoated and coated carbide, cermet, as well as CBN and PCD materials.

Try our easy-to-use boring insert selector available online or to download from the app store to find the perfect inserts for your boring applications.

www.alliedmachine.com/bis

Applicable Industries



Aerospace



Agriculture



Automotive



Firearms



General
Machining



Oil & Gas



Renewable
Energy

Your safety and the safety of others is very important. This catalogue contains important safety messages. Always read and follow all safety precautions.



This triangle is a safety hazard symbol. It alerts you to potential safety hazards that can cause tool failure and serious injury.

When you see this symbol in the catalogue, look for a related safety message that may be near this triangle or referred to in the nearby text.

There are safety signal words also used in the catalogue. Safety messages follow these words.

WARNING

WARNING (shown above) means that failure to follow the precautions in this message could result in tool failure and serious injury.

NOTICE means that failure to follow the precautions in this message could result in damage to the tool or machine but not result in personal injury.

NOTE and **IMPORTANT** are also used. These are important that you read and follow but are not safety-related.

Visit www.alliedmachine.com for the most up-to-date information and procedures.

Wohlhaupter® Inserts Table of Contents

Reference Icons

The following icons will appear throughout the catalogue to help you navigate between products.

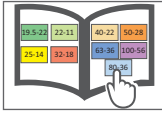

MVS Connection Colour Guide

Detailed instructions and information regarding the MVS connection(s)

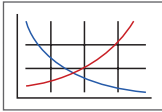

Recommended Cutting Data

Speed and feed recommendations for optimum and safe boring

Product Nomenclature

Wohlhaupter Insert Nomenclature	2
ISO Insert Nomenclature	3

Insert Grades

Insert Geometries

Insert Forms

Form 211	14 - 15
Form 20	16 - 17
Form 161 and 163	18
Form 47	19
Form 101, 103, 104, and 105	20 - 23
Form 101, 103 and 104	24 - 25
Form 39	26 - 27
Form 112, 113, and 114	28
Form 04 and 05	29
Grooving Insert Form 89, 90, and 91	30 - 31
Grooving Insert Form 304	32 - 34
Grooving Insert Form 325	35

Insert Accessories

Technical Information

Surface Finish and General Formulas	38
Wiper Geometries	39
Recommended Cutting Data	40 - 41

Wear Patterns

WOHLHAUPTER®

Boring Insert Selector

Find the best insert for your application.

- Generate the correct boring insert for your job in just six easy steps
- Choose type, shape, substrate, insert form, nose radius, and material
- Order easily by adding the item to your cart

www.alliedmahcine.com/bis



Wohlhaupter Insert Nomenclature

Reference Key

Symbol	Insert Type
▼	Roughing - Main Application
▽	Roughing - Extended Application
▼▼	Universal - Main Application
▽▽	Universal - Extended Application
▼▼▼	Finishing - Main Application
▽▽▽	Finishing - Extended Application

Reference Key

Symbol	Machining Conditions
●	Good - Main Application
○	Good - Extended Application
●	Average - Main Application
○	Average - Extended Application
⚙	Difficult - Main Application
⚙	Difficult - Extended Application

Reference Key

Symbol	Wohlhaupter Insert Grades
WHW	Uncoated carbide (HW)
WHC	Coated carbide (HC)
WHT	Uncoated cermet (HT)
WTC	Coated cermet (HC)
WCN	Ceramic cutting material (CN)
WBN	Cubic boron nitride CBN (BN)
WBC	Coated CBN (BC)
PCD	Polycrystalline diamond PCD (DP)

Wohlhaupter Inserts

F101	04	M	N	-	158	W	D
1	2	3	4		5	6	7

1. Wohlhaupter Insert Form	
211	262
20	264
161	112
163	113
47	114
101	04
103	05
104	89
105	90
123	91
124	304
39	325
75	

2. Corner Radius	
Metric (mm)	
005 = 0.05 mm	
01 = 0.10 mm	
02 = 0.20 mm	
03 = 0.30 mm	
04 = 0.40 mm	
06 = 0.60 mm	
08 = 0.80 mm	
12 = 1.20 mm	
16 = 1.60 mm	
20 = 2.00 mm	
24 = 2.40 mm	

3. Tolerance Group		
Metric (mm)		
G	Length of edge	±0.025
	IC	±0.025
M	Thickness	±0.13
	Length of edge	±0.08-0.15*
F	IC	±0.05-0.10*
	Thickness	±0.13
C	Length of edge	±0.013
	IC	±0.005
F	Thickness	±0.025
	Length of edge	±0.13
C	IC	±0.025
	Thickness	±0.025

*Varies upon insert size

4. Machining Direction
N = Neutral
L = Left
R = Right

5. Geometry						
Carbide	Carbide	Tangential	Ceramic	PCD	CBN	
108	155	880	711	720	741	
109	158	811		730	742	
112	161			735	745	
114	174W				747	
121	192				748	
122	199				749	
126	200				768	
127	650					
128	711					
129	840					
145	850					
146	860					

6. / 7. Optional Information
W = Wiper Geometry
D = Double Tipped
T = Triple Tipped

ISO Insert Nomenclature

DIN ISO 1832

C	C	M	T	09	T3	02
1	2	3	4	5	6	7

1. Basic Insert Form
C = Rhomboid 80°
D = Rhomboid 55°
L = Rectangular
R = Round
S = Square
T = Triangular
V = Rhomboid 35°
W = Trigon

2. Clearance Angle
B = 5°
C = 7°
N = 0°
P = 11°
O = 10°

3. Tolerance Group	
Metric (mm)	
Length of edge	±0.025
G IC	±0.025
Thickness	±0.13
Length of edge	±0.08-0.15*
M IC	±0.05-0.10*
Thickness	±0.13
Length of edge	±0.013
F IC	±0.005
Thickness	±0.025
Length of edge	±0.13
C IC	±0.025
Thickness	±0.025
*Varies upon insert size	

4. Mounting Style	
T = One-sided countersunk	Cylindrical fixing hole Countersunk 40° - 60°
H = One-sided chipbreaker	Cylindrical fixing hole Countersunk 70° - 90°
W = Without chipbreaker	Cylindrical fixing hole Countersunk 40° - 60°
X = Special design	Special insert design
A = Without chipbreaker	Cylindrical fixing hole Without countersunk

5. Insert Size / Cutting Edge							
Metric (mm)	C	D	R	S	T	V	W
3.97 mm					006		03
5.00 mm					F20		
6.00 mm					F21		
6.35 mm	06				11	11	
7.94 mm				07			
9.52 mm	09	11		09	16	16	
10.00 mm		10					
12.00 mm	12	12					
12.70 mm	16	15		12			
15.87 mm			15	15			
16.00 mm			16				
19.05 mm		19		19			
20.00 mm			20				
25.00 mm			25				
25.40 mm				25			

6. Insert Thickness
Metric (mm)
01 = 1.59 mm
02 = 2.38 mm
T2 = 2.78 mm
03 = 3.18 mm
T3 = 3.97 mm
04 = 4.76 mm
05 = 5.56 mm
06 = 6.35 mm
07 = 7.94 mm

7. Corner Radius
Metric (mm)
005 = 0.05 mm
01 = 0.10 mm
02 = 0.20 mm
03 = 0.30 mm
04 = 0.40 mm
06 = 0.60 mm
08 = 0.80 mm
12 = 1.20 mm
16 = 1.60 mm
20 = 2.00 mm
24 = 2.40 mm

Wohlhaupter Insert Grades

Uncoated Carbide

Uncoated Carbide

Cutting Material	Description	Material	ISO Application							
			05	10	15	20	25	30	35	40
WHW01 (HW)	<ul style="list-style-type: none"> Fine-grain carbide Finishing & light roughing Non-ferrous metals, cast materials & difficult-to-machine alloys 	P								
		M								
		K								
		N								
		S								
		H								
WHW16 (HW)	<ul style="list-style-type: none"> Fine-grain carbide Finishing & light roughing Non-ferrous metals, cast materials & difficult-to-machine alloys 	P								
		M								
		K								
		N								
		S								
		H								
WHW20 (HW)	<ul style="list-style-type: none"> Tough fine-grain carbide Finishing, roughing & grooving Steel & cast materials, cast steel Non-ferrous materials & difficult-to-machine alloys 	P								
		M								
		K								
		N								
		S								
		H								

Wohlhaupter Insert Grades

Coated Carbide

Coated Carbide

Cutting Material	Description	Material	ISO Application							
			05	10	15	20	25	30	35	40
WHC05 (HC)	<ul style="list-style-type: none"> PVD coating with nano-composite structure Finishing & roughing Steels, stainless steels, cast materials, & difficult-to-machine alloys 	P								
		M								
		K								
		N								
		S								
		H								
WHC18 (HC)	<ul style="list-style-type: none"> PVD-TiB2 coating Finishing & light roughing Non-ferrous metals 	P								
		M								
		K								
		N								
		S								
		H								
WHC19 (HC)	<ul style="list-style-type: none"> Multilayer PVD coating Finishing & roughing Stainless steels 	P								
		M								
		K								
		N								
		S								
		H								
WHC20 (HC)	<ul style="list-style-type: none"> Multilayer CVD coating Finishing Steels & stainless steels 	P								
		M								
		K								
		N								
		S								
		H								
WHC30 (HC)	<ul style="list-style-type: none"> CVD coating Roughing Steel & cast steel 	P								
		M								
		K								
		N								
		S								
		H								
WHC79 (HC)	<ul style="list-style-type: none"> Multilayer MT CVD coating Roughing & finishing Steels, stainless steels & cast materials 	P								
		M								
		K								
		N								
		S								
		H								
WHC81 (HC)	<ul style="list-style-type: none"> Thick MT CVD coating with adominal AL203 High cutting speeds possible Excellent choice for cast materials 	P								
		M								
		K								
		N								
		S								
		H								
WHC88 (HC)	<ul style="list-style-type: none"> Multilayer PVD coating Finishing & roughing Universal usage 	P								
		M								
		K								
		N								
		S								
		H								

Wohlhaupter Insert Grades

Coated Carbide

Coated Carbide

Cutting Material	Description	Material	ISO Application							
			05	10	15	20	25	30	35	40
WHC98 (HC)	<ul style="list-style-type: none"> PVD TiAlN coating Roughing & finishing Steels, stainless steels & difficult-to-machine materials 	P								
		M								
		K								
		N								
		S								
		H								
WHC111 (HC)	<ul style="list-style-type: none"> PVD TiAlN coating Finishing Machining of steels after heat treating with high Cr content up to 60 HRC Hard - soft transitions, difficult-to-machine alloys & stainless steels 	P								
		M								
		K								
		N								
		S								
		H								
WHC114 (HC)	<ul style="list-style-type: none"> Multilayer PVD coating Finishing & roughing Steels, stainless steels, & difficult-to-machine materials 	P								
		M								
		K								
		N								
		S								
		H								
WHC136 (HC)	<ul style="list-style-type: none"> Stronger PVD coating with improved coating adhesion High oxidation resistance allows a wide range of applications 	P								
		M								
		K								
		N								
		S								
		H								
WHC164 (HC)	<ul style="list-style-type: none"> Thick MT-CVD coating with a dominant AC₂O₃ Primarily developed for the material groups P-K & alternatively H Full & discontinuous cut High cutting speeds possible 	P								
		M								
		K								
		N								
		S								
		H								
WHC168 (HC)	<ul style="list-style-type: none"> Multilayer MT CVD coating Excellent combination of toughness & reliability Steels, cast materials & alternatively for stainless steel 	P								
		M								
		K								
		N								
		S								
		H								
WHC170 (HC)	<ul style="list-style-type: none"> Multilayer MT CVD coating Excellent toughness First choice for strong interruptions Cast materials and steel 	P								
		M								
		K								
		N								
		S								
		H								
WHC198 (HC)	<ul style="list-style-type: none"> Upgraded PVD grade with hard AlTiN coating Optimized cutting edge stability General machining of steel, stainless steel, high-temperature resistant alloys, titanium, iron, cast iron, & non-ferrous materials 	P								
		M								
		K								
		N								
		S								
		H								
WHC190 (HC)	<ul style="list-style-type: none"> Newest generation multilayer PVD coating Finishing & roughing Extremely universal & the first choice for poor machining conditions Excellent in cast steels, stainless steels, & super alloys 	P								
		M								
		K								
		N								
		S								
		H								

Wohlhaupter Insert Grades

Uncoated Cermet | Coated Cermet

Uncoated Cermet

Cutting Material	Description	Material	ISO Application							
			05	10	15	20	25	30	35	40
WHT10 (HT)	<ul style="list-style-type: none"> Uncoated cermet Finishing Steels, stainless steels & cast materials 	P								
		M								
		K								
		N								
		S								
		H								
WHT12 (HC)	<ul style="list-style-type: none"> Uncoated cermet Finishing Steels, cast materials, sintered metals, & non-ferrous metals 	P								
		M								
		K								
		N								
		S								
		H								
WHT32 (HC)	<ul style="list-style-type: none"> Uncoated cermet Finishing Steels & cast materials 	P								
		M								
		K								
		N								
		S								
		H								

Coated Cermet

Cutting Material	Description	Material	ISO Application							
			05	10	15	20	25	30	35	40
WTC15 (TC)	<ul style="list-style-type: none"> New PVD brilliant coating Reduce friction coefficient in turning applications Coated cermet general purpose grade for material group Achieves excellent surface finish with excellent wear resistance Usable in stainless steels 	P								
		M								
		K								
		N								
		S								
		H								
WTC121 (TC)	<ul style="list-style-type: none"> PVD coated cermet Finishing of steels & stainless steels 	P								
		M								
		K								
		N								
		S								
		H								

Wohlhaupter Insert Grades

Uncoated Cubic Boron Nitride | Coated Cubic Boron Nitride

Uncoated Cubic Boron Nitride

Cutting Material	Description	Material	ISO Application							
			05	10	15	20	25	30	35	40
WBN150 (BN)	<ul style="list-style-type: none"> Uncoated CBN grade Roughing & finishing smooth & slightly discontinuous cuts Hardened steels 52 - 64 HRC Grain size 2 µm CBN content: 50% 	P								
		M								
		K								
		N								
		S								
		H								
WBN200 (BN)	<ul style="list-style-type: none"> Uncoated CBN grade Roughing & finishing highly discontinuous cuts Hardened steels 52 - 64 HRC Grain size 3 µm CBN content: 65% 	P								
		M								
		K								
		N								
		S								
		H								
WBN300 (BN)	<ul style="list-style-type: none"> Uncoated CBN grade Roughing & finishing smooth cuts Hardened steels 52 - 64 HRC Grain size 0.5 - 1.0 µm CBN content: approximately 50% 	P								
		M								
		K								
		N								
		S								
		H								
WBN450 (BN)	<ul style="list-style-type: none"> Uncoated CBN grade Roughing & finishing smooth & discontinuous cuts Pearlite grey cast iron & sintered metals Grain size 2 µm CBN content: 90% 	P								
		M								
		K								
		N								
		S								
		H								
WBN448 (BN)	<ul style="list-style-type: none"> Uncoated CBN grade Roughing & finishing smooth & discontinuous cuts Pearlite grey cast iron & sintered metals and ductile iron CBN content: 90% 	P								
		M								
		K								
		N								
		S								
		H								

Coated Cubic Boron Nitride

Cutting Material	Description	Material	ISO Application							
			05	10	15	20	25	30	35	40
WBC300 (BC)	<ul style="list-style-type: none"> Coated CBN Roughing and finishing smooth cuts Hardened steels 52 - 64 HRC Grain size 1 µm CBN content: 50% 	P								
		M								
		K								
		N								
		S								
		H								

Wohlhaupter Insert Grades

Polycrystalline Diamond | Ceramic Cutting Material

Polycrystalline Diamond

Cutting Material	Description	Material	ISO Application							
			05	10	15	20	25	30	35	40
PCD D30 (DP)	<ul style="list-style-type: none"> PCD medium grain grade Finishing Al alloys & Mg alloys up to 12% Si Grain size 10 µm 	P								
		M								
		K								
		N								
		S								
		H								
PCD D50 (DP)	<ul style="list-style-type: none"> PCD mixed-grain grade Finishing CFRP, GRP, MMC, Al alloys over 12% Si Grain size 2 - 30 µm 	P								
		M								
		K								
		N								
		S								
		H								











Ceramic Cutting Material

Cutting Material	Description	Material	ISO Application							
			05	10	15	20	25	30	35	40
WCN06 (CN)	<ul style="list-style-type: none"> Uncoated silicon-nitride ceramic Roughing Pearlite grey cast iron 	P								
		M								
		K								
		N								
		S								
		H								

Wohlhaupter Insert Geometries

Cermet | Carbide





Cermet | Carbide

Geometry	Description	Application	Available Form
108 	<ul style="list-style-type: none"> Sintered chip breaker for higher feeds Suitable for highly discontinuous cuts 	▼▼▼ ▼	F101, F103, F104, F112, F113
109 	<ul style="list-style-type: none"> Sintered geometry with V-shaped chip breaker for roughing & finishing Good chip control even for shallow depth of cut 	▼▼▼ ▼	F101, F103, F104
112 	<ul style="list-style-type: none"> Sintered chip breaker Finishing & light roughing 	▼▼▼ ▼	F101, F103
121 	<ul style="list-style-type: none"> Positive geometry with stable cutting edge Finishing in different material groups Good chip control 	▼▼▼	F20, F211
122 	<ul style="list-style-type: none"> Sintered chip breaker Good chip control - even with long-chipping materials 	▼▼▼	F101, F103, F161
126 	<ul style="list-style-type: none"> Sintered version with a wide range of applications 	▼	F105
127 	<ul style="list-style-type: none"> Highly positive sintered geometry For non-ferrous metals & cast iron 	▼▼▼ ▼	F37, F39, F101, F103, F104, F112, F113
128 	<ul style="list-style-type: none"> Highly positive sintered geometry Polished for finishing non-ferrous metals, cast iron, & steel 	▼▼▼	F20
129 	<ul style="list-style-type: none"> Highly positive chip breaking geometry Polished for non-ferrous metals, cast iron, & steel Ideal for structural steel applications 	▼▼▼ ▼	F37, F39, F101, F103
145 	<ul style="list-style-type: none"> Geometry for finishing in smooth & discontinuous cut Good chip control - even with long-chipping materials 	▼▼▼ ▼	F101, F103, F112, F113, F161
146 	<ul style="list-style-type: none"> Positive geometry with stable cutting edge Universal usage for roughing, finishing and chamfering 	▼▼▼ ▼	F037, F039, F101, F103, F104, F112, F113,

Wohlhaupter Insert Geometries

Cermet | Carbide



Cermet | Carbide

Geometry	Description	Application	Available Form
155 	<ul style="list-style-type: none"> Positive sintered geometry Special cutting edge design in combination with the chip breaker design enables exceptional chip control even at shallow cutting depths & light feeds 	▼▼▼	F20, F101, F103, F39
158 	<ul style="list-style-type: none"> Stable sintered geometry for roughing & finishing with & without discontinuous cuts 	▼▼▼ ▼	F101, F103, F104, F105, F113, F114, F163
174W 	<ul style="list-style-type: none"> Wiper geometry for highly productive turning & boring Can be used with pitch angle 92° - 95° Good chip breaking properties even at lower feed rates 	▼▼▼ ▼	F101, F103
192 	<ul style="list-style-type: none"> Sintered version for a variety of applications Low cutting pressure because of sharp cutting edge prep 	▼▼▼ ▼	F39, F101, F103, F104, F112, F113, F163, F161, F262, F264
199 	<ul style="list-style-type: none"> Positive sintered geometry for wide variety of applications Special chip breaker allows chip control with different radial depth of cut 	▼▼▼ ▼	F101, F103, F104, F112, F113
200 	<ul style="list-style-type: none"> Highly positive sintered geometry Applicable for various material groups for low cutting pressure 	▼▼▼ ▼	F39, F101, F103, F104, F264
650 	<ul style="list-style-type: none"> Obliquely ground chip breaker reduces cutting forces Finishing & smooth interrupted cuts 	▼▼▼	F20, F211
711 	<ul style="list-style-type: none"> Negative geometry with 0 rake suitable for fine finishing and semi roughing Machined materials in groups K & H Continuous and moderately interrupted cut 	▼▼▼ ▼	F101, F103, F104, F113, F163
840 	<ul style="list-style-type: none"> Parallel ground chip breaker For finish operations with stable cutting edge 	▼▼▼	F20
850 	<ul style="list-style-type: none"> Parallel ground chip breaker Good chip control with short to medium feeds 	▼▼▼	F161
860 	<ul style="list-style-type: none"> Parallel ground chip breaker reduces cutting forces Stable for a wide range of applications 	▼▼▼ ▼	F101, F103, F104, F105, F325

Wohlhaupter Insert Geometries

Tangential | Ceramic

Tangential

Geometry	Description	Application	Available Form
880 	<ul style="list-style-type: none"> Large parallel ground chip breaker with 10° rake angle for reduced cutting force 	▼	F04, F05
811 	<ul style="list-style-type: none"> Smooth geometry without additional ground chip breaker Reinforced cutting edges provide stability Excellent for cast materials 	▼	F05



Ceramic

Geometry	Description	Application	Available Form
711 	<ul style="list-style-type: none"> Smooth geometry with 0° rake angle High cutting edge stability particularly in discontinuous cuts 	▼	F75, F103, F104, F123







Wohlhaupter Insert Geometries

PCD | CBN

PCD

Geometry	Description	Application	Available Form
720 	<ul style="list-style-type: none"> Smooth geometry in positive version with 7° rake angle for PCD Sharp cutting edge 	▼▼▼	F20, F101, F103
730 	<ul style="list-style-type: none"> Smooth geometry with 0° rake angle for PCD Sharp cutting edge 	▼▼▼	F20, F39, F75, F101, F103, F123, F211, F262, F264
735 	<ul style="list-style-type: none"> Smooth geometry Laser-cut chip breaker for PCD Suitable for long-chipping aluminium wrought alloys 	▼▼▼	F20, F39, F101, F103, F211, F262, F264

CBN

Geometry	Description	Diagram			Application	Available Form
		R	Fb	Fw		
741 	<ul style="list-style-type: none"> Smooth geometry with 0° rake angle for CBN Rounded cutting edge with 30° chamfer 	0.015	0.15	30°	▼▼▼	F20, F101, F103
742 	<ul style="list-style-type: none"> Smooth geometry with 0° rake angle for CBN Rounded cutting edge with 15° chamfer 	0.015	0.1	15°	▼▼▼	F20, F101, F103
745 	<ul style="list-style-type: none"> Smooth geometry with 0° rake angle for CBN Rounded cutting edge with 30° chamfer 	0.015	0.05	30°	▼▼▼	F20, F211
747 	<ul style="list-style-type: none"> Smooth geometry with 0° rake angle for CBN Rounded cutting edge with a small 20° chamfer 	0.015	0.1	20°	▼▼▼	F39, F104, F262, F264
748 	<ul style="list-style-type: none"> Smooth geometry with 0° rake angle for CBN Rounded cutting edge No chamfer 	0.015	0.2	20°	▼▼▼	F20, F101, F103, F211
749 	<ul style="list-style-type: none"> Smooth geometry with 0° rake angle for CBN Rounded cutting edge with a large 20° chamfer 	0.015	0.2	20°	▼▼▼ ▼	F75, F123, F264
768 	<ul style="list-style-type: none"> Smooth geometry with 7° rake angle for CBN Rounded cutting edge 	0.015	-	-	▼▼▼	F20, F101, F103

Insert Form 211

Cermet | Carbide



121 Geometry

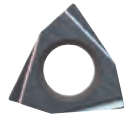

650 Geometry

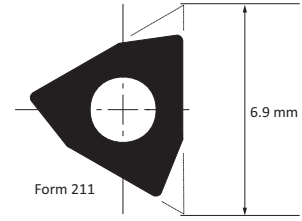

						Cermet					Carbide										
						Uncoated			Coated		Uncoated		Coated								
						WHT10	WHT12	WHT32	WTC15	WTC121	WHW01	WHW16	WHC05	WHC18	WHC19	WHC79	WHC98	WHC111	WHC114	WHC136	WHC164
Steel	P	▼▼▼											▼▼▼	▼▼▼			▼▼▼	▼▼▼			
Stainless Steel	M												▼▼▼	▼▼▼			▼▼▼	▼▼▼			
Cast Iron	K	▼▼▼											▼▼▼	▼▼▼			▼▼▼	▼▼▼			
Non-Ferrous Materials	N	▼▼▼											▼▼▼	▼▼▼							
Titanium	S												▼▼▼	▼▼▼							
Hard Materials	H																	▼▼▼			
Geometry	Radius		Description	ISO Code	Part No.	WHT10	WHT12	WHT32	WTC15	WTC121	WHW01	WHW16	WHC05	WHC18	WHC19	WHC79	WHC98	WHC111	WHC114	WHC136	WHC164
121	0.10	0.004	F21101GN121	WBGX030101	397675										⚙			⚙			
121	0.20	0.008	F21102GN121	WBGX030102	397676										⚙			⚙			
650	0.10	0.004	F21101GL650	WBGX030101	097755		●				●		●	●							●
650	0.20	0.008	F21102GL650	WBGX030102	097454		●				●		●								●

Reference Key

Symbol	Machining Conditions
●	Good - Main Application
⚙	Average - Main Application
⚙	Difficult - Main Application

Reference Key

Symbol	Insert Type
▼▼▼	Finishing - Main Application
▼▼▼	Finishing - Extended Application

Insert Form	Countersunk Screw		Torque Driver	Service Key	Technical Data	
211	215377	M2 x 0.4 x 4	415507	115537	Torque	Key Size
					0.6 Nm	T6

Insert Form 211

CBN | PCD

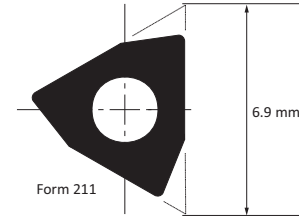
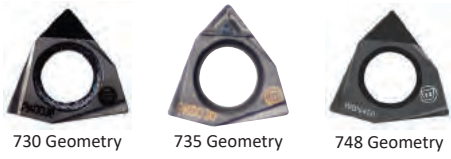

						Ceramic		CBN				PCD			
						Uncoated	Coated	Uncoated		Coated					
Steel						P									
Stainless Steel						M									
Cast Iron						K			▼▼▼						
Non-Ferrous Materials						N						▼▼▼	▼▼▼		
Titanium						S									
Hard Materials						H			▼▼▼						
Geometry	Radius		Description	ISO Code	Part No.			WBN150	WBN200	WBN300	WBN450			PKDD30	PKDD50
	mm	in													
730	0.10	0.004	F21101GN730	WBGX030101	397763									●	
730	0.20	0.008	F21102GN730	WBGX030102	097557									●	●
735	0.20	0.008	F21102GN735	WBGX030102	397237									●	
748	0.10	0.004	F21101GN748	WBGX030101	097486			●			●				●
748	0.20	0.008	F21102GN748	WBGX030102	097552			●			●				

Reference Key

Symbol	Machining Conditions
●	Average - Main Application

Reference Key

Symbol	Insert Type
▼▼▼	Finishing - Main Application

Insert Form	Countersunk Screw		Torque Driver	Service Key	Technical Data	
					Torque	Key Size
211	215377	M2 x 0.4 x 4	415507	115537	0.6 Nm	T6

Insert Form 20

Cermet | Carbide

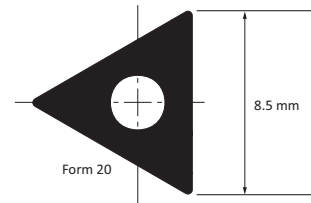

						Cermet					Carbide									
						Uncoated		Coated			Uncoated		Coated							
						WHT10	WHT12	WHT32	WTC15	WTC121	WHW01	WHW16	WHC05	WHC18	WHC19	WHC79	WHC98	WHC111	WHC114	WHC136
Geometry	Radius		Description	ISO Code	Part No.															
	mm	in																		
Steel	P					▼▼	▼▼	▼▼	▼▼	▼▼	▼▼	▼▼	▼▼	▼▼	▼▼	▼▼	▼▼	▼▼	▼▼	▼▼
Stainless Steel	M							▼▼	▼▼			▼▼	▼▼					▼▼	▼▼	
Cast Iron	K					▼▼	▼▼	▼▼	▼▼	▼▼	▼▼	▼▼	▼▼	▼▼	▼▼	▼▼	▼▼	▼▼	▼▼	▼▼
Non-Ferrous Materials	N					▼▼	▼▼	▼▼	▼▼	▼▼	▼▼	▼▼	▼▼	▼▼	▼▼	▼▼	▼▼	▼▼	▼▼	▼▼
Titanium	S									▼▼	▼▼			▼▼	▼▼	▼▼	▼▼	▼▼	▼▼	
Hard Materials	H																	▼▼	▼▼	
121	0.10	0.004	F02001GN121	TOGX080201	397672										●			●		
121	0.20	0.008	F02002GN121	TOGX080202	397673										●			●		
121	0.40	0.016	F02004GN121	TOGX080204	397674										●			●		
121W	0.20	0.008	F02002GX121W	TOGX080202	397916										●			●		
121W	0.40	0.016	F02004GX121W	TOGX080204	397917										●			●		
128	0.10	0.004	F02001GN128	TOGX080201	297473						●	●								
128	0.20	0.008	F02002GN128	TOGX080202	297541						●	●	●							
128	0.40	0.016	F02004GN128	TOGX080204	297542						●	●	●							
155	0.20	0.008	F02002MN155	TOMX080202	397688				●											
155	0.40	0.016	F02004MN155	TOMX080204	397689				●											
650	0.10	0.004	F02001GL650	TOGX080201	097153		●			●		●								●
650	0.20	0.008	F02002GL650	TOGX080202	097546		●			●		●								●
650	0.30	0.012	F02003GL650	TOGX080203	097154					●		●								●
650	0.40	0.016	F02004GL650	TOGX080204	097599		●			●		●								●
650	0.80	0.031	F02008GL650	TOGX080208	397764					●										●
840	0.20	0.008	F02002GR840	TOGX080202	097701		●					●								

Reference Key

Symbol	Machining Conditions
●	Good - Main Application
●	Average - Main Application
⚙	Difficult - Main Application

Reference Key

Symbol	Insert Type
▼▼	Finishing - Main Application
▼▼	Finishing - Extended Application

				Technical Data	
Insert Form	Countersunk Screw	Torque Driver	Service Key	Torque	Key Size
20	115535 M2 x 0.4 x 5	415508	115591	0.9 Nm	T7

Insert Form 20

CBN | PCD

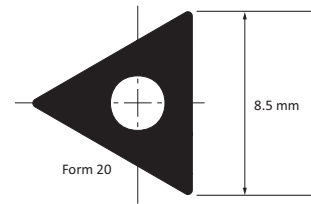
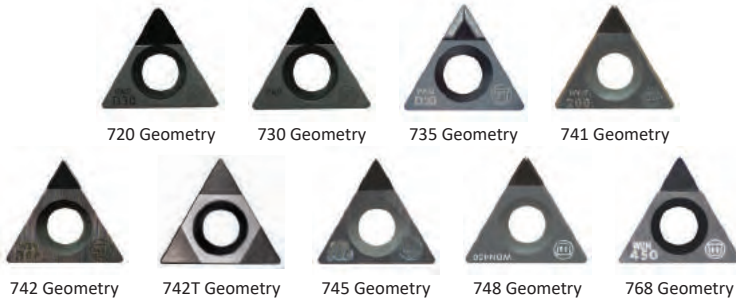





						CBN					PCD		
						Uncoated			Coated				
Steel													
Stainless Steel													
Cast Iron							▼▼▼	▼▼▼	▼▼▼				
Non-Ferrous Materials											▼▼▼	▼▼▼	
Titanium													
Hard Materials							▼▼▼	▼▼▼			▼▼▼		
Geometry	Radius		Description	ISO Code	Part No.	WBN150	WBN200	WBN300	WBN450	WBN448	WBC300	PKDD30	PKDD50
	mm	in											
720	0.20	0.008	F02002GN720	TOGX080202	297692							●	
720	0.40	0.016	F02004GN720	TOGX080204	297845							●	
730	0.20	0.008	F02002GN730	TOGX080202	097487							●	●
730	0.40	0.016	F02004GN730	TOGX080204	097686							●	●
730	0.80	0.031	F02008GN730	TOGX080208	097877							●	
735	0.20	0.008	F02002GN735	TOGX080202	397133							●	
735	0.40	0.016	F02004GN735	TOGX080204	397301							●	
741	0.20	0.008	F02002GN741	TOGX080202	297260		●						
741	0.40	0.016	F02004GN741	TOGX080204	297262		●						
742	0.20	0.008	F02002GN742	TOGX080202	297264			●					
742	0.40	0.016	F02004GN742	TOGX080204	397610			●					
742T	0.20	0.008	F02002GN742T	TOGX080202	397961					●	●		
742T	0.40	0.016	F02004GN742T	TOGX080204	397551					●	●		
745	0.10	0.004	F02001GN745	TOGX080201	297259		●						
748	0.20	0.008	F02002GN748	TOGX080202	297780				●				
748	0.40	0.016	F02004GN748	TOGX080204	297782				●				
768	0.20	0.008	F02002GN768	TOGX080202	397146				●				
768	0.40	0.016	F02004GN768	TOGX080204	397192				●				

Reference Key

Symbol	Machining Conditions
●	Good - Main Application
●	Average - Main Application

Reference Key

Symbol	Insert Type
▼▼▼	Finishing - Main Application

				Technical Data		
Insert Form	Countersunk Screw	Torque Driver	Service Key	Torque	Key Size	
20	115535 M2 x 0.4 x 5	415508	115591	0.9 Nm	T7	

Insert Forms 161, 163

Cermet | Carbide

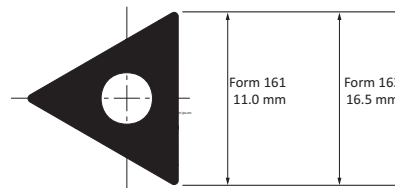

						Cermet					Carbide											
						Uncoated		Coated			Uncoated		Coated									
Steel						▼▼▼		▼▼▼			▼▼▼		▼▼▼									
Stainless Steel						▼▼▼		▼▼▼			▼▼▼		▼▼▼									
Cast Iron						▼▼▼		▼▼▼			▼▼▼		▼▼▼									
Non-Ferrous Materials						▼▼▼		▼▼▼			▼▼▼		▼▼▼									
Titanium						▼▼▼		▼▼▼			▼▼▼		▼▼▼									
Hard Materials						▼▼▼		▼▼▼			▼▼▼		▼▼▼									
Geometry	Radius		Description	ISO Code	Part No.	WHT10	WHT12	WHT32	WTC15	WTC121	WHW01	WHW16	WHC05	WHC81	WHC88	WHC190	WHC79	WHC111	WHC114	WHC136	WHC164	
	mm	in				WHT10	WHT12	WHT32	WTC15	WTC121	WHW01	WHW16	WHC05	WHC81	WHC88	WHC190	WHC79	WHC111	WHC114	WHC136	WHC164	
122	0.40	0.016	F16104MN122	TCMT110204	097953	●																
129	0.20	0.008	F16102GN129	TCGT110202	397769						●	●										
129	0.40	0.016	F16104GN129	TCGT110204	397770						●	●										
129	0.40	0.016	F16304GN129	TCGT16T304	397771						●	●										
145	0.40	0.016	F16104GN145	TCGT110204	297993												●					
146	0.40	0.016	F16104MN146	TCMT110204	397977								●	●	●							
146	0.80	0.031	F16108MN146	TCMT110208	397026								●	●	●							
146	0.40	0.016	F16304MN146	TCMT16T304	397990								●	●	●							
146	0.80	0.031	F16308MN146	TCMT16T308	397974								●	●	●							
158	0.40	0.016	F16304MN158	TCMT16T304	297604												●					
192	0.40	0.016	F16104MN192	TCMT110204	397663										●							●
192	0.40	0.016	F16304MN192	TCMT16T304	397654										●							●
192	0.80	0.031	F16308MN192	TCMT16T308	397772										●							●
711	0.40	0.016	F16304MN711	TCMT16T304	397898								●									
711	0.80	0.031	F16304MN711	TCMT16T308	397899								●									
850	0.20	0.008	F16102GL850	TCGT110202	097512		●															

Reference Key

Symbol	Machining Conditions
●	Good - Main Application
◐	Average - Main Application
⚙	Difficult - Main Application

Reference Key

Symbol	Insert Type
▼▼▼	Finishing - Main Application
▽▽▽	Finishing - Extended Application

Insert Form	Countersunk Screw		Torque Driver	Service Key	Technical Data	
	Part No.	Dimensions			Torque	Key Size
161	115676	M2.5 x 0.45 x 5	415514	115590	1.2 Nm	T8
163	115673	M3.5 x 0.6 x 9	415510	115664	3.0 Nm	T15

Insert Form 47

Cermet | Carbide



650 Geometry

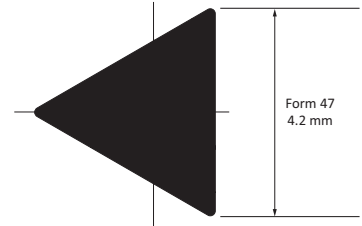

						Carbide									
						Uncoated				Coated					
Material						WHW01	WHW16	WHC05	WHC18	WHC20	WHC79	WHC111	WHC114	WHC136	WHC164
Steel	P									▽▽▽					
Stainless Steel	M									▽▽▽					
Cast Iron	K					▽▽▽				▽▽▽					
Non-Ferrous Materials	N					▽▽▽									
Titanium	S					▽▽▽									
Hard Materials	H														
Geometry	Radius		Description	ISO Code	Part No.	WHW01	WHW16	WHC05	WHC18	WHC20	WHC79	WHC111	WHC114	WHC136	WHC164
	mm	in													
650	0.10	0.004	F04701FL650	TOFX040101	097832	●				●					
650	0.20	0.008	F04702FL650	TOFX040102	097833	●				●					

Reference Key

Symbol	Machining Conditions
●	Good - Main Application

Reference Key

Symbol	Insert Type
▽▽▽	Finishing - Main Application
▽▽	Finishing - Extended Application

Insert Form	Countersunk Screw	Clamping Jaw	Torque Driver	Service Key	Technical Data	
					Torque	Key Size
47	315324 M1.8 x 0.35 x 4	315323	-	115537	0.5 Nm	T6

Insert Forms 101, 103, 104, 105

Cermet | Carbide



						Cermet						Carbide															
						Uncoated			Coated			Uncoated			Coated												
						WHT10	WHT12	WHT16	WHT32	WTC15	WTC121	WHW01	WHW16	WHC05	WHC18	WHC19	WHC79	WHC98	WHC111	WHC114	WHC136	WHC164					
Geometry	Radius		Description	ISO Description	Part No.																						
	mm	in																									
Steel	P																										
Stainless Steel	M																										
Cast Iron	K																										
Non-Ferrous Materials	N																										
Titanium	S																										
Hard Materials	H																										
108	0.20	0.008	F10102MN108	CCMT060202	297833																						
108	0.40	0.016	F10104MN108	CCMT060204	297537																						
108	0.40	0.016	F10304MN108	CCMT09T304	297891																						
108	0.80	0.031	F10308MN108	CCMT09T308	397118																						
108	0.40	0.016	F10404MN108	CCMT120404	297725																						
108	0.80	0.031	F10408MN108	CCMT120408	297724																						
109	0.20	0.008	F10102MN109	CCMT060202	397352																						
109	0.40	0.016	F10104MN109	CCMT060204	397765																						
109	0.40	0.016	F10304MN109	CCMT09T304	397354																						
109	0.80	0.031	F10308MN109	CCMT09T308	397355																						
109	0.40	0.016	F10404MN109	CCMT120404	397356																						
109	0.80	0.031	F10408MN109	CCMT120408	397357																						
112	0.20	0.008	F10102GN112	CCGT060202	297485																						
112	0.40	0.016	F10104MN112	CCMT060204	297434																						
112	0.20	0.008	F10302GN112	CCGT09T302	297534																						
112	0.40	0.016	F10304MN112	CCMT09T304	297387																						
122	0.20	0.008	F10102MN122	CCMT060202	097899																						
122	0.40	0.016	F10104MN122	CCMT060204	097926																						
122	0.20	0.008	F10302MN122	CCMT09T302	097862																						
122	0.40	0.016	F10304MN122	CCMT09T304	097957																						
126	0.80	0.031	F10508MN126	CCMT160508	297557																						
126	1.20	0.047	F10512MN126	CCMT160512	297558																						
127	0.20	0.008	F10102GN127	CCGT060202	097529																						
127	0.40	0.016	F10104GN127	CCGT060204	097445																						
127	0.20	0.008	F10302GN127	CCGT09T302	297550																						
127	0.40	0.016	F10304GN127	CCGT09T304	097497																						
127	0.40	0.016	F10404GN127	CCGT120404	097496																						

Reference Key

Symbol	Machining Conditions
●	Good - Main Application
◐	Average - Main Application

Reference Key

Symbol	Insert Type
▼	Roughing - Main Application
▽	Roughing - Extended Application
▼▼	Finishing - Main Application
▽▽	Finishing - Extended Application

Insert Form	Countersunk Screw		Torque Driver		Service Key		Technical Data	
	Torque	Key Size	Torque	Key Size	Torque	Key Size	Torque	Key Size
101	115676	M2.5 x 0.45 x 5	415514	115590	1.2 Nm	T8		
103	115672 ($\phi 37\text{ mm}$)	M3.5 x 0.6 x 7.5	415510	115664	3.0 Nm	T15		
103	115673 (>math>\phi 36\text{ mm}</math>)	M3.5 x 0.6 x 9	415510	115664	3.0 Nm	T15		
104	215149	M4.5 x 0.75 x 11.5	415543	215150	5.0 Nm	T20		
105	215149	M4.5 x 0.75 x 11.5	415543	215150	5.0 Nm	T20		

Insert Forms 101, 103, 104

Cermet | Carbide

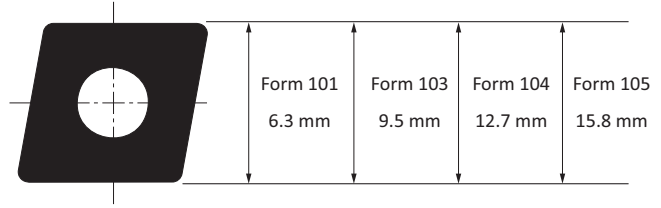
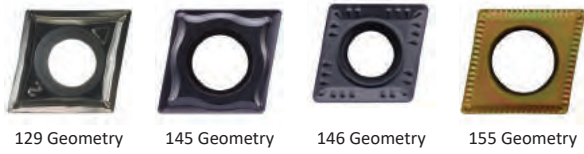

					Cermet				Carbide													
					Uncoated		Coated		Uncoated		Coated											
Material	ISO	Part No.	Radius	Description	WHT10	WHT32	WTC15	WTC121	WHW01	WHW16	WHC05	WHC18	WHC19	WHC79	WHC81	WHC88	WHC98	WHC111	WHC114	WHC136	WHC164	
Steel	P						▼▼▼			▼					▼▼▼	▼▼▼		▼▼▼				
Stainless Steel	M						▼▼▼			▼					▼▼▼	▼▼▼		▼▼▼				
Cast Iron	K						▼▼▼			▼					▼▼▼	▼▼▼		▼▼▼				
Non-Ferrous Materials	N									▼		▼										
Titanium	S									▼	▼					▼▼▼	▼		▼▼▼			
Hard Materials	H														▼▼▼			▼▼▼				
Geometry	mm	in	Description	ISO Description	Part No.																	
129	0.05	0.002	F101005GN129	CCGT0602005	397738					●	●											
129	0.10	0.004	F10101GN129	CCGT060201	397737					●	●											
129	0.20	0.008	F10102GN129	CCGT060202	297545					●	●	●										
129	0.40	0.016	F10104GN129	CCGT060204	297546					●	●	●										
129	0.20	0.008	F10302GN129	CCGT09T302	297547					●	●	●										
129	0.40	0.016	F10304GN129	CCGT09T304	297548					●	●	●										
145	0.40	0.016	F10104GN145	CCGT060204	297980													●				
145	0.80	0.031	F10108GN145	CCGT060208	397742													●				
145	0.40	0.016	F10304GN145	CCGT09T304	297994													●				
145	0.80	0.031	F10308GN145	CCGT09T308	297995													●				
146	0.40	0.016	F10104MN146	CCMT060204	397953										●	●						
146	0.40	0.016	F10304MN146	CCMT09T304	397142										●	●						
146	0.80	0.031	F10308MN146	CCMT09T308	397946										●	●						
146	0.40	0.016	F10404MN146	CCMT120404	397469											●	●					
146	0.80	0.031	F10408MN146	CCMT120408	397143										●	●						
146	1.20	0.047	F10412MN146	CCMT120412	397939											●	●					
155	0.20	0.008	F10102MN155	CCMT060202	397662			●														
155	0.40	0.016	F10104MN155	CCMT060204	397739			●														
155	0.40	0.016	F10304MN155	CCMT09T304	397740			●														

Insert Form	Countersunk Screw		Torque Driver		Service Key		Technical Data	
	Torque	Key Size	Torque	Key Size	Torque	Key Size	Torque	Key Size
101	115676	M2.5 x 0.45 x 5	415514	115590	1.2 Nm	T8		
103	115672 ($\leq \varnothing 37 \text{ mm}$)	M3.5 x 0.6 x 7.5	415510	115664	3.0 Nm	T15		
103	115673 (>math>\varnothing 36 \text{ mm}</math>)	M3.5 x 0.6 x 9	415510	115664	3.0 Nm	T15		
104	215149	M4.5 x 0.75 x 11.5	415543	215150	5.0 Nm	T20		
105	215149	M4.5 x 0.75 x 11.5	415543	215150	5.0 Nm	T20		

Reference Key

Symbol	Machining Conditions
●	Good - Main Application
●	Average - Main Application

Reference Key

Symbol	Insert Type
▼	Roughing - Main Application
▽	Roughing - Extended Application
▼▼▼	Finishing - Main Application
▽▽▽	Finishing - Extended Application

Insert Forms 101, 103, 104

Carbide

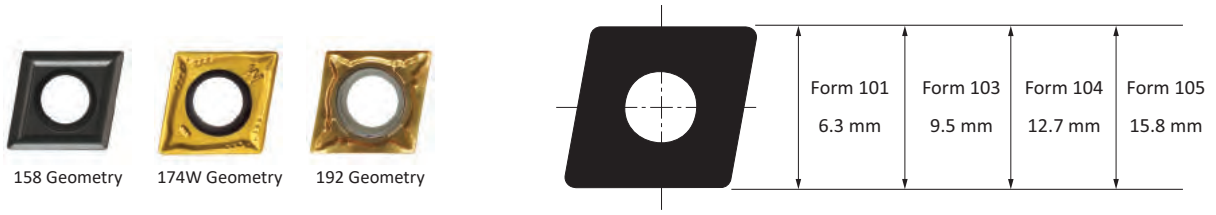

						Carbide										
						Uncoated					Coated					
						WHW01	WHW16	WHC05	WHC18	WHC19	WHC79	WHC98	WHC111	WHC114	WHC136	WHC164
Steel	P							▽▽▽		▽▽▽	▽▽▽		▽▽▽			▽▽▽
Stainless Steel	M							▽▽▽		▽▽▽	▽▽▽		▽▽▽			
Cast Iron	K							▽▽▽		▽▽▽	▽▽▽		▽▽▽			▽▽▽
Non-Ferrous Materials	N															
Titanium	S									▽▽▽			▽▽▽			
Hard Materials	H												▽▽▽			▽▽▽
Geometry	Radius		Description	ISO Code	Part No.	WHW01	WHW16	WHC05	WHC18	WHC19	WHC79	WHC98	WHC111	WHC114	WHC136	WHC164
158	0.20	0.008	F10102MN158	CCMT060202	297248						●		●			
158	0.40	0.016	F10104MN158	CCMT060204	297377						●		●			
158	0.40	0.016	F10304MN158	CCMT09T304	297239						●		●			
158	0.80	0.031	F10308MN158	CCMT09T308	297240						●		●			
158	0.40	0.016	F10404MN158	CCMT120404	297242						●		●			
158	0.80	0.031	F10408MN158	CCMT120408	297241						●		●			
158	0.80	0.031	F10508MN158	CCMT160508	297559			●			●		●			
158	1.20	0.047	F10512MN158	CCMT160512	297560						●		●			
174W	0.40	0.016	F10104MN174W	CCMT060204	397766					⚙						●
174W	0.40	0.016	F10304MN174W	CCMT09T304	397767					⚙						●
174W	0.80	0.031	F10308MN174W	CCMT09T308	397768					⚙						●
192	0.20	0.008	F10102MN192	CCMT060202	297531					⚙						●
192	0.40	0.016	F10104MN192	CCMT060204	297658					⚙						●
192	0.80	0.031	F10108MN192	CCMT060208	297588					⚙						●
192	0.20	0.008	F10302MN192	CCMT09T302	297958					⚙						●
192	0.40	0.016	F10304MN192	CCMT09T304	297653					⚙						●
192	0.80	0.031	F10308MN192	CCMT09T308	397614					⚙						●
192	0.40	0.016	F10404MN192	CCMT120404	397666					⚙						●
192	0.80	0.031	F10408MN192	CCMT120408	297878					⚙						●
192	1.20	0.047	F10412MN192	CCMT120412	397632					⚙						●

Reference Key

Symbol	Machining Conditions
●	Good - Main Application
●	Average - Main Application
⚙	Difficult - Main Application

Reference Key

Symbol	Insert Type
▽	Roughing - Main Application
▽	Roughing - Extended Application
▽▽▽	Finishing - Main Application
▽▽▽	Finishing - Extended Application

Insert Form	Countersunk Screw		Torque Driver		Service Key		Technical Data	
	Torque	Key Size	Torque	Key Size	Torque	Key Size	Torque	Key Size
101	115676	M2.5 x 0.45 x 5	415514	115590	1.2 Nm	T8		
103	115672 (\varnothing37 mm)	M3.5 x 0.6 x 7.5	415510	115664	3.0 Nm	T15		
103	115673 (>math>\varnothing</math>36 mm)	M3.5 x 0.6 x 9	415510	115664	3.0 Nm	T15		
104	215149	M4.5 x 0.75 x 11.5	415543	215150	5.0 Nm	T20		
105	215149	M4.5 x 0.75 x 11.5	415543	215150	5.0 Nm	T20		

Insert Forms 101, 103, 104

Cermet | Carbide



						Cermet						Carbide												
						Uncoated			Coated			Uncoated			Coated									
Geometry	Radius		Description	ISO Code	Part No.	WHT10	WHT12	WHT16	WHT32	WTC15	WTC121	WHW01	WHW16	WHC05	WHC18	WHC19	WHC77	WHC79	WHC98	WHC111	WHC114	WHC136	WHC164	
Steel	P											▼▼▼		▼▼▼			▼▼▼			▼▼▼	▼▼▼	▼▼▼	▼▼▼	▼▼▼
Stainless Steel	M										▽▽▽		▽▽▽								▽▽▽	▽▽▽	▽▽▽	▽▽▽
Cast Iron	K										▽	▽	▼▼▼	▼▼▼	▼▼▼	▼▼▼	▼▼▼	▼▼▼	▼▼▼	▼▼▼	▼▼▼	▼▼▼	▼▼▼	▼▼▼
Non-Ferrous Materials	N										▼▼▼													
Titanium	S																				▼▼▼	▼▼▼	▼▼▼	▼▼▼
Hard Materials	H																	▽▽▽		▼▼▼	▼▼▼	▼▼▼	▼▼▼	▼▼▼
199	0.20	0.008	F10102MN199	CCMT060202	397164																			●
199	0.40	0.016	F10104MN199	CCMT060204	397165																			●
199	0.20	0.008	F10302MN199	CCMT09T302	397702																			●
199	0.40	0.016	F10304MN199	CCMT09T304	397166																			●
199	0.80	0.031	F10308MN199	CCMT09T308	397167																			●
199	0.40	0.016	F10404MN199	CCMT120404	397191																			●
199	0.80	0.031	F10408MN199	CCMT120408	397168																			●
200	0.20	0.008	F10102GN200	CCGT060202	397585																			●
200	0.40	0.016	F10104GN200	CCGT060204	397586																			●
200	0.20	0.008	F10302GN200	CCGT09T302	397587																			●
200	0.40	0.016	F10304GN200	CCGT09T304	397588																			●
200	0.40	0.016	F10404GN200	CCGT120404	397589																			●
711	0.40	0.016	F10104MN711	CCMT060204	097637													●						
711	0.40	0.016	F10304MN711	CCMT09T304	097629													●						
711	0.80	0.031	F10308MN711	CCMT09T308	297910													●						
711	0.80	0.031	F10408MN711	CCMT120408	297911													●						
860	0.10	0.004	F10101GL860	CCGT060201	097324						●	●	●	●										●
860	0.20	0.008	F10102GL860	CCGT060202	097241						●	●	●	●										●
860	0.40	0.016	F10104GL860	CCGT060204	097242						●	●	●	●										●
860	0.20	0.008	F10302GL860	CCGT09T302	097245						●	●	●	●										●
860	0.40	0.016	F10304GL860	CCGT09T304	097244						●	●	●	●										●
860	0.40	0.016	F10404GL860	CCGT120404	097738						●	●	●	●										●
860	0.80	0.031	F10408GL860	CCGT120408	097247						●	●	●	●										●
860	0.80	0.031	F10508ML860	CCMT160508	097249						●	●	●	●										●

Insert Form	Countersunk Screw		Torque Driver		Service Key		Technical Data	
	Part No.	Description	Part No.	Part No.	Torque	Key Size	Torque	Key Size
101	115676	M2.5 x 0.45 x 5	415514	115590	1.2 Nm	T8		
103	115672 ($\leq \phi 37 \text{ mm}$)	M3.5 x 0.6 x 7.5	415510	115664	3.0 Nm	T15		
103	115673 (>math>\phi 36 \text{ mm}</math>)	M3.5 x 0.6 x 9	415510	115664	3.0 Nm	T15		
104	215149	M4.5 x 0.75 x 11.5	415543	215150	5.0 Nm	T20		
105	215149	M4.5 x 0.75 x 11.5	415543	215150	5.0 Nm	T20		

Reference Key

Symbol	Machining Conditions
●	Good - Main Application
◐	Average - Main Application

Reference Key

Symbol	Insert Type
▼	Roughing - Main Application
▽	Roughing - Extended Application
▼▼▼	Finishing - Main Application
▽▽▽	Finishing - Extended Application

Insert Forms 101, 103, 104

Ceramic | CBN | PCD

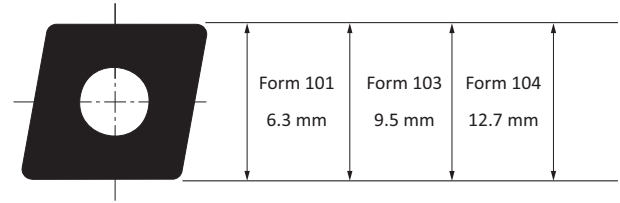
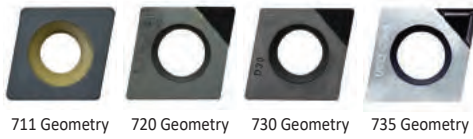

		Ceramic				CBN				PCD						
		Uncoated		Coated		Uncoated		Coated								
Steel	P															
Stainless Steel	M															
Cast Iron	K	▼					▼▼▼									
Non-Ferrous Materials	N									▼▼▼	▼▼▼					
Titanium	S															
Hard Materials	H															
Geometry	Radius		Description	ISO Code	Part No.	WCN06			WBN150	WBN200	WBN300	WBN450			PKDD30	PKDD50
	mm	in														
711	0.40	0.016	F10304GN711	CCGW09T304	297561	⚙️										
711	0.80	0.031	F10308GN711	CCGW09T308	297192	⚙️										
711	0.80	0.031	F10408GN711	CCGW120408	297249	⚙️										
711	1.20	0.047	F10412GN711	CCGW120412	297234	⚙️										
720	0.20	0.008	F10102GN720	CCGT060202	297501										●	
720	0.40	0.016	F10104GN720	CCGT060204	297502										●	
720	0.20	0.008	F10302GN720	CCGT09T302	297578										●	
720	0.40	0.016	F10304GN720	CCGT09T304	297483										●	
730	0.20	0.008	F10102GN730	CCGW060202	097462										●	●
730	0.40	0.016	F10104GN730	CCGW060204	297164										●	●
730	0.80	0.031	F10108GN730	CCGW060208	297165										●	●
730	0.20	0.008	F10302GN730	CCGW09T302	397251										●	●
730	0.40	0.016	F10304GN730	CCGW09T304	297533										●	●
730	0.40	0.016	F10404GN730	CCGW120404	397257										●	●
730	0.80	0.031	F10408GN730	CCGW120408	297871										●	●
735	0.20	0.008	F10102GN735	CCGT060202	297872										●	
735	0.40	0.016	F10104GN735	CCGT060204	397244										●	
735	0.20	0.008	F10302GN735	CCGT09T302	397252										●	
735	0.40	0.016	F10304GN735	CCGT09T304	297870										●	

Reference Key

Symbol	Machining Conditions
●	Good - Main Application
●	Average - Main Application
⚙️	Difficult - Main Application

Reference Key

Symbol	Insert Type
▼	Roughing - Main Application
▽	Roughing - Extended Application
▼▼▼	Finishing - Main Application
▽▽▽	Finishing - Extended Application

Insert Form	Countersunk Screw		Torque Driver		Service Key		Technical Data	
	Part No.	Dimensions	Part No.	Part No.	Torque	Key Size		
101	115676	M2.5 x 0.45 x 5	415514	115590	1.2 Nm	T8		
103	115672 ($\le \varnothing 37 \text{ mm}$)	M3.5 x 0.6 x 7.5	415510	115664	3.0 Nm	T15		
103	115673 (>math>\varnothing 36 \text{ mm}</math>)	M3.5 x 0.6 x 9	415510	115664	3.0 Nm	T15		
104	215149	M4.5 x 0.75 x 11.5	415543	215150	5.0 Nm	T20		

Insert Forms 101, 103, 104

CBN

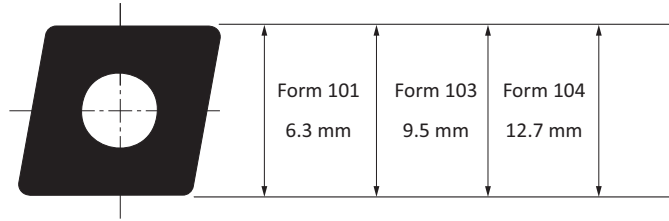
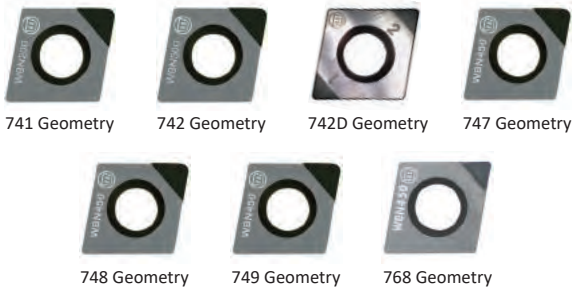

						CBN						
						Uncoated					Coated	
						WB	WB	WB	WB	WB	WB	WB
						150	200	300	450	448	300	
Geometry	Radius		Description	ISO Code	Part No.							
	mm	in										
Steel	P											
Stainless Steel	M											
Cast Iron	K					▽▽▽ ▽		▽▽▽ ▽	▽▽▽ ▽	▽▽▽ ▽		
Non-Ferrous Materials	N											
Titanium	S											
Hard Materials	H					▽▽▽ ▽	▽▽▽ ▽	▽▽▽ ▽			▽▽▽ ▽	
741	0.20	0.008	F10102GN741	CCGW060202	297290		●					
741	0.40	0.016	F10104GN741	CCGW060204	297291		●					
741	0.40	0.016	F10304GN741	CCGW09T304	297303		●					
742	0.20	0.008	F10102GN742	CCGW060202	297293			●				
742	0.40	0.016	F10104GN742	CCGW060204	297294			●				
742	0.40	0.016	F10304GN742	CCGW09T304	297306			●				
742D	0.20	0.008	F10102GN742D	CCGW060202	397949					●		●
742D	0.40	0.016	F10104GN742D	CCGW060204	397999					●		●
742D	0.40	0.016	F10304GN742D	CCGW090204	397931					●		●
742D	0.80	0.031	F10308GN742D	CCGW090208	397958					●		●
747	0.40	0.016	F10404GN747	CCGW120404	397260	●			●			
748	0.20	0.008	F10102GN748	CCGW060202	297787				●			
748	0.40	0.016	F10104GN748	CCGW060204	297788				●			
748	0.20	0.008	F10302GN748	CCGW09T302	297790				●			
748	0.40	0.016	F10304GN748	CCGW09T304	297419				●			
749	0.80	0.031	F10408GN749	CCGW120408	397261	●			●			
768	0.20	0.008	F10102GN768	CCGT060202	297486				●			
768	0.40	0.016	F10104GN768	CCGT060204	297659				●			
768	0.20	0.008	F10302GN768	CCGT09T302	397439				●			
768	0.40	0.016	F10304GN768	CCGT09T304	297660				●			

Reference Key

Symbol	Machining Conditions
●	Good - Main Application
●	Average - Main Application

Reference Key

Symbol	Insert Type
▽	Roughing - Main Application
▽	Roughing - Extended Application
▽▽▽	Finishing - Main Application
▽▽▽	Finishing - Extended Application

Insert Form	Countersunk Screw		Torque Driver		Service Key		Technical Data	
	Torque	Key Size	Torque	Key Size	Torque	Key Size	Torque	Key Size
101	115676	M2.5 x 0.4 x 5	415514	115590	1.2 Nm	T8		
103	115672 ($\phi 37\text{ mm}$)	M3.5 x 0.6 x 7.5	415510	115664	3.0 Nm	T15		
103	115673 (>math>\phi 36\text{ mm}</math>)	M3.5 x 0.6 x 9	415510	115664	3.0 Nm	T15		
104	215149	M4.5 x 0.75 x 11.5	415543	215150	5.0 Nm	T20		

Insert Form 39

Cermet | Carbide

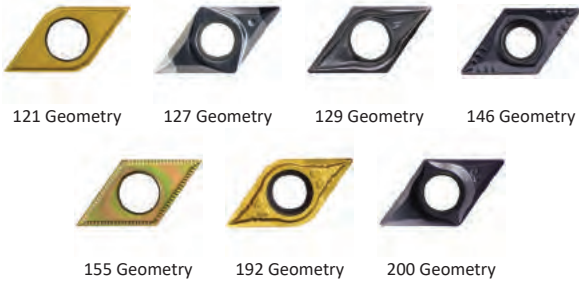

						Cermet						Carbide												
						Uncoated			Coated			Uncoated			Coated									
						WHT10	WHT12	WHT16	WHT32	WTC15	WTC121	WHW01	WHW16	WHC05	WHC81	WHC88	WHC98	WHC111	WHC114	WHC136	WHC164	WHC190		
Geometry	Radius		Description	ISO Code	Part No.																			
	mm	in																						
Steel	P																							
Stainless Steel	M																							
Cast Iron	K																							
Non-Ferrous Materials	N																							
Titanium	S																							
Hard Materials	H																							
121	0.20	0.008	F03902MN121	DCMT11T302	397787																			
121	0.40	0.016	F03904MN121	DCMT11T304	397788																			
127	0.20	0.008	F03702GN127	DCGT070202	397234																			
127	0.40	0.016	F03704GN127	DCGT070204	097787																			
127	0.20	0.008	F03902GN127	DCGT11T302	397235																			
127	0.40	0.016	F03904GN127	DCGT11T304	097559																			
129	0.20	0.008	F03702GN129	DCGT070202	397708																			
129	0.20	0.008	F03902GN129	DCGT11T302	397816																			
129	0.40	0.016	F03904GN129	DCGT11T304	397817																			
146	0.40	0.016	F03704MN146	DCMT070204	397968																			
146	0.80	0.031	F03708MN146	DCMT070208	397047																			
146	0.40	0.016	F03904MN146	DCMT11T304	397591																			
146	0.80	0.031	F03908MN146	DCMT11T308	397598																			
155	0.20	0.008	F03902MN155	DCMT11T302	397809																			
155	0.40	0.016	F03904MN155	DCMT11T304	397810																			
192	0.20	0.008	F03902MN192	DCMT11T302	397783																			
192	0.40	0.016	F03904MN192	DCMT11T304	297721																			
192	0.80	0.031	F03908MN192	DCMT11T308	397784																			
200	0.20	0.008	F03902GN200	DCGT11T302	397785																			
200	0.40	0.016	F03904GN200	DCGT11T304	397786																			

Reference Key

Symbol	Machining Conditions
●	Good - Main Application
◐	Average - Main Application
⚙	Difficult - Main Application

Reference Key

Symbol	Insert Type
▼	Roughing - Main Application
▽	Roughing - Extended Application
▼▼▼	Finishing - Main Application
▽▽▽	Finishing - Extended Application

				Technical Data	
Insert Form	Countersunk Screw	Torque Driver	Service Key	Torque	Key Size
39	115673 M3.5 x 0.6 x 9	414510	115664	3.0 Nm	T15

Insert Form 39

CBN | PCD

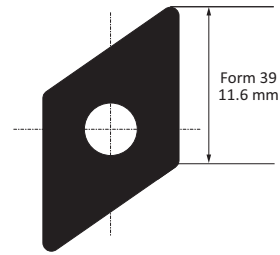





						CBN					PCD			
						Uncoated			Coated					
Steel						P								
Stainless Steel						M								
Cast Iron						K			K					
Non-Ferrous Materials						N					N			
Titanium						S								
Hard Materials						H								
Geometry	Radius		Description	ISO Code	Part No.	WBN150	WBN200	WBN300	WBN450	WBN200			PKDD30	PKDD50
	mm	in												
730	0.20	0.008	F03902GN730	DCGW11T302	397269								●	
730	0.40	0.016	F03904GN730	DCGW11T304	397270								●	
735	0.20	0.008	F03902GN735	DCGT11T302	397271								●	
735	0.40	0.016	F03904GN735	DCGT11T304	397272								●	
747	0.20	0.008	F03902GN747	DCGW11T302	397273	●			●					
747	0.40	0.016	F03904GN747	DCGW11T304	397274	●			●					

Reference Key

Symbol	Machining Conditions
●	Average - Main Application
⊕	Difficult - Main Application

Reference Key

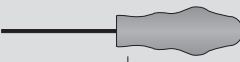
Symbol	Insert Type
▼	Roughing - Main Application
▽	Roughing - Extended Application
▼▼	Finishing - Main Application
▽▽	Finishing - Extended Application

				Technical Data		
Insert Form	Countersunk Screw		Torque Driver	Service Key	Torque	Key Size
39	115673	M3.5 x 0.6 x 9	414510	115664	3.0 Nm	T15

Insert Forms 112, 113, 114

Carbide

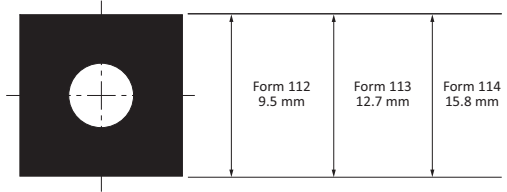

						Carbide																	
						Uncoated		Coated															
Steel P									▽▽	▽▽	▽▽	▽▽	▽▽	▽▽	▽▽	▽▽	▽▽	▽▽	▽▽	▽▽	▽▽	▽▽	
Stainless Steel M									▽		▽▽	▽	▽	▽	▽	▽	▽	▽	▽	▽	▽	▽	
Cast Iron K							▽▽		▽▽	▽▽	▽▽	▽▽		▽▽	▽▽	▽▽	▽▽		▽▽	▽▽		▽▽	
Non-Ferrous Materials N							▽▽																
Titanium S							▽▽		▽▽					▽▽		▽▽	▽▽					▽▽	
Hard Materials H										▽▽		▽▽					▽▽			▽▽			
Geometry	Radius		Description	ISO Code	Part No.	WHW01	WHW16	WHC05	WHC30	WHC77	WHC79	WHC81	WHC88	WHC98	WHC111	WHC114	WHC136	WHC164	WHC190				
108	0.40	0.016	F11204MN108	SCMT09T304	297535									●									
108	0.80	0.031	F11308MN108	SCMT120408	397110									●									
127	0.40	0.016	F11204GN127	SCGT09T304	097539		●																
127	0.40	0.016	F11304GN127	SCGT120404	397590		●																
127	0.80	0.031	F11308GN127	SCGT120408	097566		●																
145	0.80	0.031	F11208GN145	SCGT09T308	297996										●								
145	0.80	0.031	F11308GN145	SCGT120408	297997										●								
146	0.40	0.016	F11204MN146	SCMT09T304	397940							●	⚙										
146	0.80	0.031	F11208MN146	SCMT09T308	397992							●	⚙										
146	0.40	0.016	F11304MN146	SCMT12T304	397049							●	⚙										
146	0.80	0.031	F11308MN146	SCMT12T308	397969							●	⚙										
158	0.80	0.031	F11308MN158	SCMT120408	297497						●												
158	1.20	0.047	F11412MN158	SCMT150512	097252				⚙														
192	0.40	0.016	F11204MN192	SCMT09T304	397741														●	⚙			
192	0.80	0.031	F11208MN192	SCMT09T308	397640														●	⚙			
192	0.80	0.031	F11308MN192	SCMT120408	397709														●	⚙			
192	1.20	0.047	F11312MN192	SCMT120412	397710															⚙			
199	0.40	0.016	F11204MN199	SCMT09T304	397703														●				
199	0.80	0.031	F11208MN199	SCMT09T308	397704														●				
199	0.80	0.031	F11308MN199	SCMT120408	397705														●				
711	0.80	0.031	F11308MN711	SCMT120408	297212					●													

Reference Key

Symbol	Machining Conditions
●	Good - Main Application
◐	Average - Main Application
⚙	Difficult - Main Application

Reference Key

Symbol	Insert Type
▽	Roughing - Main Application
▽	Roughing - Extended Application
▽▽	Finishing - Extended Application

Insert Form	Countersunk Screw		Torque Driver		Service Key		Technical Data	
	Part No.	Dimensions	Part No.	Part No.	Torque	Key Size		
112	115672 ($\phi 37\text{ mm}$)	M3.5 x 0.6 x 7.5	415510	115664	3.0 Nm	T15		
112	115673 (>math>\phi 36\text{ mm}</math>)	M3.5 x 0.6 x 9	415510	115664	3.0 Nm	T15		
113	215149	M4.5 x 0.75 x 11.5	415543	215150	5.0 Nm	T20		
114	215149	M4.5 x 0.75 x 11.5	415543	215150	5.0 Nm	T20		

Insert Forms 04, 05

Carbide



880 Geometry



811 Geometry

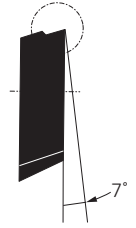
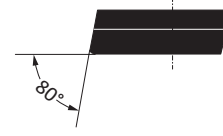
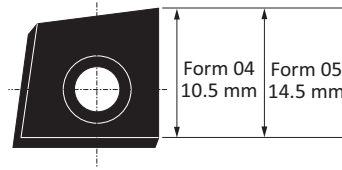

						Carbide										
						Uncoated			Coated							
Material	ISO Code															
Steel	P											▼	▼	▼		
Stainless Steel	M											▽	▽	▽		
Cast Iron	K											▼	▼	▼		
Non-Ferrous Materials	N													▽		
Titanium	S													▽		
Hard Materials	H															
Geometry	Radius		Description	ISO Code	Part No.	WHW16	WHC05	WHC18	WHC19	WHC79	WHC98	WHC111	WHC114	WHC170	WHC168	WHC198
	mm	in														
880	0.40	0.016	F00404ML880	-	397595											●
880	0.40	0.016	F00504ML880	-	397593										●	●
880	0.80	0.031	F00508ML880	-	397594									●	●	●
811	0.80	0.031	F00508ML811	-	397844									●	●	●

Reference Key

Symbol	Machining Conditions
●	Average - Main Application
●	Difficult - Main Application

Reference Key

Symbol	Insert Type
▼	Roughing - Main Application
▽	Roughing - Extended Application

Insert Form	Countersunk Screw		Torque Driver	Service Key	Technical Data	
					Torque	Key Size
04	415977	M4 x 0.7 x 7.9	415510	115664	3.0 Nm	T15
05	415949	M4 x 0.7 x 11	415543	215150	5.0 Nm	T20

Radial Grooving Insert Forms 89, 90, 91

Carbide

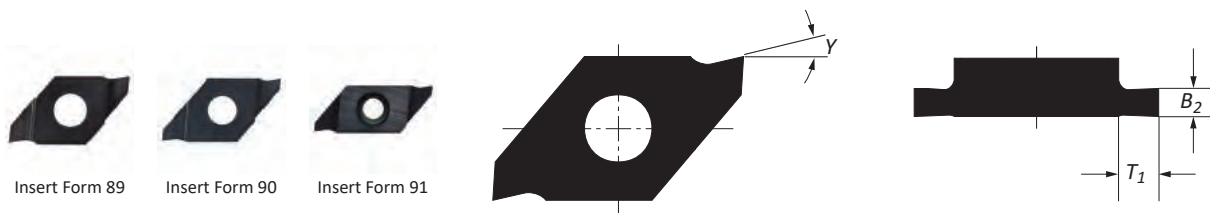

						Carbide													
						Uncoated			Coated										
Steel						P													
Stainless Steel						M													
Cast Iron						K			▽▽									▽▽	
Non-Ferrous Materials						N			▽▽										
Titanium						S			▽▽									▽▽	
Hard Materials						H													
Insert Form	B ₂	Y	T ₁	Ring Width	Part No.	WHW01	WHW16	WHW20	WHC05	WHC18	WHC19	WHC79	WHC98	WHC111	WHC114	WHC136	WHC164		
89	1.24	13°	1.30	1.00	097257			●									●		
89	1.44	13°	1.30	1.20	097258			●									●		
89	1.74	13°	1.50	1.50	097259			●									●		
90	1.99	9°	2.40	1.75	097256			●									●		
90	2.29	9°	2.40	2.00	097253			●									●		
90	2.79	9°	2.40	2.50	097254			●									●		
90	3.29	9°	2.40	3.00	097255			●									●		
91	2.79	9°	2.40	2.50	097260			●									●		
91	3.29	9°	2.40	3.00	097261			●									●		
91	4.29	9°	3.30	4.00	097262			●									●		
91	5.29	9°	4.50	5.00	097294			●									●		

Reference Key

Symbol	Machining Conditions
●	Average - Main Application

Reference Key

Symbol	Insert Type
▽▽	Universal - Main Application
▽	Universal - Extended Application

Insert Form	Countersunk Screw		Torque Driver	Service Key	Technical Data	
					Torque	Key Size
89	115676	M2.5 x 0.45 x 5	415514	115590	1.2 Nm	T8
90	115531	M3 x 0.5 x 7.5	415514	115590	1.2 Nm	T8
91	115802	M3 x 0.5 x 12	415514	115590	1.2 Nm	T8

Radial Grooving Insert Forms 89, 90, 91

Carbide

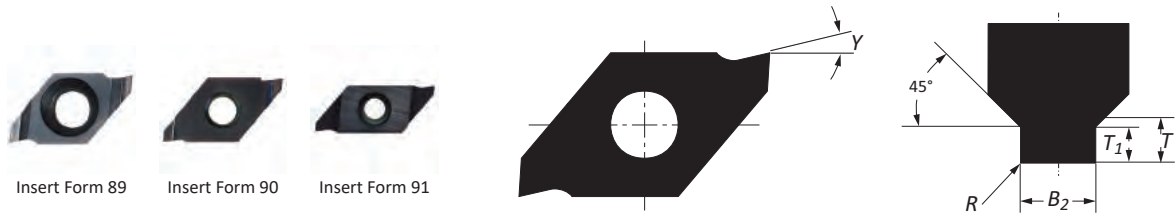

									Carbide															
									Uncoated			Coated												
Steel									P														▼▼	
Stainless Steel									M													▼▼		
Cast Iron									K													▼▼		
Non-Ferrous Materials									N															
Titanium									S													▼▼		
Hard Materials									H															
Insert Form	Boring Ø	B ₂	Y	R	T ₁	T	Ring Width	Part No.	WHW01	WHW16	WHW20	WHC05	WHC18	WHC19	WHC79	WHC98	WHC111	WHC114	WHC136	WHC164				
89	24.00 - 26.00	1.44	13°	0.10	0.54	0.65	1.20	297937																
89	28.00 - 30.00	1.44	13°	0.10	0.64	0.75	1.20	297938																
89	31.00 - 32.00	1.44	13°	0.10	0.78	0.91	1.20	297939																
89	34.00	1.74	13°	0.10	0.78	0.91	1.50	297940																
89	35.00 - 38.00	1.74	13°	0.10	0.93	1.06	1.50	297941																
90	40.00 - 48.00	1.99	9°	0.15	1.18	1.31	1.75	297942																
90	50.00 - 63.00	2.29	9°	0.15	1.43	1.58	2.00	297943																
91	65.00 - 78.00	2.79	9°	0.20	1.43	1.58	2.50	297944																
91	80.00 - 82.00	2.79	9°	0.20	1.68	1.84	2.50	297945																
91	85.00 - 100.00	3.29	9°	0.20	1.68	1.84	3.00	297946																
91	102.00 - 145.00	4.29	9°	0.20	1.94	2.14	4.00	297947																

III

Reference Key

Symbol	Machining Conditions
●	Average - Main Application

Reference Key

Symbol	Insert Type
▼▼	Universal - Main Application
▼▼	Universal - Extended Application

Insert Form	Countersunk Screw		Torque Driver		Service Key		Technical Data	
	Part No.	Size	Part No.	Part No.	Torque	Key Size	Torque	Key Size
89	115676	M2.5 x 0.45 x 5	415514	115590	1.2 Nm	T8	1.2 Nm	T8
90	115531	M3 x 0.5 x 7.5	415514	115590	1.2 Nm	T8	1.2 Nm	T8
91	115802	M3 x 0.5 x 12	415514	115590	1.2 Nm	T8	1.2 Nm	T8

Axial Grooving Insert Blanks Form 304

Carbide



			Carbide											
			Uncoated			Coated								
Material	Grade		WHW01	WHW16	WHW20	WHC05	WHC18	WHC19	WHC79	WHC98	WHC111	WHC114	WHC136	WHC164
Steel	P													
Stainless Steel	M													
Cast Iron Non-Ferrous Materials	K				▽▽									
Non-Ferrous Materials	N				▽▽									
Titanium	S				▽▽									
Hard Materials	H													
Geometry	S ₁	Part No.	WHW01	WHW16	WHW20	WHC05	WHC18	WHC19	WHC79	WHC98	WHC111	WHC114	WHC136	WHC164
	3.50	297150			●									
	4.30	297151			●									
	5.30	297152			●									
	6.50	297154			●									
	7.50	297493			●									
	3.50	397850			●									
	4.30	397851			●									
	5.30	397852			●									
	6.50	397853			●									
	7.50	397854			●									

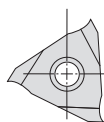

Other insert types available upon request.



Two-Sided Cutting Form

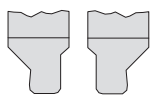

Single-Sided Cutting Form (Right / Left)



Two-Sided Angle Cutting



With Corner Radius



Full Radius

Reference Key

Symbol	Machining Conditions
●	Average - Main Application

Reference Key

Symbol	Insert Type
▽▽	Universal - Main Application
▽	Universal - Extended Application

				Technical Data	
Insert Form	Countersunk Screw	Torque Driver	Service Key	Torque	Key Size
304	215392 M5 x 0.8 x 12.9	415543	215150	5.0 Nm	T20

Axial Grooving O-Rings for Single Cutter Tools Insert Form 304

Carbide

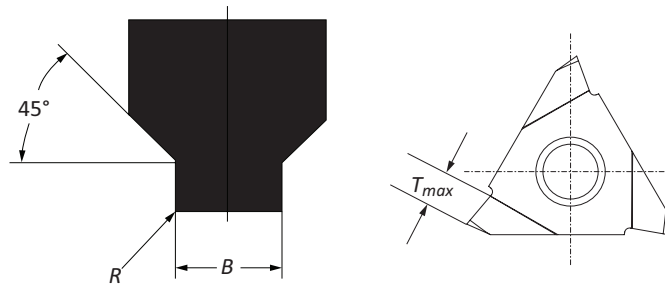

								Carbide															
								Uncoated				Coated											
Steel								P															▼▼
Stainless Steel								M															▽▽
Cast Iron Non-Ferrous Materials								K															▼▼
Non-Ferrous Materials								N															
Titanium								S															▼▼
Hard Materials								H															
Geometry	Boring Range	O-Ring Cross Section	B + 0.05	B_max	T_max	R ± 0.05	Part No.	WHW01	WHW16	WHW20	WHC05	WHC18	WHC19	WHC79	WHC98	WHC111	WHC114	WHC136	WHC164				
	20 - 54	1.00	1.50	1.50	1.65	0.20	297969													●			
	20 - 54	1.50	2.20	2.20	2.35	0.30	297970														●		
	20 - 54	2.00	2.90	2.90	3.15	0.40	297971														●		
	20 - 54	2.50	3.50	3.50	3.85	0.50	297972														●		
	20 - 54	3.00	4.10	4.10	4.45	0.60	297973														●		
	20 - 54	4.00	5.40	5.40	4.95	0.80	297974															●	
	20 - 54	5.00	6.80	6.80	4.95	0.80	297975															●	

Reference Key

Symbol	Machining Conditions
●	Average - Main Application

Reference Key

Symbol	Insert Type
▼▼	Universal - Main Application
▽▽	Universal - Extended Application

Insert Form	Countersunk Screw		Torque Driver	Service Key	Technical Data	
304	215392	M5 x 0.8 x 12.9	415543	215150	Torque	Key Size
					5.0 Nm	T20

Axial Grooving O-Rings for Twin Cutter Tools Insert Form 304

Carbide

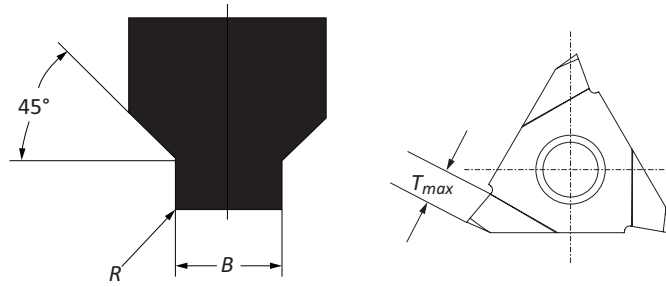

		Carbide																	
		Uncoated							Coated										
Material	Grade	WHW01	WHW16	WHW20	WHC05	WHC18	WHC19	WHC79	WHC98	WHC111	WHC114	WHC136	WHC164						
Steel	P													▼▼					
Stainless Steel	M													▽▽					
Cast Iron Non-Ferrous Materials	K													▼▼					
Non-Ferrous Materials	N																		
Titanium	S													▼▼					
Hard Materials	H																		
Geometry	Boring Range	O-Ring Cross Section	B + 0.05	B _{max}	T _{max}	R ± 0.05	Part No.	WHW01	WHW16	WHW20	WHC05	WHC18	WHC19	WHC79	WHC98	WHC111	WHC114	WHC136	WHC164
	53.00 - 1000.00	1.00 - 1.50	1.50	2.50	1.65	0.20	297976												
	53.00 - 1000.00	1.50 - 2.40	2.20	3.70	2.35	0.30	297977												●
	53.00 - 1000.00	2.40 - 4.00	3.40	5.70	3.65	0.50	297978												●
	53.00 - 1000.00	4.00 - 5.50	5.40	9.10	4.95	0.80	297979												●

Reference Key

Symbol	Machining Conditions
●	Average - Main Application

Reference Key

Symbol	Insert Type
▼▼	Universal - Main Application
▽▽	Universal - Extended Application

Insert Form	Countersunk Screw		Torque Driver	Service Key	Technical Data	
304	215392	M5 x 0.8 x 12.9	415543	215150	Torque	Key Size
					5.0 Nm	T20

Insert Form 325

Carbide

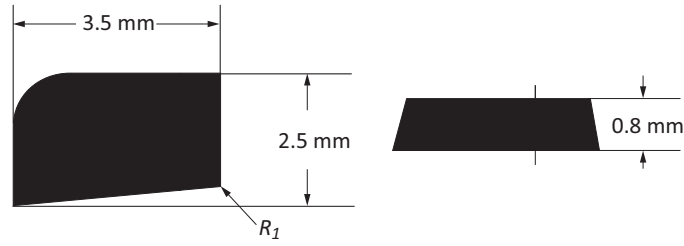

				Carbide											
				Uncoated			Coated								
Material	Grade	Radius R_1	Part No.	WHW01	WHW16	WHW20	WHC05	WHC18	WHC19	WHC79	WHC98	WHC111	WHC114	WHC136	WHC164
Steel	P													▼▼▼	
Stainless Steel	M													▼▼▼	
Cast Iron Non-Ferrous Materials	K					▼▼▼								▼▼▼	
Non-Ferrous Materials	N					▼▼▼									
Titanium	S													▼▼▼	
Hard Materials	H														
Geometry	Radius R_1	Description	Part No.												
	860	0.10	F32501CN860			●								●	

Reference Key

Symbol	Machining Conditions
●	Average - Main Application

Reference Key

Symbol	Insert Type
▼▼▼	Finishing - Main Application
▽▽▽	Finishing - Extended Application

Insert Form	Countersunk Screw	Clamping Jaw	Torque Driver	Service Key	Technical Data	
					Torque	Key Size
325	315321 M1.6 x 0.35 x 3	315320	-	315322	0.3 Nm	0.5x3

Insert Accessories

Countersunk Screws | Torque Drivers

Insert Form	Countersunk Screw		Clamping Jaw	Torque Driver		Technical Data	
				Torque Driver	Service Key	Torque	Key Size
04	415977	M4 x 0.7 x 7.9	–	415510	115664	3.0 Nm	T15
05	415949	M4 x 0.7 x 11	–	415543	215150	5.0 Nm	T20
20	115535	M2 x 0.4 x 5	–	415508	115591	0.9 Nm	T7
39	115673	M3.5 x 0.6 x 9	–	414510	115664	3.0 Nm	T15
47	315324	M1.8 x 0.35 x 4	315323	–	115537	0.5 Nm	T6
89	115676	M2.5 x 0.45 x 5	–	415514	115590	1.2 Nm	T8
90	115531	M3 x 0.5 x 7.5	–	415514	115590	1.2 Nm	T8
91	115802	M3 x 0.5 x 12	–	415514	115590	1.2 Nm	T8
101	115676	M2.5 x 0.45 x 5	–	415514	115590	1.2 Nm	T8
103	115672 (<math>\lt; \phi 37 \text{ mm}</math>)	M3.5 x 0.6 x 7.5	–	415510	115664	3.0 Nm	T15
103	115673 (>math>\gt; \phi 36 \text{ mm}</math>)	M3.5 x 0.6 x 9	–	415510	115664	3.0 Nm	T15
104	215149	M4.5 x 0.75 x 11.5	–	415543	215150	5.0 Nm	T20
105	215149	M4.5 x 0.75 x 11.5	–	415543	215150	5.0 Nm	T20
111	115531	M3 x 0.5 x 7.5	–	415514	115590	1.2 Nm	T8
112	115672 (<math>\lt; \phi 37 \text{ mm}</math>)	M3.5 x 0.6 x 7.5	–	415510	115664	3.0 Nm	T15
112	115673 (>math>\gt; \phi 36 \text{ mm}</math>)	M3.5 x 0.6 x 9	–	415510	115664	3.0 Nm	T15
113	215149	M4.5 x 0.75 x 11.5	–	415543	215150	5.0 Nm	T20
114	215149	M4.5 x 0.75 x 11.5	–	415543	215150	5.0 Nm	T20
161	115676	M2.5 x 0.45 x 5	–	415514	115590	1.2 Nm	T8
163	115673	M3.5 x 0.6 x 9	–	415510	115664	3.0 Nm	T15
211	215377	M2 x 0.4 x 4	–	415507	115537	0.6 Nm	T6
262	215987	M2.5 x 0.45 x 6	–	415514	115590	1.2 Nm	T8
264	115673	M3.5 x 0.6 x 9	–	415510	115664	3.0 Nm	T15
304	215392	M5 x 0.8 x 12.9	–	415543	215150	5.0 Nm	T20
325	315321	M1.6 x 0.35 x 3	315320	–	315322	0.3 Nm	0.5x3
394	215915	M2.5 x 0.45 x 7	–	415514	115590	1.1 Nm	T8
395	215985	M3 x 0.5 x 7.5	–	415514	115590	1.2 Nm	T8
396	415320	M3.5 x 0.6 x 11	–	415510	115664	3.0 Nm	T15
397	215149	M4.5 x 0.75 x 11.5	–	415543	215150	5.0 Nm	T20

Insert Accessories

Countersunk Screws | Torque Drivers

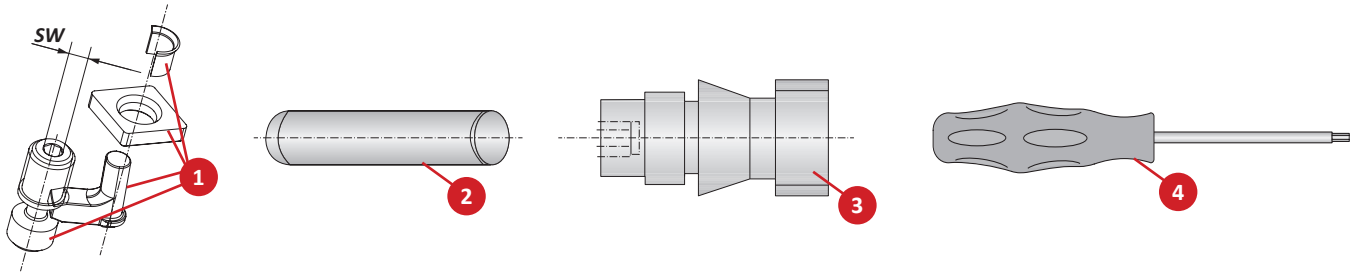

Insert Form	1. Clamping Set		2. Mounting Arbor for Sleeve	3. Clamping Bolt		4. Service Key	
	Part No.	Key Size	Part No.	Part No.	Key Size	Part No.	Key Size
75	315004	s3	415642	-	-	415578	s3
123	315003	s3	415642	115775	s2.5	415578 115575	s3 s2.5
124	315054	s3	415644	115776	s3	415578 115630	s3 s3

Technical Information

Surface Finish | General Formulas

The corner radius of replaceable inserts is very important in finish machining. Large corner radii 0.8 mm (0.031") or higher allow for high feed rates with good surface quality.

The expected surface quality can be estimated by using the function of corner radius and feed rate formula.

	<ol style="list-style-type: none"> 1. The larger the corner radius and the lighter the feed rate is, the better the surface quality.
	<ol style="list-style-type: none"> 2. If the feed is approximately 1/3 of the corner radius, the better the machining time and surface finish will be in finish machining applications.
	<ol style="list-style-type: none"> 3. A larger corner radius increases radial forces, which can negatively affect dimensional accuracy. Large corner radii also require increased depth of cut.



Minimum depth of cut (a_p) should at least match the corner radius. This minimizes the radial forces.

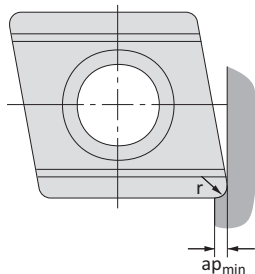

General Formulas		
Cutting Speed	$\frac{V_c = D \times \pi \times n}{1000}$	(M/min)
RPM	$\frac{n = V_c \times 1000}{D \times \pi}$	(min ⁻¹)
Feed Speed	$V_f = f \times n$	(mm/min)
	$D = \text{Machining } \varnothing$	(mm)
	$f = \text{Feed}$	(mm/u)
	$V_c = \text{Cutting Speed}$	(M/min)
	$n = \text{RPM}$	(min ⁻¹)

Technical Information

Wiper Geometries

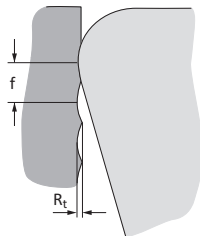
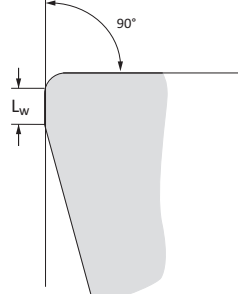
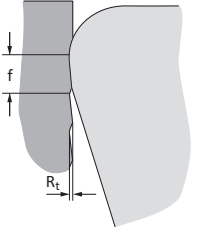
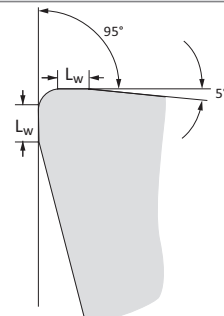
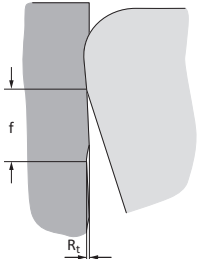
Replaceable Inserts with Wiper Geometry		Wiper Geometry for 90° Approach Angle	
<p>Insert with conventional corner radius with feed (f)</p> 		<p>Replaceable inserts produce a right-angled step at the bottom of the hole. When used in a Wohlhaupter standard insert holder that has a 90° approach angle, the secondary wiper cutting edge is nearly parallel with the wall of the hole.</p> <p>Wiper geometry for 90° approach angle L_w = length of the wiper secondary cutting edge</p> 	
<p>Insert with wiper geometry radius with same feed (f)</p> 		<p style="text-align: center;">Wiper Geometry for 95° Approach Angle</p> <p>Wiper inserts can also be used with 95° insert holders, which are included in the Wohlhaupter standard insert range.</p> <p>Wiper geometry for 95° approach angle (left and right cutting) L_w = length of the secondary wiper cutting edge</p> 	
<p>Insert with wiper geometry with increased feed (f)</p> 			

Recommended Cutting Data | Metric (mm)

ISO	Material	(BHN) Hardness	Grade	*Speed M / Min	Recommended Feed (mm / tooth) Nose Radii			
					0.1 mm	0.2 mm	0.4 mm	0.8 mm
P	Free-Machining Steel 1118, 1215, 12L14, etc.	100 - 250	Carbide	150 - 300	0.02 - 0.08	0.05 - 0.13	0.10 - 0.15	0.15 - 0.23
	Low-Carbon Steel 1010, 1020, 1025, 1522, 1144, etc.	85 - 275	Carbide	145 - 280	0.02 - 0.05	0.05 - 0.10	0.08 - 0.13	0.13 - 0.20
	Medium-Carbon Steel 1030, 1040, 1050, 1527, 1140, 1151, etc.	125 - 325	Carbide	145 - 280	0.02 - 0.05	0.05 - 0.10	0.08 - 0.13	0.13 - 0.20
	Alloy Steel 4140, 5140, 8640, etc.	125 - 375	Carbide	120 - 215	0.02 - 0.05	0.05 - 0.10	0.08 - 0.13	0.13 - 0.20
	High-Strength Alloy 4340, 4330V, 300M, etc.	225 - 400	Carbide	100 - 180	0.02 - 0.05	0.05 - 0.10	0.08 - 0.13	0.13 - 0.20
	Structural Steel A36, A285, A516, etc.	100 - 350	Carbide	145 - 280	0.02 - 0.05	0.05 - 0.10	0.08 - 0.13	0.13 - 0.20
	Tool Steel H-13, H-21, A-4, O-2, S-3, etc.	150 - 250	Carbide	100 - 180	0.02 - 0.05	0.05 - 0.08	0.08 - 0.10	0.10 - 0.15
	High-Temp Alloy Hastelloy B, Inconel 600, etc.	140 - 310	Carbide	30 - 70	0.02 - 0.05	0.05 - 0.08	0.08 - 0.13	0.10 - 0.15
S	Titanium Alloy	140 - 310	Carbide	40 - 90	0.02 - 0.05	0.05 - 0.08	0.08 - 0.13	0.10 - 0.15
	Aerospace Alloy S82	185 - 350	Carbide	40 - 90	0.02 - 0.05	0.05 - 0.08	0.08 - 0.13	0.10 - 0.15
	Stainless Steel 400 Series 416, 420, etc.	185 - 350	Carbide	90 - 160	0.02 - 0.05	0.05 - 0.10	0.08 - 0.10	0.10 - 0.15
M	Stainless Steel 300 Series 304, 316, 17-4PH, etc.	135 - 275	Carbide	90 - 160	0.02 - 0.05	0.05 - 0.10	0.08 - 0.10	0.10 - 0.15
	Super Duplex Stainless Steel	135 - 275	Carbide	90 - 160	0.02 - 0.05	0.05 - 0.10	0.08 - 0.10	0.10 - 0.15

*Not to exceed max recommended RPM for boring head found in corresponding Wohlhaupter Operation Manual

Deep Hole Boring Speed Adjustment

⚠ For Dynamic Boring Tool Length

Boring Type	7xD	8xD	9xD	10xD
Roughing	❖	❖	❖	❖
Finishing	0.70	0.50	0.30	❖

❖ Contact our Application Engineering department for assistance when boring these depths without NOVI^{TECH}.

Deep Hole Boring Speed Adjustment

⚠ For Dynamic Boring Tool NOVI^{TECH} Length

Boring Type	8xD	9xD	10xD
Roughing	0.80	0.60	0.40
Finishing	0.90	0.70	0.50

*Not to exceed recommended RPM printed on NOVI^{TECH} module

Recommended Speed Example

If the recommended speed for a finish boring assembly under 5xD is 120 M/Min, then the speed for a 10xD finish boring assembly in the same application would be 60 M/Min (120 M/Min x 0.50 = 60 M/Min)

5xD = 120 M/Min

10xD = 60 M/Min

IMPORTANT: Max spindle speed refers to maximum possible speed for individual boring head and is not a recommended parameter. Factory technical assistance is available for your specific applications through our Application Engineering department. *email: engineering.eu@alliedmachine.com*

⚠ WARNING Tool failure can cause serious injury. To prevent:

- Do not exceed recommended 10xD length-to-diameter ratio or exceed 4 total components (including shank)
- When using Alu-Line components, do not exceed recommended 5xD length-to-diameter ratio
- When using tool steel components, do not exceed recommended 6xD length-to-diameter ratio
- When using heavy metal components, do not exceed recommended 8xD length-to-diameter ratio
- When using a carbide shank, do not exceed recommended 9xD length-to-diameter ratio
- When using a NOVI^{TECH} module, do not exceed recommended 10xD length-to-diameter ratio

Factory technical assistance is available for your specific applications through our Application Engineering department. *email: engineering.eu@alliedmachine.com*

Recommended Cutting Data | Metric (mm)

ISO	Material	(BHN) Hardness	Grade	*Speed M / Min	Recommended Feed (mm / tooth) Nose Radii			
					0.1 mm	0.2 mm	0.4 mm	0.8 mm
H	Wear Plate Hardox®, AR400, T-1, etc.	400 - 600	Carbide	30 - 60	0.02 - 0.05	0.05 - 0.08	0.08 - 0.10	0.10 - 0.15
			CBN	70 - 180	0.02 - 0.05	0.05 - 0.08	0.08 - 0.10	0.10 - 0.15
	Hardened Steel	300 - 500	Carbide	40 - 80	0.02 - 0.05	0.05 - 0.08	0.08 - 0.10	0.10 - 0.15
			CBN	70 - 180	0.02 - 0.05	0.05 - 0.08	0.08 - 0.10	0.10 - 0.15
K	SG / Nodular Cast Iron	120 - 320	Carbide	145 - 260	0.02 - 0.05	0.05 - 0.10	0.08 - 0.13	0.13 - 0.20
	Grey / White Iron	180 - 320	Carbide	180 - 320	0.02 - 0.05	0.05 - 0.10	0.08 - 0.13	0.13 - 0.20
			CBN	400 - 1000	0.02 - 0.05	0.05 - 0.10	0.08 - 0.13	0.13 - 0.20
N	Cast Aluminium	30 - 180	Carbide	260 - 850	0.02 - 0.05	0.05 - 0.10	0.08 - 0.13	0.13 - 0.20
			PCD	495 - 1995	0.02 - 0.05	0.05 - 0.10	0.08 - 0.13	0.13 - 0.20
	Wrought Aluminium	30 - 180	Carbide	205 - 600	0.02 - 0.05	0.05 - 0.13	0.10 - 0.15	0.15 - 0.23
	Aluminium Bronze	100 - 250	Carbide	145 - 280	0.02 - 0.05	0.05 - 0.10	0.10 - 0.13	0.13 - 0.20
Copper	60	Carbide	100 - 180	0.02 - 0.05	0.05 - 0.08	0.08 - 0.10	0.10 - 0.13	

*Not to exceed max recommended RPM for boring head found in corresponding Wohlhaupter Operation Manual

Deep Hole Boring Speed Adjustment

⚠ For Dynamic Boring Tool Length

Boring Type	7xD	8xD	9xD	10xD
Roughing	❖	❖	❖	❖
Finishing	0.70	0.50	0.30	❖

❖ Contact our Application Engineering department for assistance when boring the depths without NOVI^{TECH}.

Deep Hole Boring Speed Adjustment

⚠ For Dynamic Boring Tool NOVI^{TECH} Length

Boring Type	8xD	9xD	10xD
Roughing	0.80	0.60	0.40
Finishing	0.90	0.70	0.50

*Not to exceed recommended RPM printed on NOVI^{TECH} module

Recommended Speed Example

If the recommended speed for a finish boring assembly under 5xD is 120 M/Min, then the speed for a 10xD finish boring assembly in the same application would be 60 M/Min (120 M/Min x 0.50 = 60 M/Min)

5xD = 120 M/Min

10xD = 60 M/Min

IMPORTANT: Max spindle speed refers to maximum possible speed for individual boring head and is not a recommended parameter. Factory technical assistance is available for your specific applications through our Application Engineering department. *email: engineering.eu@alliedmachine.com*

⚠ WARNING Tool failure can cause serious injury. To prevent:

- Do not exceed recommended 10xD length-to-diameter ratio or exceed 4 total components (including shank)
- When using Alu-Line components, do not exceed recommended 5xD length-to-diameter ratio
- When using tool steel components, do not exceed recommended 6xD length-to-diameter ratio
- When using heavy metal components, do not exceed recommended 8xD length-to-diameter ratio
- When using a carbide shank, do not exceed recommended 9xD length-to-diameter ratio
- When using a NOVI^{TECH} module, do not exceed recommended 10xD length-to-diameter ratio

Factory technical assistance is available for your specific applications through our Application Engineering department. *email: engineering.eu@alliedmachine.com*

Boring Insert Wear Patterns

Built-up Edge

Potential Problem

- Machined material adheres to the cutting edge of insert
- When it breaks, the edge becomes brittle and cracks
- This can negatively affect machined surface

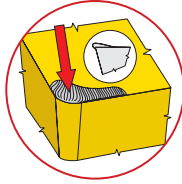

Possible Solution

- Increase temperature by increasing speed or feed
- Use an insert with higher lubricity coating
- Choose a freer cutting insert geometry

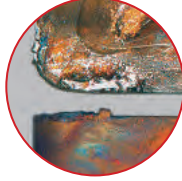

Comb Cracks

Potential Problem

- Caused by high stress on the cutting edge during interrupted cuts

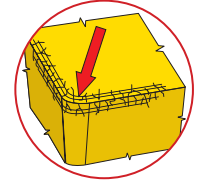

Possible Solution

- Switch off coolant or increase coolant flow to obtain an even temperature level
- Reduce cutting speed
- Use tougher insert grade

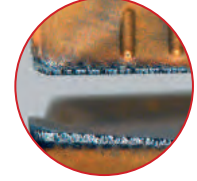

Flank Wear

Potential Problem

- Caused by friction between the insert and machined material
- It cannot be fully eliminated, but it can be reduced

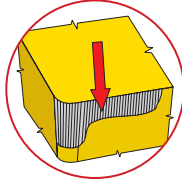

Possible Solution

- Use a more wear-resistant grade
- Reduce cutting speed
- Use coolant or increase coolant flow to the cutting edge

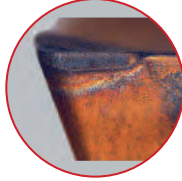

Plastic Deformation

Potential Problem

- Caused by high thermal stress on the cutting edge from excessive feed rate and cutting speed

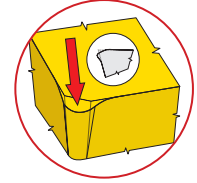

Possible Solution

- Use a more wear-resistant grade
- Reduce cutting speed
- Reduce feed rate
- Use coolant or increase coolant flow to the cutting edge

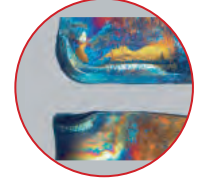

Cratering

Potential Problem

- Appears when the geometry is too neutral or material is too hard for the substrate

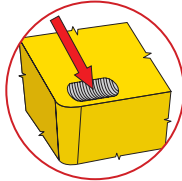

Possible Solution

- Use a more wear-resistant grade
- Reduce cutting speed or feed
- Use coolant or increase coolant flow to the cutting edge

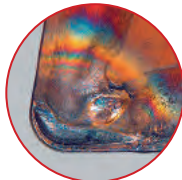

Chipping of Cutting Edge (Out of Cut)

Potential Problem

- Caused by poor chip control
- Can damage the portion of the cutting edge that might not be engaged in the cut

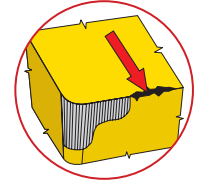

Possible Solution

- Change feed rate to gain chip control
- Select a tool with a different approach angle
- Use an insert with a different geometry
- Use a tougher grade of carbide

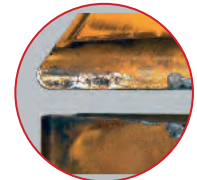

Notch Wear

Potential Problem

- Occurs when cutting edge of insert comes in contact with surface of machined material
- Caused by hardening of surface layer of material and burrs
- Often appears on stainless austenitic steels and other high-temperature alloy steels

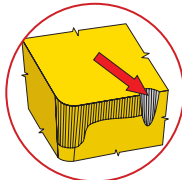

Possible Solution

- Use a more wear-resistant grade (Al_2O_3)
- Select a tool with a smaller approach angle
- Vary the radial depth of cut
- Use coolant or increase coolant flow to the cutting edge

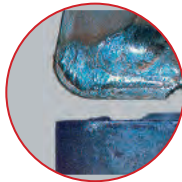

Insert Fracture

Potential Problem

- Caused by workpiece material, grade, condition, the rigidity of the machine-tool workpiece, extent of wear, and cutting conditions

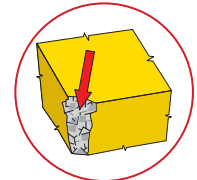

Possible Solution

- Use a tougher grade of carbide
- Reduce the feed and depth of cut
- Use an insert with a stronger chip breaker
- Use an insert with a bigger corner radius

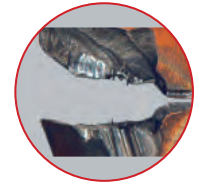

SECTION

B10-I

Modular Tool Holders

Wohlhaupter® Modular Tool Holders

Adapter Sleeves | Drill Chucks | Collet Chucks | Milling Arbors | Holding Arbors | Hydraulic Clamping Chucks
Tapping Chucks | Boring Bar Blanks



Clamping Tools with MVS Connection

Wohlhaupter offers a complete range of tool holders that incorporates the MVS connection. Our clamping tools allow for smaller MVS tools to connect and provide a quick and inexpensive alternative to special tooling. Many of the clamping tools also feature coolant-through capabilities.

Your safety and the safety of others is very important. This catalogue contains important safety messages. Always read and follow all safety precautions.



This triangle is a safety hazard symbol. It alerts you to potential safety hazards that can cause tool failure and serious injury.

When you see this symbol in the catalogue, look for a related safety message that may be near this triangle or referred to in the nearby text.

There are safety signal words also used in the catalogue. Safety messages follow these words.

WARNING

WARNING (shown above) means that failure to follow the precautions in this message could result in tool failure and serious injury.

NOTICE means that failure to follow the precautions in this message could result in damage to the tool or machine but not result in personal injury.

NOTE and **IMPORTANT** are also used. These are important that you read and follow but are not safety-related.

Visit www.alliedmachine.com for the most up-to-date information and procedures.

Applicable Industries



Aerospace



Agriculture



Automotive



Firearms



General
Machining



Oil & Gas



Renewable
Energy

Reference Icons

The following icons will appear throughout the catalogue to help you navigate between products.

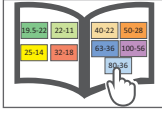

MVS Connection Colour Guide

Detailed instructions and information regarding the MVS connection(s)

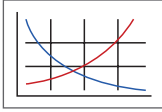

Recommended Cutting Data

Speed and feed recommendations for optimum and safe boring



Through Coolant Option

Indicates that the product is through coolant

Modular Tool Holders Table of Contents

Adapter Side Lock for Cylindrical Shanks	2
Drill Chucks	3
Collet Chucks	4
Milling Machine Arbors	5
Holding Arbors for Milling Cutters	6
Clamping and Tapping Chucks	7
Boring Bar Blanks	8
Accessories for Adapter Sleeves	
Thread Pins and Ball Pressure Screws	9
Adapter Sleeves for Tap Shanks	10
Micro Clamping Chucks	11
Accessories for Drill Chucks	12
Collet Chucks for Erickson System	13
Accessories for Collet Chucks	14 - 27
Collet Set Accessories	28
Accessories for Collet Chucks	29 - 30
Sealing Disks for Collet Chucks	31 - 32
Accessories for Milling Machine Arbors	33
Reducing Sleeves for Hydraulic Clamping Chucks	34
Quick Change Adapters	35 - 38
Service Keys	39

Adapter Side Lock for Cylindrical Shanks DIN 1835B

Clamping Diameter Range: 6.00 mm - 40.00 mm

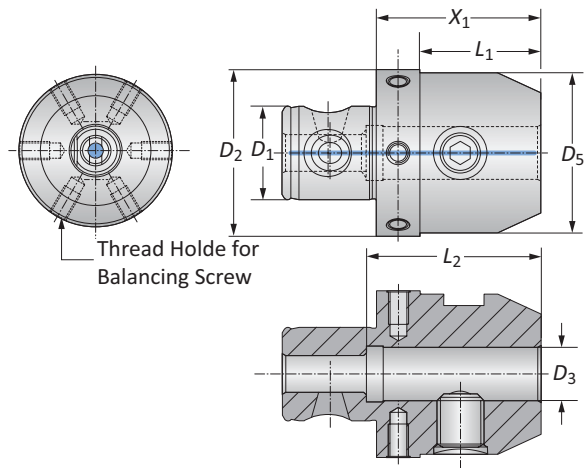

MVS Connection	Clamping Range	Adapter Sleeve				Weight	Balancing Screw	Part No.
		D_2 D_1	D_3	X_1	L_1			
32 - 18	6.00	36.00	23.00	40.00	25.00	0.20 (kg)	M5 x .8 x 6	228022
32 - 18	8.00	36.00	23.00	40.00	28.00	0.20 (kg)	M5 x .8 x 6	228023
32 - 18	10.00	48.00	–	44.00	35.00	0.30 (kg)	M5 x .8 x 6	228024
40 - 22	12.00	52.00	–	49.00	42.00	0.50 (kg)	M5 x .8 x 8	228025
40 - 22	14.00	54.00	–	49.00	44.00	0.60 (kg)	M5 x .8 x 8	228026
50 - 28	6.00	36.00	23.00	40.00	25.00	0.40 (kg)	M6 x 1 x 10	162015
50 - 28	8.00	36.00	23.00	40.00	28.00	0.40 (kg)	M6 x 1 x 10	162016
50 - 28	10.00	44.00	31.00	44.00	35.00	0.50 (kg)	M6 x 1 x 10	162017
50 - 28	12.00	44.00	31.00	49.00	42.00	0.50 (kg)	M6 x 1 x 10	162018
50 - 28	16.00	49.00	36.00	52.00	48.00	1.00 (kg)	M6 x 1 x 10	162019
50 - 28	18.00	49.00	36.00	52.00	48.00	1.00 (kg)	M6 x 1 x 10	228014
50 - 28	20.00	60.00	–	54.00	52.00	1.20 (kg)	M6 x 1 x 10	162020
63 - 36	20.00	49.00	36.00	54.00	52.00	1.10 (kg)	M6 x 1 x 10	161024
63 - 36	25.00	75.00	–	59.00	63.00	1.90 (kg)	M6 x 1 x 15	161026
63 - 36	32.00	75.00	–	63.00	72.00	2.20 (kg)	M6 x 1 x 15	161027
80 - 36	40.00	85.00	–	73.00	80.00	2.50 (kg)	M6 x 1 x 15	161028

NOTE: Balanced 10 gmm/kg

NOTE: When using a ball pressure screw instead of a thread pin, it's similar to DIN 1835E, without axial adjustment.

See ball pressure screws on page B10-I: 9.

B10-M: 12-13

B10: VI-VII

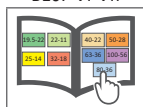
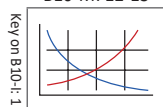

Ⓜ = Metric (mm)

Drill Chucks for Clockwise & Counterclockwise Rotation

Clamping Diameter Range: 0.50 mm - 16.00 mm

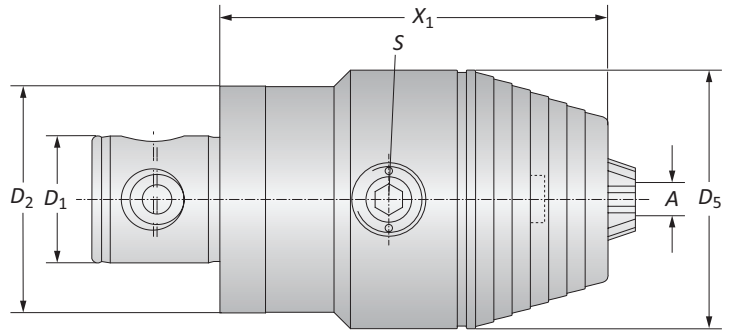

MVS Connection	Clamping Range	Drill Chuck			Weight	Part No.	
		D_2 D_1	A	X_1			D_5
m	50 - 28	0.50 - 13.00	80.00	50.00	s6 / B	1.10 (kg)	209088
	50 - 28	2.50 - 16.00	85.00	57.00	s6 / B	1.30 (kg)	209089
	63 - 36	0.50 - 13.00	80.00	50.00	s6 / B	1.30 (kg)	209090
	63 - 36	2.50 - 16.00	85.00	57.00	s6 / B	1.50 (kg)	209091

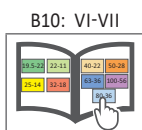
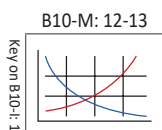

m = Metric (mm)

Collet Chucks ISO 10898 (DIN 6388) | ISO 15488 (DIN 6499)

Clamping Diameter Range: 2.00 mm - 32.00 mm

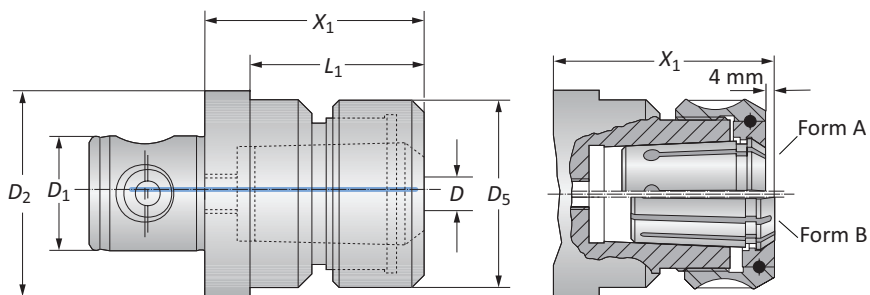

Collet Chucks ISO 10897 (DIN 6388) | Diameter Range: 2.00 mm - 32.00 mm

MVS Connection	Clamping Range	Nominal Size	Collet Chuck			Weight	Part No.	
			D_2 D_1	D	X_1^*			L_1
	40 - 22	2.00 - 16.00	16	64.00	-	43.00	0.50 (kg)	209082
	50 - 28	2.00 - 16.00	16	63.00	50.00	43.00	0.90 (kg)	162011
m	50 - 28	2.00 - 25.00	25	74.00	-	60.00	1.00 (kg)	209083
	63 - 36	2.00 - 25.00	25	74.00	-	60.00	1.40 (kg)	161016
	63 - 36	4.00 - 32.00	32	89.00	-	72.00	1.80 (kg)	161098

* X_1 Clamping nut with ball-bearing

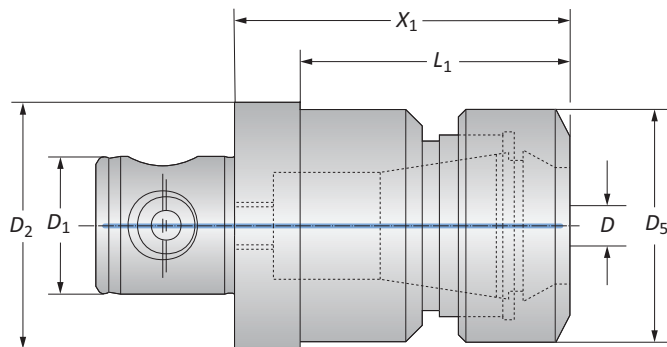

Collet Chucks ISO 15488 (DIN 6499) | Diameter Range: 1.00 mm - 26.00 mm

MVS Connection	Clamping Range	Nominal Size	Collet Chuck			Weight	Part No.	
			D_2 D_1	D	X_1^*			L_1
	32 - 18	1.00 - 10.00	ER 16	54.00	4100	28.00	0.20 (kg)	228020
	40 - 22	2.00 - 16.00	ER 25	75.00	-	42.00	0.60 (kg)	228021
m	50 - 28	2.00 - 16.00	ER 25	75.00	62.00	42.00	0.80 (kg)	228003
	50 - 28	2.00 - 20.00	ER 32	76.00	-	50.00	0.80 (kg)	228004
	63 - 36	2.00 - 20.00	ER 32	76.00	63.00	50.00	1.20 (kg)	228007
	63 - 36	4.00 - 26.00	ER 40	88.00	-	63.00	1.20 (kg)	228006

* X_1 Clamping nut with sliding ring

B10-M: 12-13

B10: VI-VII

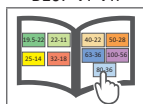
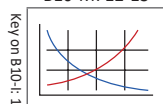

m = Metric (mm)

Milling Machine Arbors

For Milling Cutters with Longitudinal or Transverse Drive | Shell Mill Adapter Range: 13.00 mm - 40.00 mm

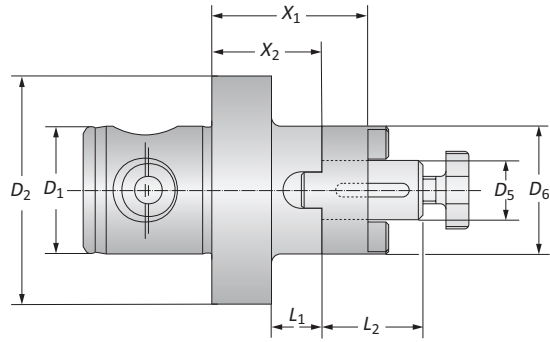

MVS Connection	Adapter Range	Milling Arbor						Weight	Part No.
		D_2 D_1	D_5	X_1	X_2	L_1	L_2		
50 - 28	13.00	34.00	24.00	11.00	22.00	28.00	0.40 (kg)	162002	
50 - 28	16.00	40.00	30.00	17.00	27.00	32.00	0.50 (kg)	162003	
50 - 28	22.00	40.00	28.00	15.00	31.00	40.00	0.60 (kg)	162004	
63 - 36	16.00	40.00	30.00	17.00	27.00	32.00	0.80 (kg)	161002	
63 - 36	22.00	40.00	28.00	15.00	31.00	40.00	0.90 (kg)	161003	
63 - 36	27.00	40.00	28.00	15.00	33.00	48.00	1.10 (kg)	161004	
63 - 36	32.00	40.00	26.00	13.00	38.00	58.00	1.30 (kg)	161005	
80 - 36	40.00	53.00	39.00	-	41.00	70.00*	2.60 (kg)	161006	

* \varnothing 70.00 mm with clutch drive ring

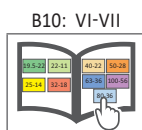
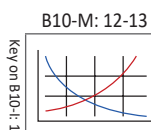

 = Metric (mm)

Holding Arbors for Milling Cutters

Central Coolant Feed | Shell Mill Adapter Range: 16.00 mm - 40.00 mm

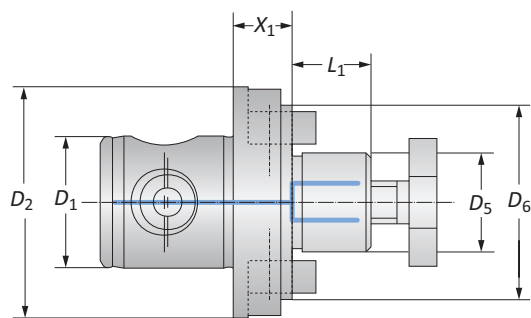
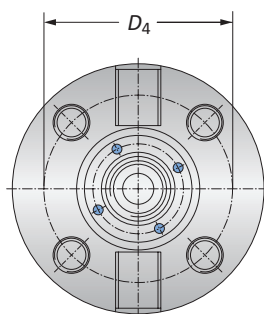

MVS Connection	Adapter Range	Holding Arbor				Weight	Part No.
		D_2 D_1	D_5	X_1	L_1		
50 - 28	16.00	16.00	17.00	–	40.00	0.40 (kg)	162032
50 - 28	22.00	16.00	19.00	–	50.00	0.50 (kg)	162033
m 63 - 36	27.00	16.00	21.00	–	60.00	0.80 (kg)	161082
80 - 36	32.00	16.00	24.00	–	78.00	1.10 (kg)	209080
80 - 36	40.00	19.00	27.00	66.70	89.00	1.50 (kg)	209081

NOTE: See page B10-G: 15 for holding arbor with MVS 100 - 56 connection

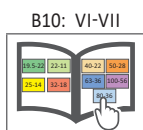
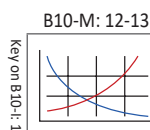

m = Metric (mm)

Clamping Chucks | Tapping Chucks

Clamping Range: 20.00 mm

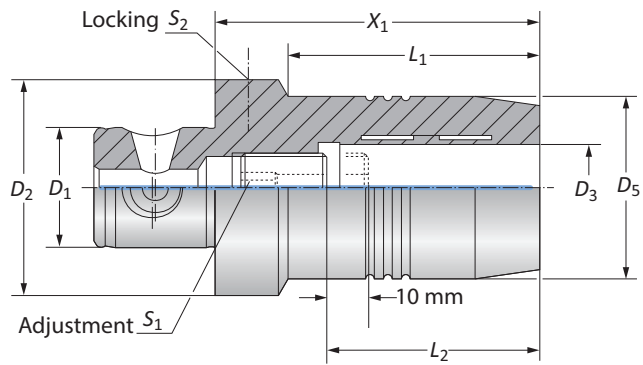

Though Coolant Hydraulic Clamping Chucks

MVS Connection	Clamping Range	Clamping Chucks							Weight	Part No.
		D_2 D_1	D_3	X_1	D_5	L_1	L_2	S_1		
	50 - 28	20.00	75.00	42.00	58.00	51.00	s6	s5	0.80 (kg)	209044
	63 - 36	20.00	75.00	42.00	53.00	51.00	s5	s5	1.10 (kg)	209045

Note: Balanced corresponds to a specific residual imbalance of ≤ 10 gmm/kg.

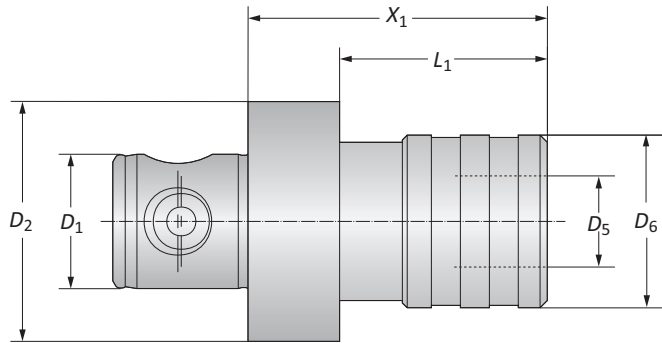

Tapping Chucks (Non-Coolant)

MVS Connection	Quick Change Adapters		Tapping Chucks				Length Compensation		Weight	Part No.	
	For Taps	Nominal Size	X_1	L_1	D_5	D_6	Pressure	Tension			
	50 - 28	M 3 - M 12	1	62.00	49.00	19.00	41.50	7.50	7.50	0.70 (kg)	209098
	50 - 28	M 6 - M 20	2	94.00	-	31.00	60.30	10.00	10.00	1.10 (kg)	209099
	63 - 36	M 3 - M 12	1	56.00	43.00	19.00	41.50	7.50	7.50	0.80 (kg)	231005
	63 - 36	M 6 - M 20	2	80.00	67.00	31.00	60.30	10.00	10.00	1.30 (kg)	231006
	63 - 36	M 14 - M 33	3	152.00	-	48.00	86.00	17.50	17.50	4.10 (kg)	231007

B10-M: 12-13

B10: VI-VII

Key on B10-I-1

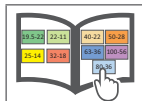
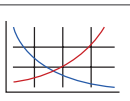

 = Metric (mm)

Boring Bar Blanks

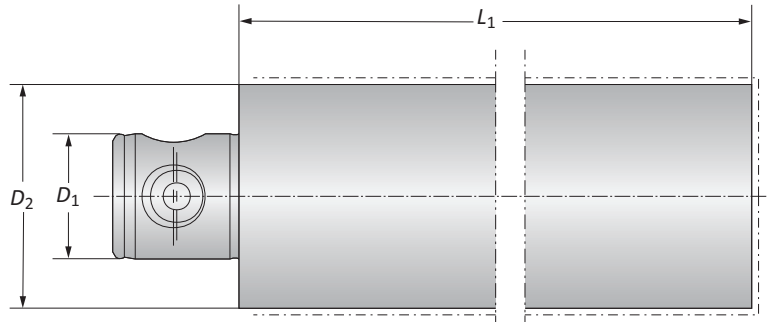

NOTE: The blanks are unhardened and unground in areas marked

MVS Connection	Boring Bar Blanks		
$D_2 D_1$	L_1	Weight	Part No.
50 - 28	160.00	2.60 (kg)	166103
63 - 36	160.00	4.20 (kg)	166104
80 - 36	160.00	6.60 (kg)	166105

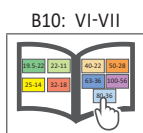
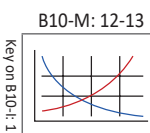

Accessories for Adapter Sleeves

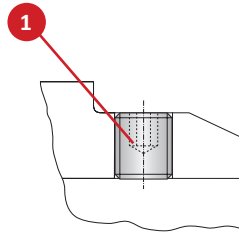
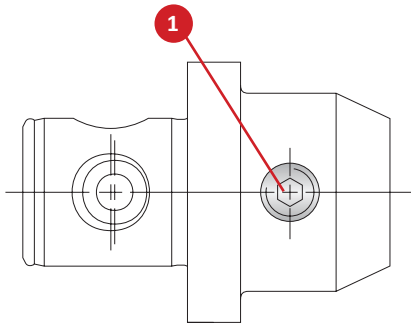

DIN 1835B

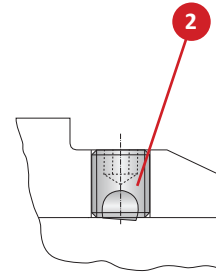

Similar to DIN 1835E*

Clamping Diameter	1 Thread Pin		2 Ball Pressure Screw		
	Part No.	Service Key	Part No.	Service Key	Thread
6.00	115680	s3 / B	315788	s3 / B	M6 x 1
8.00	115681	s4 / B	315789	s4 / B	M8 x 1.25
10.00	115682	s5 / B	515535	s5 / B	M10 x 1.5
12.00	115683	s6 / B	315790	s6 / B	M12 x 1.75
14.00	115683	s6 / B	315790	s6 / B	M12 x 1.75
16.00	115684	s6 / B	515675	s6 / B	M14 x 2
18.00	115684	s6 / B	515675	s6 / B	M14 x 2
20.00	115685	s8 / B	515676	s8 / B	M16 x 2
25.00	115686	s10 / B	515677	s10 / B	M18 x 2 (2x)
32.00	115687	s10 / B	515678	s10 / B	M20 x 2 (2x)
40.00	115687	s10 / B	515678	s10 / B	M20 x 2 (2x)

*Without axial adjustment.

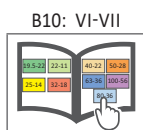
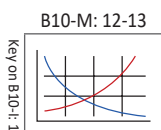

 = Metric (mm)

Accessories for Adapter Sleeves

Adapter Sleeve for Tap Shanks Suitable for Reduction Sleeves with Shanks to DIN 1835-B

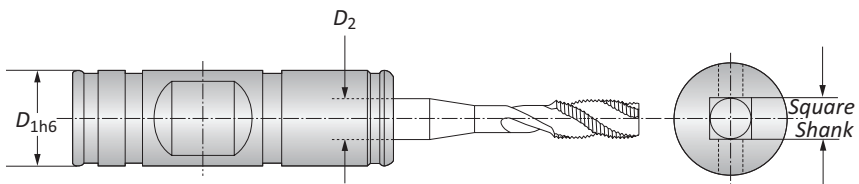

Adapter Sleeves		
D_{1h6}	D_2 x Square Shank	Part No.
8.00	2.10 x 2.50	271190
8.00	2.10 x 2.80	271191
10.00	2.70 x 3.50	271192
10.00	3.00 x 4.00	271193
10.00	3.40 x 4.50	271194
12.00	4.90 x 6.00	271195
14.00	5.50 x 7.00	271196
14.00	6.20 x 8.00	271197
16.00	7.00 x 9.00	271198
16.00	8.00 x 10.00	271199
m 18.00	9.00 x 11.00	271200
20.00	9.00 x 12.00	271201
25.00	11.00 x 14.00	271202
25.00	12.00 x 16.00	271203
32.00	14.50 x 18.00	271204
32.00	16.00 x 20.00	271205
32.00	18.00 x 22.00	271206
40.00	20.00 x 25.00	271207
40.00	22.00 x 28.00	271208
50.00	24.00 x 32.00	271209
50.00	29.00 x 36.00	271210
50.00	32.00 x 40.00	271211

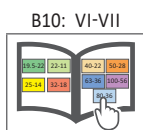
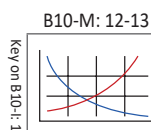

m = Metric (mm)

Accessories for Adapter Sleeves

Adapter Sleeve for Tap Shanks Suitable for Reduction Sleeves with Shanks to DIN 1835-B

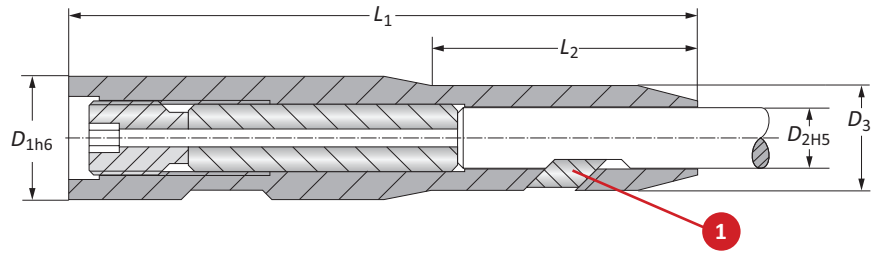

m	Micro Clamping Chucks					1 Clamping Wedge	
	D_{1h6}	D_{2H5}	D_3	L_1	L_2	Part No.	Part No.
	16.00	6.00	12.00	100.00	40.00	219170	219070
	16.00	8.00	14.00	100.00	45.00	219171	219071
	20.00	10.00	17.00	100.00	43.00	219172	219072
	25.00	12.00	20.00	110.00	39.00	219173	219073
	25.00	14.00	22.00	110.00	46.00	219174	219074
	32.00	16.00	25.00	125.00	45.00	219174	219075
	32.00	18.00	27.00	130.00	54.00	219174	219076
	32.00	20.00	30.00	130.00	62.00	219175	219077

NOTE: Clamping chucks are used in reduction sleeves for clamping tools with cylindrical shanks to DIN 1835-B (Fig. 1). The chucks' design allows the use of standard tools versus ordering special tools (Fig. 2).

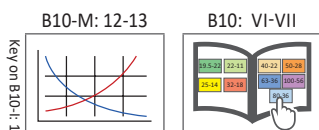
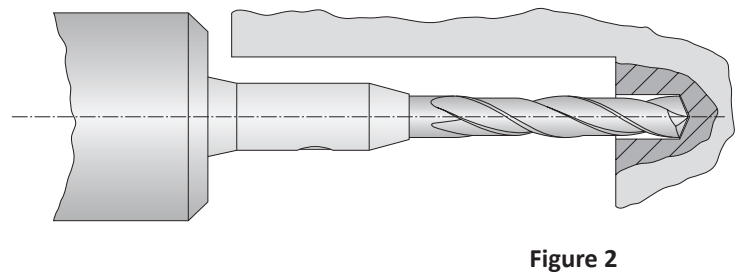
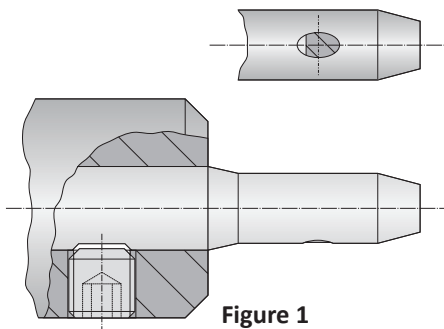

m = Metric (mm)

Accessories for Drill Chucks

Service Keys | Gaskets | Assembly Tool

Service Keys for Drill Chucks

Service Key		Tightening Torque Nm	Part No.
Service Key	Type		
2.50	B	15	415577
6.00	B	15	115578

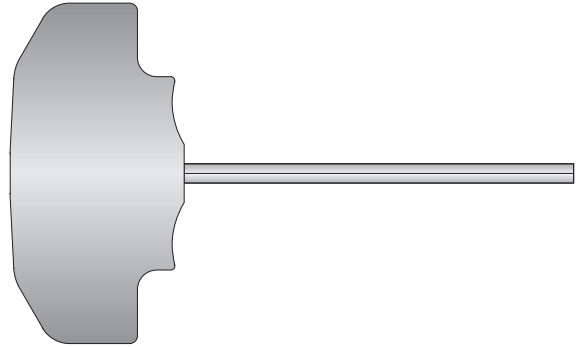

Gaskets for Drill Chucks

	Gasket		Part No.
	Gasket Diameter	Clamping Diameter	
	3.00 - 6.00	0.50 - 13.00	387113
	6.00 - 13.00	0.50 - 13.00	387114
m	3.00 - 6.00	2.50 - 16.00	387115
	6.00 - 16.00	2.50 - 16.00	387116

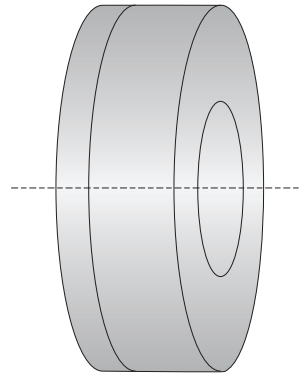

Assembly Tool for Gasket

Part No.
387112

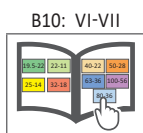
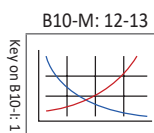
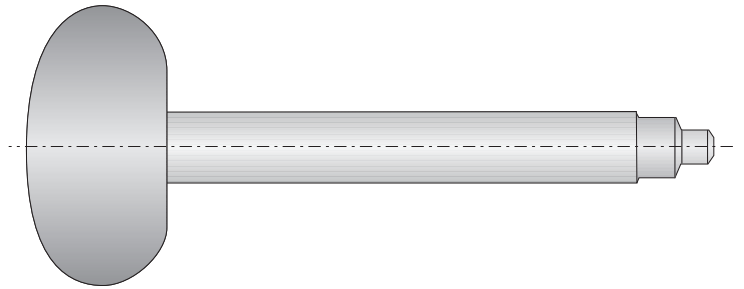

Collet Chucks for Erickson System | Cylindrical Collet Chucks for ISO 15488 (DIN 6499) Collets

Diameter Range: 1.00 mm - 10.00 mm

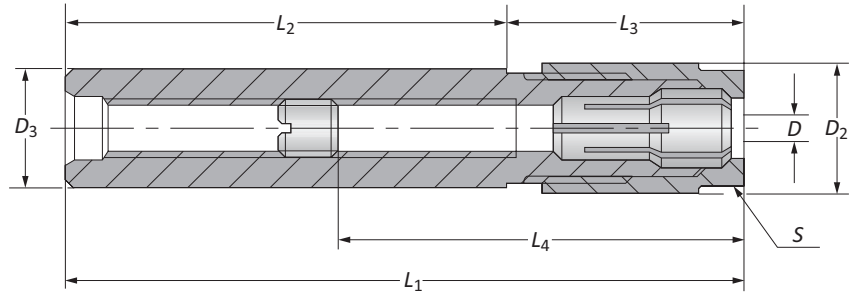

Collet Chucks for Erickson System

Nominal Size	Clamping Range <i>D</i>	Collet Chuck								Service Key <i>S</i>	Weight	Part No.
		<i>D</i> ₂	<i>D</i> ₃	<i>L</i> ₁	<i>L</i> ₂	<i>L</i> ₃	<i>L</i> ₄ Min	<i>L</i> ₄ Max				
m	6	1.00 - 6.50	14.00	12.50	112.00	76.00	36.00	42.00	101.00	13	0.20 (kg)	162080
	6	1.00 - 6.50	14.00	12.50	176.00	140.00	36.00	42.00	102.00	13	0.20 (kg)	162081
	10	1.00 - 10.00	21.00	20.00	120.00	76.00	44.00	39.00	107.00	19	0.30 (kg)	162082
	10	1.00 - 10.00	21.00	20.00	184.00	140.00	44.00	39.00	119.00	19	0.30 (kg)	162083

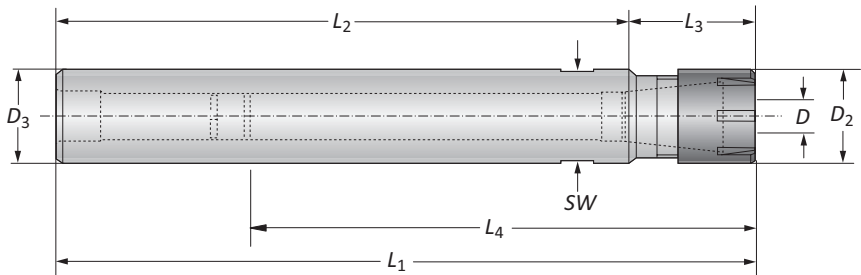

Cylindrical Collet Chucks for ISO 15488 (DIN 6499) Collets

Nominal Size	Collet Chuck									Hex Size <i>SW</i>	Part No.
	<i>D</i>	<i>D</i> ₂	<i>D</i> ₃	<i>L</i> ₁	<i>L</i> ₂	<i>L</i> ₃	<i>L</i> ₄ Min	<i>L</i> ₄ Max			
m	ER 8	1.00 - 5.00	12.00	8.00	126.00	100.00	26.00	36.50	36.50	09	209054
	ER 8	1.00 - 5.00	12.00	12.00	166.00	140.00	26.00	36.50	36.50	09	209055
	ER 11	1.00 - 7.00	16.00	16.00	106.50	80.00	26.50	23.00	65.00	11	209056
	ER 11	1.00 - 7.00	16.00	16.00	166.50	140.00	26.50	23.00	65.00	11	209057
	ER 16	1.00 - 10.00	22.00	20.00	118.50	80.00	38.50	33.00	102.00	17	209058
	ER 16	1.00 - 10.00	22.00	20.00	178.50	140.00	38.50	33.00	123.00	17	209059

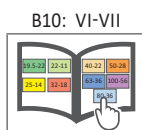
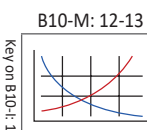

m = Metric (mm)

Accessories for Collet Chucks

Diameter Range: 0.50 mm - 10.00 mm

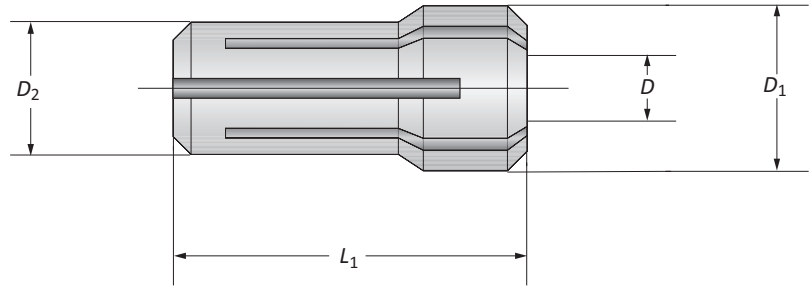

Collet Sets for Erickson System

	Nominal Size	Standard-No.	Set				Part No.
			D_1	D_2	L_1	D	
m	6	416 E	9.50	7.62	25.50	0.50 - 6.00	071016
	10	417 E	13.50	11.43	30.40	0.50 - 10.00	071017

Collets for Erickson System

	Collet	Diameter Range	Part No.
	Nominal Size	D	
m	6	0.50 - 1.00	071355
	6	1.00 - 1.50	071356
	6	1.50 - 2.00	071357
	6	2.00 - 2.50	071358
	6	2.50 - 3.00	071359
	6	3.00 - 3.50	071360
	6	3.50 - 4.00	071361
	6	4.00 - 4.50	071362
	6	4.50 - 5.00	071363
	6	5.00 - 5.50	071364
	6	5.50 - 6.00	071365
	10	0.50 - 1.00	071368
	10	1.00 - 1.50	071369
	10	1.50 - 2.00	071370
	10	2.00 - 2.50	071371
	10	2.50 - 3.00	071372
	10	3.00 - 3.50	071373
	10	3.50 - 4.00	071374
	10	4.00 - 4.50	071375
	10	4.50 - 5.00	071376
10	5.00 - 5.50	071377	
10	5.50 - 6.00	071378	
10	6.00 - 6.50	071379	
10	6.50 - 7.00	071380	
10	7.00 - 7.50	071381	
10	7.50 - 8.00	071382	
10	8.00 - 8.50	071383	
10	8.50 - 9.00	071384	
10	9.00 - 9.50	071385	
10	9.50 - 10.00	071681	

B10-M: 12-13

B10: VI-VII

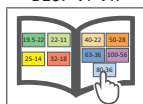
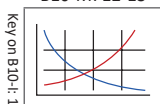

m = Metric (mm)

Accessories for Collet Chucks

ISO 10897-A (DIN 6388-A)

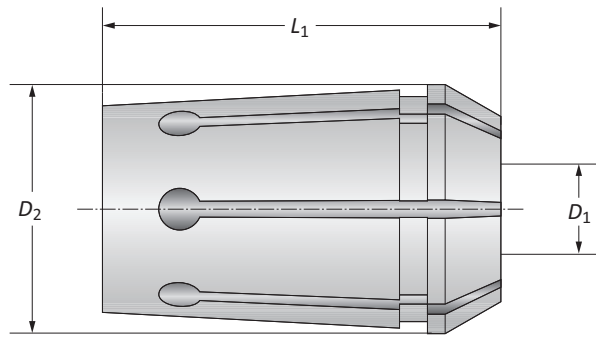
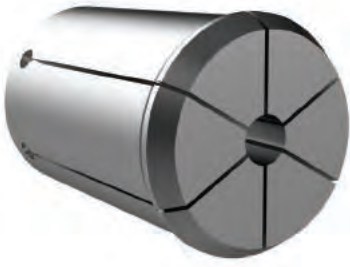

Collet Sets

	Nominal Size	Standard-No.	Set			Part No.
			D_2	L_1	D_1	
m	A 16	410 E	22.65	40.00	2.00 - 16.00	071003
	A 25	444 E	32.90	52.00	2.00 - 25.00	071004
	A 32	450 E	41.30	60.00	4.00 - 32.00	071019

Collets

	Nominal Size	Diameter	
		D_1	Part No.
m	A 16	2.00	071140
	A 16	2.50	071141
	A 16	3.00	071142
	A 16	3.50	071143
	A 16	4.00	071144
	A 16	4.50	071145
	A 16	5.00	071146
	A 16	5.50	071147
	A 16	6.00	071148
	A 16	6.50	071149
	A 16	7.00	071150
	A 16	7.50	071151
	A 16	8.00	071152
	A 16	8.50	071153
	A 16	9.00	071154
	A 16	9.50	071155
	A 16	10.00	071156
	A 16	10.50	071157
	A 16	11.00	071158
	A 16	11.50	071159
	A 16	12.00	071160
	A 16	12.50	071161
	A 16	13.00	071162
	A 16	13.50	071163
	A 16	14.00	071164
	A 16	14.50	071165
	A 16	15.00	071166
	A 16	15.50	071167
A 16	16.00	071168	

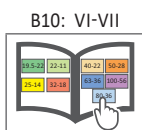
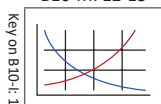

m = Metric (mm)

Accessories for Collet Chucks

ISO 10897-A (DIN 6388-A)

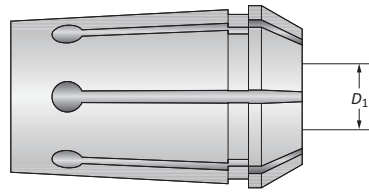

Collets

	Nominal Size	Diameter	
		D_1	Part No.
	A 25	2.00	071169
	A 25	3.00	071170
	A 25	4.00	071171
	A 25	5.00	071172
	A 25	6.00	071173
	A 25	7.00	071174
	A 25	8.00	071175
	A 25	9.00	071176
	A 25	10.00	071177
	A 25	11.00	071178
	A 25	12.00	071179
	A 25	13.00	071180
	A 25	14.00	071181
	A 25	15.00	071182
	A 25	16.00	071183
	A 25	17.00	071184
	A 25	18.00	071185
	A 25	19.00	071186
	A 25	20.00	071187
	A 25	21.00	071188
	A 25	22.00	071189
	A 25	23.00	071190
	A 25	24.00	071191
	A 25	25.00	071192
	A 32	4.00	071612
	A 32	5.00	071419
III	A 32	6.00	071420
	A 32	7.00	071613
	A 32	8.00	071421
	A 32	9.00	071614
	A 32	10.00	071422
	A 32	11.00	071666
	A 32	12.00	071423
	A 32	13.00	071667
	A 32	14.00	071668
	A 32	15.00	071669
	A 32	16.00	071424
	A 32	17.00	071670
	A 32	18.00	071665
	A 32	19.00	071671
	A 32	20.00	071416
	A 32	21.00	071672
	A 32	22.00	071673
	A 32	23.00	071674
	A 32	24.00	071675
	A 32	25.00	071417
	A 32	26.00	071676
	A 32	27.00	071677
	A 32	28.00	071678
	A 32	29.00	071679
	A 32	30.00	071633
	A 32	31.00	071680
	A 32	32.00	071418

Accessories for Collet Chucks

ISO 10897-B (DIN 6388-B)

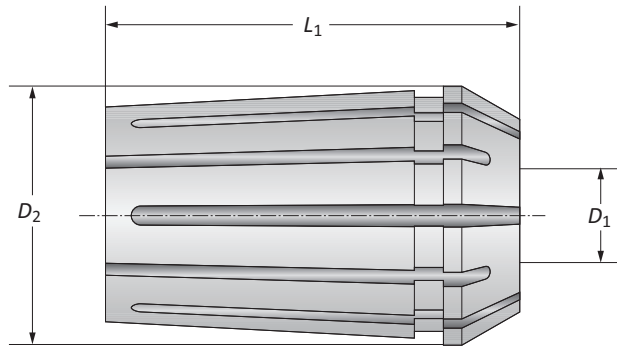

Collet Sets

	Nominal Size	Standard-No.	Set			Part No.
			D_2	L_1	D_1	
m	B 16	415 E	22.65	40.00	1.50 - 16.00	071005
	B 25	462 E	32.90	52.00	3.50 - 25.00	071006
	B 32	467 E	41.30	60.00	5.50 - 32.00	071022

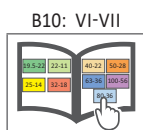
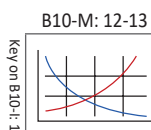

m = Metric (mm)

Accessories for Collet Chucks

ISO 10897-B (DIN 6388-B)

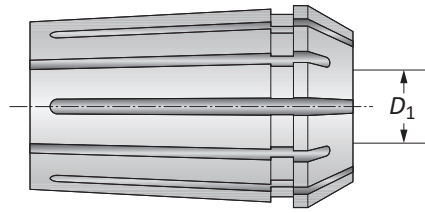

Collets

Nominal Size	Diameter D_1	Part No.
B 25	3.50 - 4.00	071627
B 25	4.00 - 4.50	071628
B 25	4.50 - 5.00	071218
B 25	5.00 - 5.50	071219
B 25	5.50 - 6.00	071220
B 25	6.00 - 6.50	071221
B 25	6.50 - 7.00	071222
B 25	7.00 - 7.50	071223
B 25	7.50 - 8.00	071224
B 25	8.00 - 8.50	071225
B 25	8.50 - 9.00	071226
B 25	9.00 - 9.50	071227
B 25	9.50 - 10.00	071228
B 25	10.00 - 10.50	071229
B 25	10.50 - 11.00	071230
B 25	11.00 - 11.50	071231
B 25	11.50 - 12.00	071232
B 25	12.00 - 12.50	071233
B 25	12.50 - 13.00	071234
B 25	13.00 - 13.50	071235
B 25	13.50 - 14.00	071236
B 25	14.00 - 14.50	071237
B 25	14.50 - 15.00	071238
B 25	15.00 - 15.50	071239
B 25	15.50 - 16.00	071240
B 25	16.00 - 16.50	071241
B 25	16.50 - 17.00	071242
B 25	17.00 - 17.50	071243
B 25	17.50 - 18.00	071244
B 25	18.00 - 18.50	071245
B 25	18.50 - 19.00	071246
B 25	19.00 - 19.50	071247
B 25	19.50 - 20.00	071248
B 25	20.00 - 20.50	071249
B 25	20.50 - 21.00	071250
B 25	21.00 - 21.50	071251
B 25	21.50 - 22.00	071252
B 25	22.00 - 22.50	071253
B 25	22.50 - 23.00	071254
B 25	23.00 - 23.50	071255
B 25	23.50 - 24.00	071256
B 25	24.00 - 24.50	071257
B 25	24.50 - 25.00	071258

mm

B10-M: 12-13

B10: VI-VII

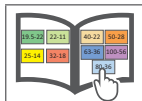
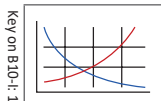

mm = Metric (mm)

Accessories for Collet Chucks

ISO 10897-B (DIN 6388-B)

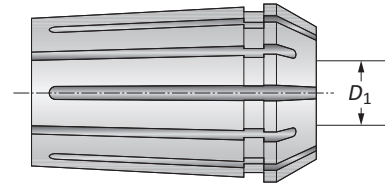

Collets

Nominal Size	Diameter	Part No.
	D_1	
B 32	5.50 - 6.00	071686
B 32	6.00 - 6.50	071687
B 32	6.50 - 7.00	071688
B 32	7.00 - 7.50	071689
B 32	7.50 - 8.00	071690
B 32	8.00 - 8.50	071691
B 32	8.50 - 9.00	071692
B 32	9.00 - 9.50	071693
B 32	9.50 - 10.00	071542
B 32	10.00 - 10.50	071543
B 32	10.50 - 11.00	071544
B 32	11.00 - 11.50	071545
B 32	11.50 - 12.00	071546
B 32	12.00 - 12.50	071547
B 32	12.50 - 13.00	071548
B 32	13.00 - 13.50	071549
B 32	13.50 - 14.00	071550
B 32	14.00 - 14.50	071551
B 32	14.50 - 15.00	071552
B 32	15.00 - 15.50	071553
B 32	15.50 - 16.00	071554
B 32	16.00 - 16.50	071555
B 32	16.50 - 17.00	071556
B 32	17.00 - 17.50	071557
B 32	17.50 - 18.00	071558
B 32	18.00 - 18.50	071559
B 32	18.50 - 19.00	071560
B 32	19.00 - 19.50	071561
B 32	19.50 - 20.00	071562
B 32	20.00 - 20.50	071563
B 32	20.50 - 21.00	071564
B 32	21.00 - 21.50	071565
B 32	21.50 - 22.00	071566
B 32	22.00 - 22.50	071567
B 32	22.50 - 23.00	071568
B 32	23.00 - 23.50	071569
B 32	23.50 - 24.00	071570
B 32	24.00 - 24.50	071571
B 32	24.50 - 25.00	071572
B 32	25.00 - 25.50	071573
B 32	25.50 - 26.00	071574
B 32	26.00 - 26.50	071575
B 32	26.50 - 27.00	071576
B 32	27.00 - 27.50	071577
B 32	27.50 - 28.00	071578
B 32	28.00 - 28.50	071579
B 32	28.50 - 29.00	071580
B 32	29.00 - 29.50	071581
B 32	29.50 - 30.00	071582
B 32	30.00 - 30.50	071583
B 32	30.50 - 31.00	071584
B 32	31.00 - 31.50	071585
B 32	31.50 - 32.00	071586

m

Accessories for Collet Chucks

ISO 10897-A (DIN 6388-A)

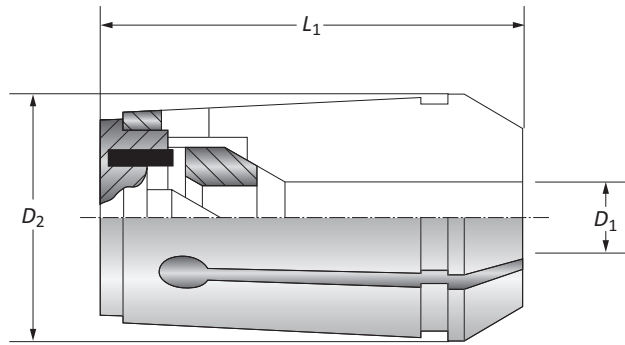
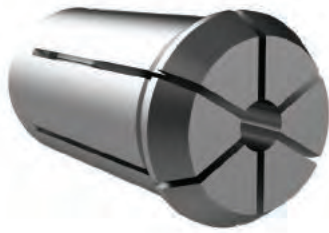

Collet Sets for Clarkson System

	Nominal Size	Standard-No.	Diameter		Part No.
			D_1	D_2	
m	A 16	421 E	6.00 - 12.00	22.65	071013
	A 25	459 E	6.00 - 25.00	32.90	071014
	A 32	460 E	6.00 - 32.00	41.30	071020

NOTE: Recommended to use clamping nuts with ball-bearings to lock collets

Collets for Clarkson System

	Nominal Size	Diameter	
		D_1	Part No.
m	A 16	6.00	071304
	A 16	8.00	071305
	A 16	10.00	071306
	A 16	12.00	071307
	A 25	6.00	071308
	A 25	8.00	071309
	A 25	10.00	071310
	A 25	12.00	071311
	A 25	16.00	071312
	A 25	20.00	071313
	A 25	25.00	071684
	A 32	6.00	071427
	A 32	8.00	071428
	A 32	10.00	071429
	A 32	12.00	071430
	A 32	16.00	071431
	A 32	20.00	071432
	A 32	25.00	071433
	A 32	32.00	071685

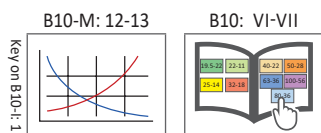

Accessories for Collet Chucks

ISO 15488-B (DIN 6499-B)

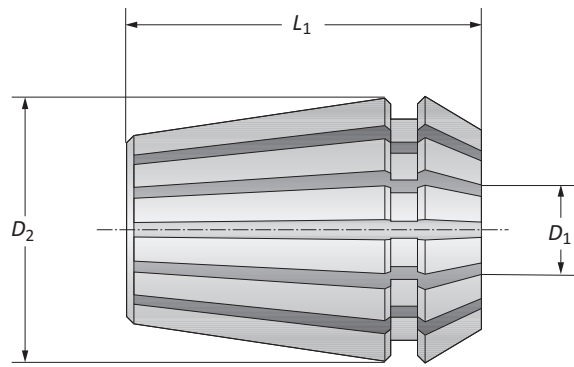

Collet Sets

	Nominal Size	Standard-No.	Diameter		Collet Set		Part No.
			D_1	D_2	L_1		
m	ER 8	4004 E	1.00 - 5.00	8.50	13.50	071034	
	ER 11	4008 E	1.00 - 7.00	11.00	18.00	071028	
	ER 16	426 E	0.50 - 10.00	16.00	27.50	071029	
	ER 25	430 E	1.50 - 16.00	25.00	34.00	071031	
	ER 32	470 E	2.00 - 20.00	32.00	40.00	071032	
	ER 40	472 E	3.00 - 26.00	40.00	46.00	071033	

Collets

	Nominal Size	Diameter		Part No.
		D_1		
m	ER 8	1.00		071986
	ER 8	1.50		071987
	ER 8	2.00		071988
	ER 8	2.50		071989
	ER 8	2.60 - 3.00		071990
	ER 8	3.10 - 3.50		071991
	ER 8	3.60 - 4.00		071992
	ER 8	4.10 - 4.50		071993
	ER 8	4.60 - 5.00		071994
	ER 11	1.00		071700
	ER 11	1.50		071701
	ER 11	2.00		071702
	ER 11	2.50		071703
	ER 11	2.60 - 3.00		071704
	ER 11	3.10 - 3.50		071705
	ER 11	3.60 - 4.00		071706
	ER 11	4.10 - 4.50		071707
	ER 11	4.60 - 5.00		071708
	ER 11	5.10 - 5.50		071709
	ER 11	5.60 - 6.00		071710
ER 11	6.10 - 6.50		071711	
ER 11	6.60 - 7.00		071712	

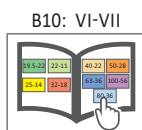
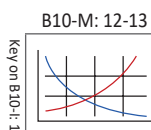

m = Metric (mm)

Accessories for Collet Chucks

ISO 15488-B (DIN 6499-B)

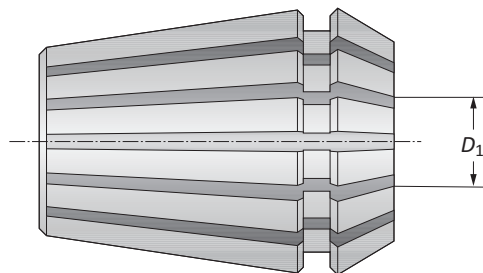

Collets

	Nominal Size	Diameter	
			D_1
	ER 16	0.50 - 1.00	071713
	ER 16	1.00 - 1.50	071714*
	ER 16	1.00 - 2.00	071715
	ER 16	2.00 - 2.50	071716*
	ER 16	2.50 - 3.00	071717
	ER 16	3.00 - 3.50	071718*
	ER 16	3.50 - 4.00	071719
	ER 16	4.00 - 4.50	271132*
m	ER 16	4.00 - 5.00	071720
	ER 16	5.00 - 5.50	271133*
	ER 16	5.50 - 6.00	071721
	ER 16	6.00 - 6.50	271134*
	ER 16	6.00 - 7.00	071722
	ER 16	7.00 - 7.50	271135*
	ER 16	7.5 - 8.00	071723
	ER 16	8.00 - 8.50	271136*
	ER 16	8.50 - 9.00	071724
	ER 16	9.00 - 9.50	271137*
	ER 16	9.00 - 10.00	071725

* Items not contained in set.

B10-M: 12-13

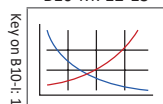

B10: VI-VII

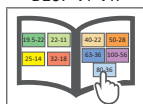







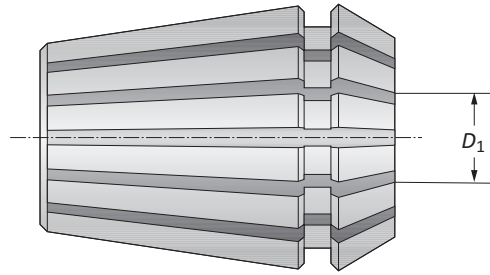













m = Metric (mm)

Accessories for Collet Chucks

ISO 15488-B (DIN 6499-B)



Collets

Nominal Size	Diameter		Part No.
	D_1		
ER 25	1.50 - 2.00		071743
ER 25	2.00 - 2.50		071744*
ER 25	2.50 - 3.00		071745
ER 25	3.00 - 3.50		271128*
ER 25	3.50 - 4.00		071746
ER 25	4.00 - 4.50		271129*
ER 25	4.50 - 5.00		071747
ER 25	5.00 - 5.50		271130*
ER 25	5.50 - 6.00		071748
ER 25	6.00 - 6.50		271131*
ER 25	6.50 - 7.00		071749
ER 25	7.00 - 8.00		071750
ER 25	8.00 - 9.00		071751
ER 25	9.00 - 10.00		071752
ER 25	10.00 - 11.00		071753
ER 25	11.00 - 12.00		071754
ER 25	12.00 - 13.00		071755
ER 25	13.00 - 14.00		071756
ER 25	14.00 - 15.00		071757
ER 25	15.00 - 16.00		071758
 ER 32	2.00 - 3.00		071761
 ER 32	3.00 - 4.00		071762
 ER 32	4.00 - 5.00		071763
 ER 32	5.00 - 6.00		071764
 ER 32	6.00 - 7.00		071765
 ER 32	7.00 - 8.00		071766
 ER 32	8.00 - 9.00		071767
 ER 32	9.00 - 10.00		071768
 ER 32	10.00 - 11.00		071769
 ER 32	11.00 - 12.00		071770
 ER 32	12.00 - 13.00		071771
 ER 32	13.00 - 14.00		071772
 ER 32	14.00 - 15.00		071773
 ER 32	15.00 - 16.00		071774
 ER 32	16.00 - 17.00		071775
 ER 32	17.00 - 18.00		071776
 ER 32	18.00 - 19.00		071777
 ER 32	19.00 - 20.00		071778
 ER 32	17.00 - 18.00		071776
 ER 32	18.00 - 19.00		071777
 ER 32	19.00 - 20.00		071778

* Items not contained in set.

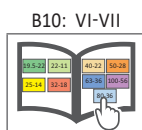
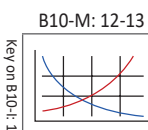

 = Metric (mm)

Accessories for Collet Chucks

ISO 15488-B (DIN 6499-B)

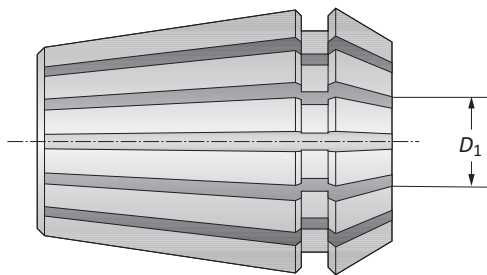

	Nominal Size	Diameter	Part No.
		D_1	
	ER 40	3.00 - 4.00	071779
	ER 40	4.00 - 5.00	071780
	ER 40	5.00 - 6.00	071781
	ER 40	6.00 - 7.00	071782
	ER 40	7.00 - 8.00	071783
	ER 40	8.00 - 9.00	071784
	ER 40	9.00 - 10.00	071785
	ER 40	10.00 - 11.00	071786
	ER 40	11.00 - 12.00	071787
	ER 40	12.00 - 13.00	071788
m	ER 40	13.00 - 14.00	071789
	ER 40	14.00 - 15.00	071790
	ER 40	15.00 - 16.00	071791
	ER 40	16.00 - 17.00	071792
	ER 40	17.00 - 18.00	071793
	ER 40	18.00 - 19.00	071794
	ER 40	19.00 - 20.00	071795
	ER 40	20.00 - 21.00	071796
	ER 40	21.00 - 22.00	071797
	ER 40	22.00 - 23.00	071798
	ER 40	23.00 - 24.00	071799
	ER 40	24.00 - 25.00	071800
	ER 40	25.00 - 26.00	071801

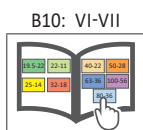
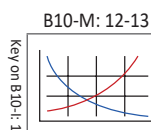

m = Metric (mm)

Collet Sets for Taps DIN 371/374/376

ISO 15488-B (DIN 6499-B)

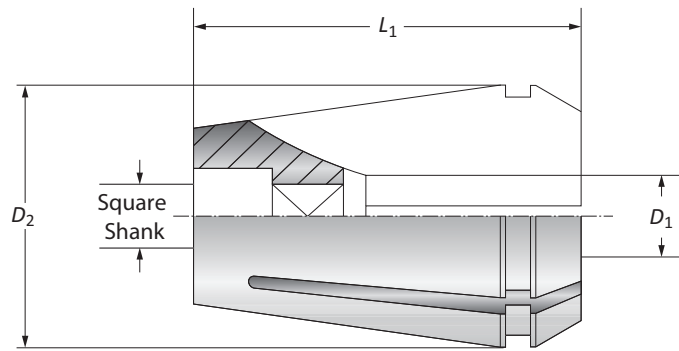

Collet Sets

	Nominal Size	Standard-No.	Clamping Range D_1	Collet Set		Part No.
				D_2	L_1	
m	ER 16	426 EGB	4.50 - 7.00	16.00	27.50	071045
	ER 25	430 EGB	4.50 - 12.00	25.00	34.00	071047
	ER 32	470 EGB	4.50 - 16.00	32.00	40.00	071048
	ER 40	472 EGB	7.00 - 20.00	40.00	46.00	071049

NOTE: To lock these collets, we recommend using the clamping nuts with sliding ring for higher clamping forces.

Taps

	Shank		Tap		
	D_1	Square Shank	DIN 371	DIN 374	DIN 376
m	4.50	3.40	M 4	M 6 x...	M 6
	5.50	4.30	-	M 7 x...	M 7
	6.00	4.90	M 4,5/5/6	M 8 x...	M 8
	7.00	5.50	M 7	M 9/10 x...	M 9/10
	8.00	6.20	M 8	M 6 x...	M 11
	9.00	7.00	M 9	M 6 x...	M 12
	10.00	8.00	M 10	-	-
	11.00	9.00	-	M 14 x...	M 14
	12.00	9.00	M 12	M 16 x...	M 16
	14.00	11.00	-	M 18 x...	M 18
	16.00	12.00	-	M 20 x...	M 20
	18.00	14.00	-	M 22/24 x...	M 22/24
	20.00	16.00	-	M 27 x...	M 27

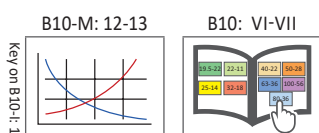

m = Metric (mm)

Accessories for Collet Sets for Taps DIN 371/374/376

ISO 15488-B (DIN 6499-B)

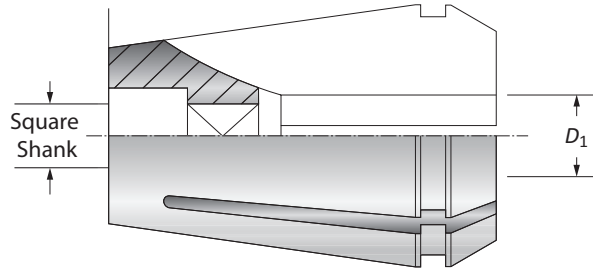

Nominal Size	Suitable Taps		Part No.
	D_1	Square Shank	
ER 16	4.50	3.40	071901
ER 16	5.50	4.30	071902
ER 16	6.00	4.90	071903
ER 16	7.00	5.50	071904
ER 25	4.50	3.40	071912
ER 25	5.50	4.30	071913
ER 25	6.00	4.90	071914
ER 25	7.00	5.50	071915
ER 25	8.00	6.20	071916
ER 25	9.00	7.00	071917
ER 25	10.00	8.00	071918
ER 25	11.00	9.00	071919
ER 25	12.00	9.00	071920
ER 32	4.50	3.40	071921
ER 32	5.50	4.30	071922
ER 32	6.00	4.90	071923
ER 32	7.00	5.50	071924
ER 32	8.00	6.20	071925
ER 32	9.00	7.00	071926
ER 32	10.00	8.00	071927
ER 32	11.00	9.00	071928
ER 32	12.00	9.00	071929
ER 32	14.00	11.00	071930
ER 32	16.00	12.00	071931
ER 40	7.00	5.50	071932
ER 40	8.00	6.20	071933
ER 40	9.00	7.00	071934
ER 40	10.00	8.00	071935
ER 40	11.00	9.00	071936
ER 40	12.00	9.00	071937
ER 40	14.00	11.00	071938
ER 40	16.00	12.00	071939
ER 40	18.00	14.50	071940
ER 40	20.00	16.00	071941

Ⓜ

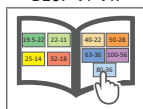
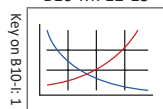

Ⓜ = Metric (mm)

Accessories for Collet Chucks: ISO 15488-B (DIN 6499-B)

Collets

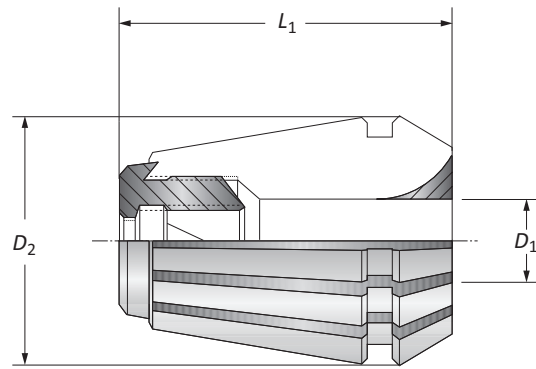

Collets for Mill Cutters with Pull Thread System

	Nominal Size	Standard-No.	Clamping Range D_2	Collet		Part No.
				L_1	D_1	
Ⓜ	ER 32	470 ECL	32.00	46.00	6.00 - 16.00	071052
	ER 40	472 ECL	40.00	52.00	6.00 - 25.00	071053

Collets

	Collet		Part No.
	Nominal Size	D_1	
Ⓜ	ER 32	6.00	071826
	ER 32	8.00	071827
	ER 32	10.00	071828
	ER 32	12.00	071829
	ER 32	16.00	071830
	ER 40	6.00	071831
	ER 40	8.00	071832
	ER 40	10.00	071833
	ER 40	12.00	071834
	ER 40	16.00	071835
	ER 40	20.00	071836
	ER 40	25.00	071837

NOTE: To lock these collets, we recommend using the clamping nuts with sliding ring for higher clamping forces.

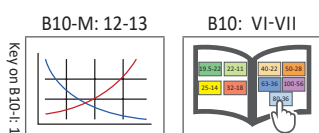

Ⓜ = Metric (mm)

Collet Kit Set Accessories for Collet Chucks



Collet Kits: ISO 15488 (DIN 6499)

Nominal Size	Kit				Collet Space	Kit Part No.
	Width	Depth	Height			
ER 16	140.00	72.00	45.00		10.00	099049
ER 25	196.00	112.00	50.00		15.00	099050
ER 32	251.00	140.00	56.00		18.00	099051

Collet Kits: ISO 10897 (DIN 6388)

Nominal Size	Kit				Collet Space	Kit Part No.
	Width	Depth	Height			
ER 16	226.00	161.00	85.00		15.00	099053
ER 25	333.00	201.00	85.00		24.00	099054
ER 32	320.00	210.00	85.00		15.00	099055

B10-M: 12-13

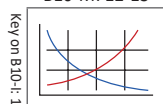

B10: VI-VII

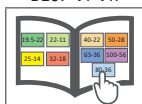

Accessories for Collet Chucks: ISO 10897 (DIN 6388)

Clamping Nuts

Clamping Nuts: DIN 6388 / ISO 10897 - 1:10

		Clamping Nut				
	Nominal Size	D_1	L_1	Clamping Range	Torque	Part No.
	16	43.00	24.00	2.00 - 16.00	100 Nm	068048
	25	60.00	30.00	2.00 - 25.00	180 Nm	068052
	32	72.00	33.50	4.00 - 32.00	220 Nm	161099

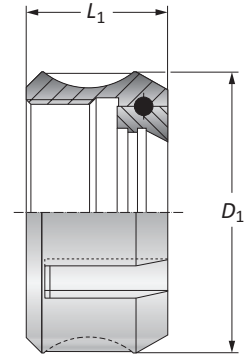

Clamping Nuts for Sealing Discs: DIN 6388 / ISO 10897 - 1:10

		Clamping Nut				
	Nominal Size	D_1	L_1	Clamping Range	Torque	Part No.
	16	43.00	31.50	2.00 - 16.00	100 Nm	275001
	25	60.00	38.00	2.00 - 25.00	180 Nm	275003
	32	72.00	42.00	4.00 - 32.00	220 Nm	276001

NOTE: with ball-bearing, for use with sealing discs

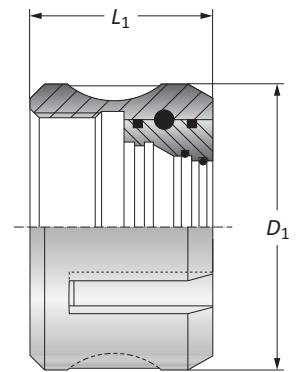

Mini Clamping Nuts

		Clamping Nut				
	Nominal Size	D_1	L_1	Clamping Range	Torque	Part No.
	ER 08	12.00	10.80	1.00 - 4.00	8 Nm	415357
	ER 11	16.00	12.00	1.00 - 7.00	16 Nm	415358
	ER 16	22.00	18.00	1.00 - 10.00	25 Nm	415359

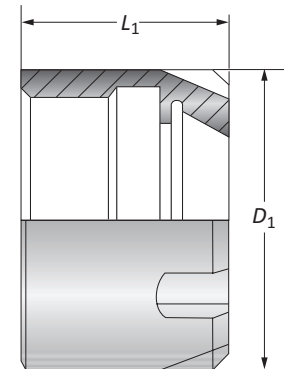

Clamping Nuts for Erickson Collet Chuck System

		Clamping Nut			
	Nominal Size	D_1	L_1	Clamping Range	Part No.
	6	14.00	28.00	1.00 - 6.50	162095
	10	21.00	36.00	1.00 - 10.00	162093

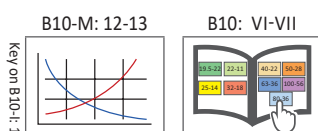
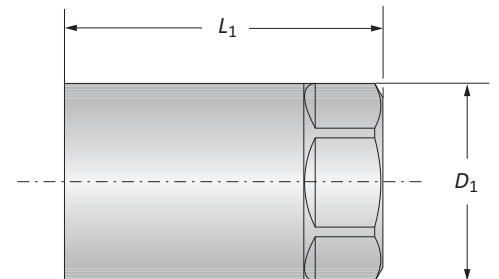

 = Metric (mm)

Accessories for Collet Chucks: ISO 15488 (DIN 6499)

Clamping Nuts

One Piece Clamping Nuts: DIN 6499 / ISO 15488 - 8°

	Nominal Size	Clamping Nut				Part No.
		D_1	L_1	Clamping Range	Torque	
m	ER 16	28.00	17.50	1.00 - 10.00	60 Nm	215922
	ER 25	42.00	20.00	2.00 - 16.00	100 Nm	215924
	ER 32	50.00	22.50	2.00 - 20.00	140 Nm	215925
	ER 40	63.00	25.50	4.00 - 26.00	180 Nm	215926

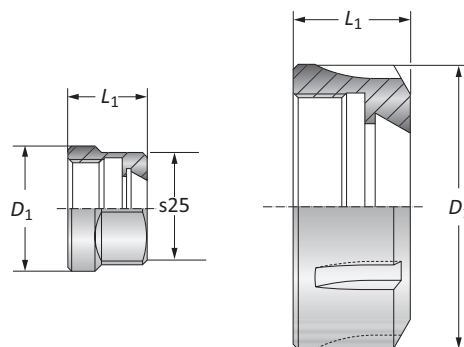

Clamping Nuts with Sliding Ring: DIN 6499 / ISO 15488 - 8°

	Nominal Size	Clamping Nut				Part No.
		D_1	L_1	Clamping Range	Torque	
m	ER 16	28.00	20.30	1.00 - 10.00	60 Nm	315015
	ER 25	42.00	22.40	2.00 - 16.00	100 Nm	315016
	ER 32	50.00	25.00	2.00 - 20.00	140 Nm	315017
	ER 40	63.00	28.30	4.00 - 26.00	180 Nm	315018

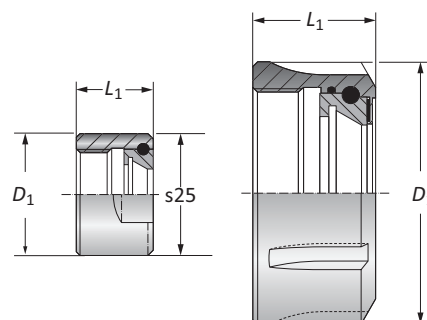

One Piece Clamping Nuts for use with Sealing Disks: DIN 6499 / ISO 15488 - 8°

	Nominal Size	Clamping Nut				Part No.
		D_1	L_1	Clamping Range	Torque	
m	ER 16	28.00	25.00	1.00 - 10.00	60 Nm	277001
	ER 25	42.00	27.50	2.00 - 16.00	100 Nm	277005
	ER 32	50.00	30.50	2.00 - 20.00	140 Nm	277007
	ER 40	63.00	34.00	4.00 - 26.00	180 Nm	278001

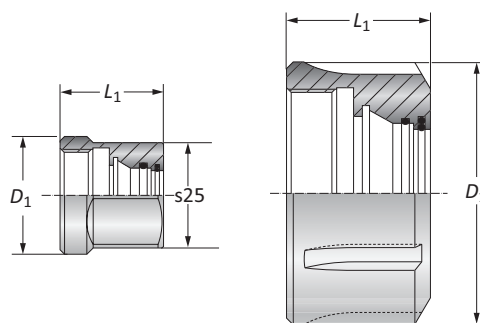

Clamping Nuts with Sliding Ring for use with Sealing Disks: DIN 6499 / ISO 15488 - 8°

	Nominal Size	Clamping Nuts: ISO 15488 (DIN 6499)				Part No.
		D_1	L_1	Clamping Range	Torque	
m	ER 16	28.00	25.00	1.00 - 10.00	60 Nm	277002
	ER 25	42.00	28.50	2.00 - 16.00	100 Nm	277006
	ER 32	50.00	31.50	2.00 - 20.00	140 Nm	277008
	ER 40	63.00	35.00	4.00 - 26.00	180 Nm	278002

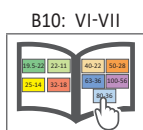
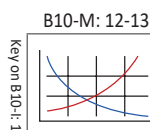
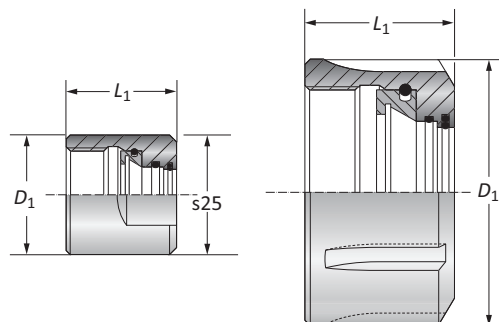

Sealing Disks for Collet Chucks: ISO 10897 (DIN 6388)

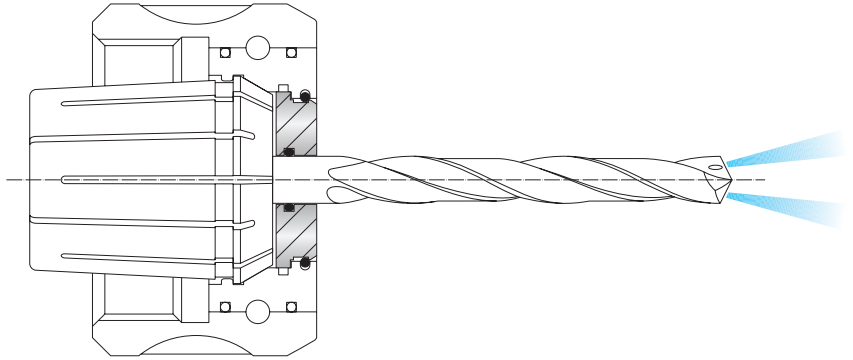

Nominal Size	Sealing Disk		Sealing Disk		Sealing Disk		Sealing Disk	
	Diameter	Part No.	Diameter	Part No.	Diameter	Part No.	Diameter	Part No.
16	2.50 - 3.00	275010	6.00 - 6.50	275017	9.50 - 10.00	275024	13.00 - 13.50	275031
16	3.00 - 3.50	275011	6.50 - 7.00	275018	10.00 - 10.50	275025	13.50 - 14.00	275032
16	3.50 - 4.00	275012	7.00 - 7.50	275019	10.50 - 11.00	275026	14.00 - 14.50	275033
16	4.00 - 4.50	275013	7.50 - 8.00	275020	11.00 - 11.50	275027	14.50 - 15.00	275034
16	4.50 - 5.00	275014	8.00 - 8.50	275021	11.50 - 12.00	275028	15.00 - 15.50	275035
16	5.00 - 5.50	275015	8.50 - 9.00	275022	12.00 - 12.50	275029	15.50 - 16.00	275036
16	5.50 - 6.00	275016	9.00 - 9.50	275023	12.50 - 13.00	275030	–	–
25	2.50 - 3.00	275040	8.50 - 9.00	275052	14.50 - 15.00	275064	20.50 - 21.00	275076
25	3.00 - 3.50	275041	9.00 - 9.50	275053	15.00 - 15.50	275065	21.00 - 21.50	275077
25	3.50 - 4.00	275042	9.50 - 10.00	275054	15.50 - 16.00	275066	21.50 - 22.00	275078
25	4.00 - 4.50	275043	10.00 - 10.50	275055	16.00 - 16.50	275067	22.00 - 22.50	275079
25	4.50 - 5.00	275044	10.50 - 11.00	275056	16.50 - 17.00	275068	22.50 - 23.00	275080
25	5.00 - 5.50	275045	11.00 - 11.50	275057	17.00 - 17.50	275069	23.00 - 23.50	275081
25	5.50 - 6.00	275046	11.50 - 12.00	275058	17.50 - 18.00	275070	23.50 - 24.00	275082
25	6.00 - 6.50	275047	12.00 - 12.50	275059	18.00 - 18.50	275071	24.00 - 24.50	275083
25	6.50 - 7.00	275048	12.50 - 13.00	275060	18.50 - 19.00	275072	24.50 - 25.00	275084
m 25	7.00 - 7.50	275049	13.00 - 13.50	275061	19.00 - 19.50	275073	–	–
25	7.50 - 8.00	275050	13.50 - 14.00	275062	19.50 - 20.00	275074	–	–
25	8.00 - 8.50	275051	14.00 - 14.50	275063	20.00 - 20.50	275075	–	–
32	3.50 - 4.00	276005	11.00 - 11.50	276020	18.50 - 19.00	276035	26.00 - 26.50	276050
32	4.00 - 4.50	276006	11.50 - 12.00	276021	19.00 - 19.50	276036	26.50 - 27.00	276051
32	4.50 - 5.00	276007	12.00 - 12.50	276022	19.50 - 20.00	276037	27.50 - 28.00	276052
32	5.00 - 5.50	276008	12.50 - 13.00	276023	20.00 - 20.50	276038	27.50 - 28.00	276053
32	5.50 - 6.00	276009	13.00 - 13.50	276024	20.50 - 21.00	276039	28.00 - 28.50	276054
32	6.00 - 6.50	276010	13.50 - 14.00	276025	21.00 - 21.50	276040	28.50 - 29.00	276055
32	6.50 - 7.00	276011	14.00 - 14.50	276026	21.50 - 22.00	276041	29.00 - 29.50	276056
32	7.00 - 7.50	276012	14.50 - 15.00	276027	22.00 - 22.50	276042	29.50 - 30.00	276057
32	7.50 - 8.00	276013	15.00 - 15.50	276028	22.50 - 23.00	276043	30.00 - 30.50	276058
32	8.00 - 8.50	276014	15.50 - 16.00	276029	23.00 - 23.50	276044	30.50 - 31.00	276059
32	8.50 - 9.00	276015	16.00 - 16.50	276030	23.50 - 24.00	276045	31.00 - 31.50	276060
32	9.00 - 9.50	276016	16.50 - 17.00	276031	24.00 - 24.50	276046	31.50 - 32.00	276061
32	9.50 - 10.00	276017	17.00 - 17.50	276032	24.50 - 25.00	276047	–	–
32	10.00 - 10.50	276018	17.50 - 18.00	276033	25.00 - 25.50	276048	–	–
32	10.50 - 11.00	276019	18.00 - 18.50	276034	25.50 - 26.00	276049	–	–

m

B10-M: 12-13

B10: VI-VII

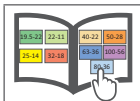
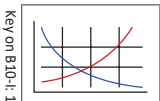

m = Metric (mm)

Sealing Disks Collet Chucks: ISO 15488 (DIN 6499)

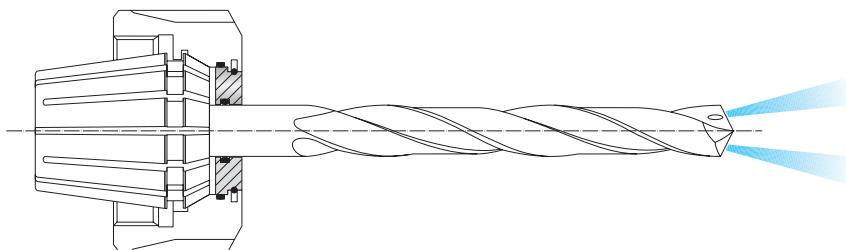

Nominal Size	Sealing Disk		Sealing Disk		Sealing Disk		Sealing Disk	
	Diameter	Part No.	Diameter	Part No.	Diameter	Part No.	Diameter	Part No.
ER 16	2.50 - 3.00	277010	4.50 - 5.00	277014	6.50 - 7.00	277018	8.50 - 9.00	277022
ER 16	3.00 - 3.50	277011	5.00 - 5.50	277015	7.00 - 7.50	277019	9.00 - 9.50	277023
ER 16	3.50 - 4.00	277012	5.50 - 6.00	277016	7.50 - 8.00	277020	9.50 - 10.00	277024
ER 16	4.00 - 4.50	277013	6.00 - 6.50	277017	8.00 - 8.50	277021	–	–
ER 25	2.50 - 3.00	277025	6.00 - 6.50	277032	9.50 - 10.00	277039	13.00 - 13.50	277046
ER 25	3.00 - 3.50	277026	6.50 - 7.00	277033	10.00 - 10.50	277040	13.50 - 14.00	277047
ER 25	3.50 - 4.00	277027	7.00 - 7.50	277034	10.50 - 11.00	277041	14.00 - 14.50	277048
ER 25	4.00 - 4.50	277028	7.50 - 8.00	277035	11.00 - 11.50	277042	14.50 - 15.00	277049
ER 25	4.50 - 5.00	277029	8.00 - 8.50	277036	11.50 - 12.00	277043	15.00 - 15.50	277050
ER 25	5.00 - 5.50	277030	8.50 - 9.00	277037	12.00 - 12.50	277044	15.50 - 16.00	277051
ER 25	5.50 - 6.00	277031	9.00 - 9.50	277038	12.50 - 13.00	277045	–	–
ER 32	2.50 - 3.00	277055	7.00 - 7.50	277064	11.50 - 12.00	277073	16.00 - 16.50	277082
ER 32	3.00 - 3.50	277056	7.50 - 8.00	277065	12.00 - 12.50	277074	16.50 - 17.00	277083
ER 32	3.50 - 4.00	277057	8.00 - 8.50	277066	12.50 - 13.00	277075	17.00 - 17.50	277084
ER 32	4.00 - 4.50	277058	8.50 - 9.00	277067	13.00 - 13.50	277076	17.50 - 18.00	277085
ER 32	4.50 - 5.00	277059	9.00 - 9.50	277068	13.50 - 14.00	277077	18.00 - 18.50	277086
ER 32	5.00 - 5.50	277060	9.50 - 10.00	277069	14.00 - 14.50	277078	18.50 - 19.00	277087
ER 32	5.50 - 6.00	277061	10.00 - 10.50	277070	14.50 - 15.00	277079	19.00 - 19.50	277088
ER 32	6.00 - 6.50	277062	10.50 - 11.00	277071	15.00 - 15.50	277080	19.50 - 20.00	277089
ER 32	6.50 - 7.00	277063	11.00 - 11.50	277072	15.50 - 16.00	277081	–	–
ER 40	2.50 - 3.00	278005	8.50 - 9.00	278017	14.50 - 15.00	278029	20.50 - 21.00	278041
ER 40	3.00 - 3.50	278006	9.00 - 9.50	278018	15.00 - 15.50	278030	21.00 - 21.50	278042
ER 40	3.50 - 4.00	278007	9.50 - 10.00	278019	15.50 - 16.00	278031	21.50 - 22.00	278043
ER 40	4.00 - 4.50	278008	10.00 - 10.50	278020	16.00 - 16.50	278032	22.00 - 22.50	278044
ER 40	4.50 - 5.00	278009	10.50 - 11.00	278021	16.50 - 17.00	278033	22.50 - 23.00	278045
ER 40	5.00 - 5.50	278010	11.00 - 11.50	278022	17.00 - 17.50	278034	23.00 - 23.50	278046
ER 40	5.50 - 6.00	278011	11.50 - 12.00	278023	17.50 - 18.00	278035	23.50 - 24.00	278047
ER 40	6.00 - 6.50	278012	12.00 - 12.50	278024	18.00 - 18.50	278036	24.00 - 24.50	278048
ER 40	6.50 - 7.00	278013	12.50 - 13.00	278025	18.50 - 19.00	278037	24.50 - 25.00	278049
ER 40	7.00 - 7.50	278014	13.00 - 13.50	278026	19.00 - 19.50	278038	25.00 - 25.50	278050
ER 40	7.50 - 8.00	278015	13.50 - 14.00	278027	19.50 - 20.00	278039	25.50 - 26.00	278051
ER 40	8.00 - 8.50	278016	14.00 - 14.50	278028	20.00 - 20.50	278040	–	–

m

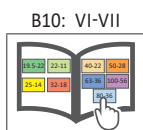
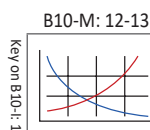

m = Metric (mm)

A
B
C
D
E
F
G
H
I
J
K
L
M
INDEX

Accessories for Milling Machine Arbors

Accessories for Milling Machine Arbors

Shell-Mill Adapter	Part No.		
	1 Clutch Drive Ring	2 Axial Drive Key	3 Retaining Screw
13	115708	115709	115707
16	115696	215608	115697
22	115341	215609	115345
27	115342	215610	115346
32	115343	215611	115347
40	115344	215612	115348

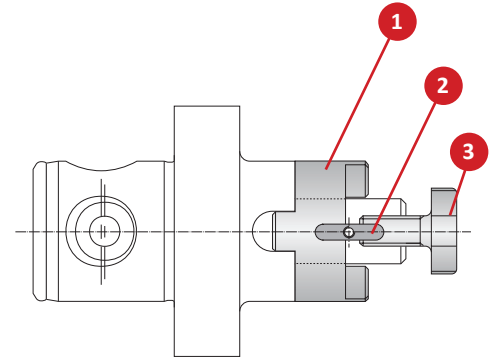

Accessories for Milling Machine Arbors

Shell-Mill Adapter	Part No.		
	1 Drive Key	2 Cap Screw	3 Retaining Screw
16	215701	115566	115697
22	215702	108109	115345
27	215703	109109	115346
32	215704	115147	115347
40	215705	116152	115348
60	115643	115237	-

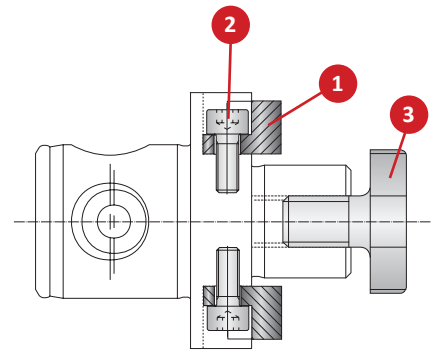

Accessories for Holding Arbors

Adapter Sleeves	Part No.	
	1 Cap Screw	Service Key
209022	115929	s5
209023	115930	s7
209024	115932	s8
209025	115933	s5
209026	115169	s8
209027	115934	s10
209028	115936	s12

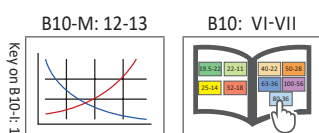
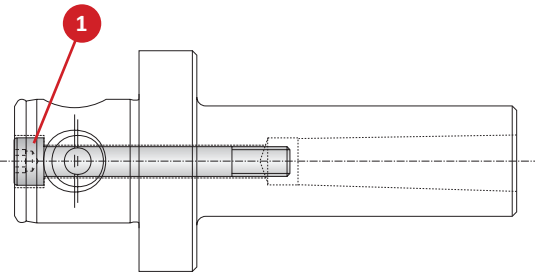

Key on B10-I-1

m = Metric (mm)

Reducing Sleeves for Hydraulic Clamping Chucks

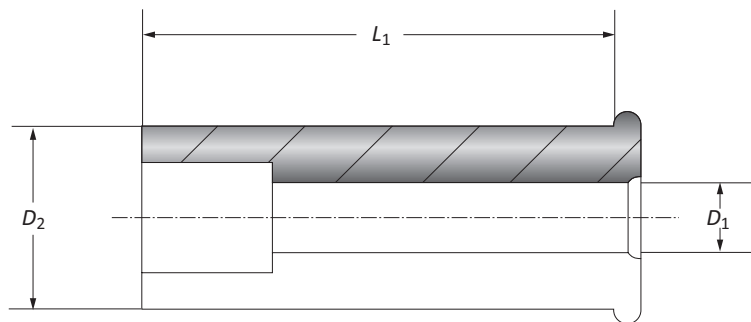

	Nominal Size	Reducing Sleeve		Part No.
	D_2	D_1	L_1	
m	20.00	3.00	50.50	271045
	20.00	4.00	50.50	271046
	20.00	5.00	50.50	271047
	20.00	6.00	50.50	271070
	20.00	7.00	50.50	271049
	20.00	8.00	50.50	271004
	20.00	9.00	50.50	271050
	20.00	10.00	50.50	271005
	20.00	11.00	50.50	271051
	20.00	12.00	50.50	271073
	20.00	13.00	50.50	271052
	20.00	14.00	50.50	271074
	20.00	15.00	50.50	271018
	20.00	16.00	50.50	271008

NOTE: For cylindrical shanks with shank tolerance h6 for clamping diameter 3 mm and 8 mm and with shank tolerance h7 for clamping diameter 10 mm - 32 mm.
NOTE: Reduction sleeve with adjustable stop.

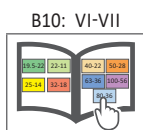
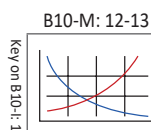

m = Metric (mm)

Quick Change Adapters

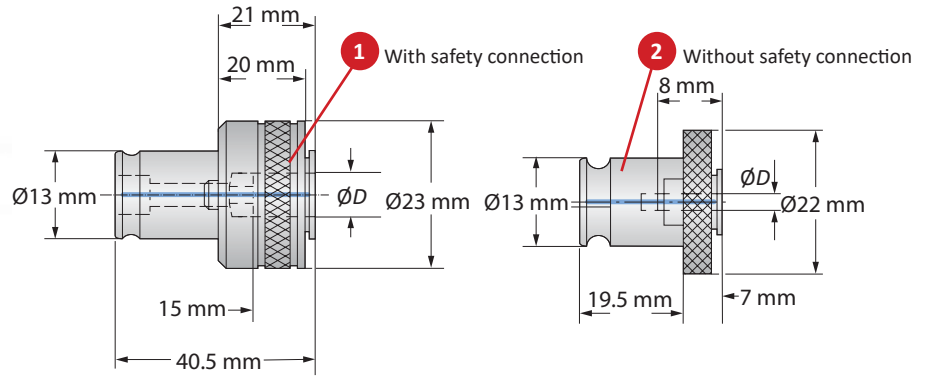

Shank Dimensions		Quick Change Adapter								Part No.	
Nominal Size	D x Square Shank	DIN 352	DIN 353	DIN 371	DIN 374	DIN 376	DIN 2182	DIN 2183	Torque Setting	1	2
0	2.10 x 2.50	M 1	-	M 1	-	M 3.5	1/16"	-	1.5 - 2	233070	K24358
0	2.10 x 2.80	M 2	-	M 2	M 4	M 4	3/32"	5/32"	2 - 3	233071	K24276
0	2.70 x 3.50	M 3	-	M 3	M 5	M 5	1/8"	-	4 - 6	233072	K24277
0	3.00 x 4.00	M 3.5	-	M 3.5	-	-	-	-	1.5 - 2	233073	K24278
0	3.40 x 4.50	M 4	-	M 4	M 6	M 6	5/32"	1/4"	6 - 9	233074	K24279
0	4.90 x 6.00	M 8	-	-	M 8	M 8	-	-	16 - 21	233075	K24280
0	5.50 x 7.00	M 10	G 1/8"	-	M 10	M 10	1/4"	3/8"	27 - 32	233076	K24281
0	6.20 x 8.00	-	-	M 8	-	-	5/16"	7/16"	16 - 21	233077	K24391

NOTE: Quick change adapters are typically set to the torque value shown in the table.

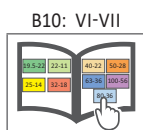
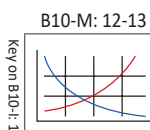

Quick Change Adapters

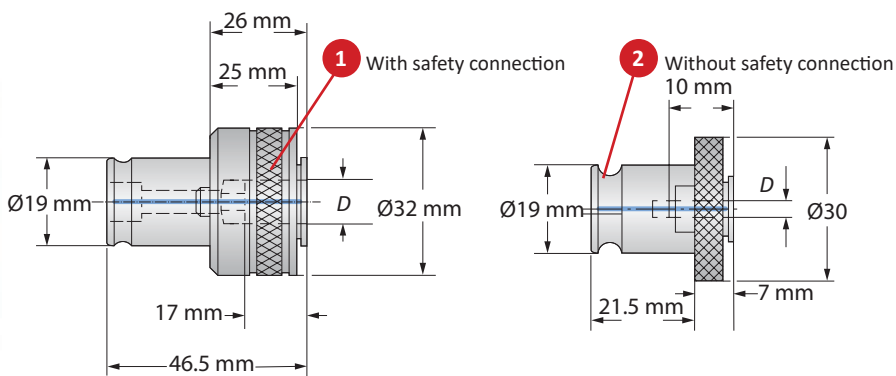

Quick Change Adapters

Shank Dimensions		Quick Change Adapter								Part No.	
Nominal Size	D x Square Shank	DIN 352	DIN 353	DIN 371	DIN 374	DIN 376	DIN 2182	DIN 2183	Torque Setting	1	2
1	2.10 x 2.80	M 2	-	M 2.8	M 4	M 4	3/32"	5/32"	2 - 3	K17847	K23259
1	2.70 x 3.50	M 3	-	M 3.5	M 5	M 5	1/8"	-	4 - 6	233001	K18455
1	3.00 x 4.00	M 3.5	-	M 3.5	-	-	-	-	1.5 - 2	233002	K22439
1	3.40 x 4.50	M 4	-	M 4	M 6	M 6	5/32"	1/4"	6 - 9	233003	K16414
1	4.90 x 6.00	M 8	-	-	M 8	M 8	-	-	16 - 21	233004	K16415
1	5.50 x 7.00	M 10	-	-	M 10	M 10	1/4"	3/8"	27 - 32	233005	K16418
1	6.20 x 8.00	-	G 1/8"	M 8	-	-	5/16"	7/16"	16 - 21	233006	K16416
1	7.00 x 9.00	M 12	-	-	M 12	M 12	3/8"	1/2"	37 - 44	233007	K18454
1	8.00 x 10.00	-	-	M 10	-	-	-	-	27 - 32	233008	K16417
1	9.00 x 11.00	M 14	G 1/4"	-	M 14	M 14	-	9/16"	50 - 53	233009	K22440

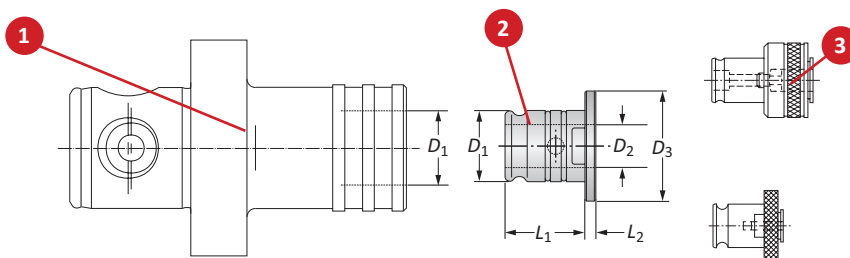

Reducers for Quick Change Adapters

1 Tapping Chuck		2 Quick Change Adapter		3. Reducer					Weight	Part No.
Nominal Size	D ₁	Nominal Size	D ₁	D ₁	D ₂	D ₃	L ₁	L ₂		
1	19.00	0	13.00	19.00	13.00	30.00	21.50	4.00	0.12 (kg)	161038
2	31.00	1	19.00	31.00	19.00	48.00	35.00	5.00	0.48 (kg)	162094

B10-M: 12-13

B10: VI-VII

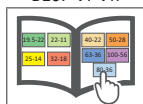
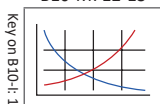

Ⓜ = Metric (mm)

Quick Change Adapters

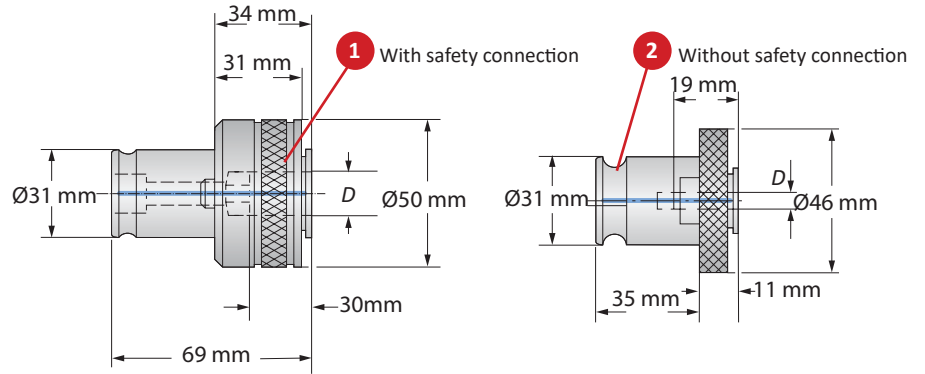

Quick Change Adapters

Shank Dimensions		Quick Change Adapter								Part No.		
Nominal Size	D x Square Shank	DIN 352	DIN 353	DIN 371	DIN 374	DIN 376	DIN 2182	DIN 2183	Torque Setting	1	2	
m	2	5.50 x 7.00	M 10	G 1/8"	-	M 10	M 10	1/4"	3/8"	24 - 32	233020	K15282
	2	6.20 x 8.00	-	-	M 8	-	-	5/16"	7/16"	16 - 21	233021	K15283
	2	7.00 x 9.00	M 12	-	-	M 12	M 12	3/8"	1/2"	37 - 44	233022	K15284
	2	8.00 x 10.00	-	-	M 10	-	-	-	-	27 - 32	233023	K18456
	2	9.00 x 11.00	M 14	G 1/4"	-	M 14	M 14	-	9/16"	50 - 53	233024	K16419
	2	9.00 x 12.00	M 16	G 3/8"	-	M 16	M 16	-	5/8"	55 - 58	233025	K15285
	2	11.00 x 14.00	M 18	-	-	M 18	M 18	-	1 1/16"	85 - 90	233026	K16420
	2	12.00 x 16.00	M 20	G 1/2"	-	M 20	M 20	-	1 3/16"	110 - 115	233027	K15286
	2	14.50 x 18.00	M 24	-	-	M 24	M 24	-	1 5/16"	110 - 115	233028	K18457

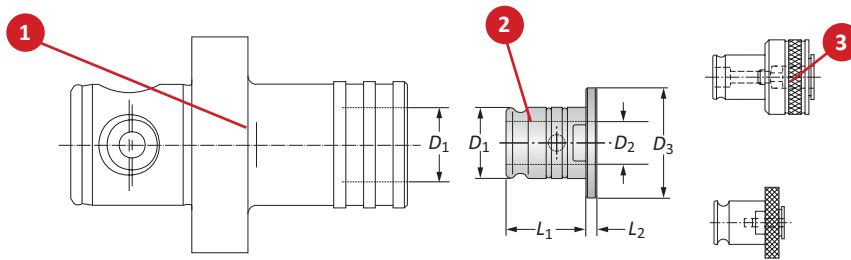

Reducers for Quick Change Adapters

1 Tapping Chuck		2 Quick Change Adapter		3 Reducer					Weight	Part No.	
Nominal Size	D ₁	Nominal Size	D ₁	D ₁	D ₂	D ₃	L ₁	L ₂			
m	1	19.00	0	13.00	19.00	13.00	30.00	21.50	4.00	0.12 (kg)	161038
	2	31.00	1	19.00	31.00	19.00	48.00	35.00	5.00	0.48 (kg)	162094

B10-M: 12-13

B10: VI-VII

Key on B10-I: 1

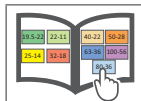
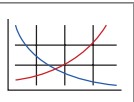

m = Metric (mm)

Quick Change Adapters

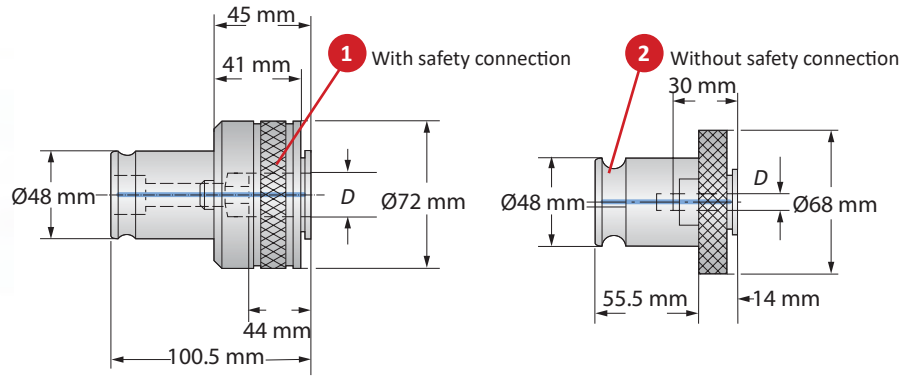

Shank Dimensions		Quick Change Adapters								Part No.	
Nominal Size	D x Square Shank	DIN 352	DIN 353	DIN 371	DIN 374	DIN 376	DIN 2182	DIN 2183	Torque Setting	1	2
3	9.00 x 11.00	M 14	G 1/4"	-	M 14	M 14	-	9/16"	50 - 53	233040	K22434
3	9.00 x 12.00	M 16	G 3/8"	-	M 16	M 16	-	5/8"	55 - 58	233041	K22435
3	11.00 x 14.00	M 18	-	-	M 18	M 18	-	11/16"	85 - 90	233042	K22436
3	12.00 x 16.00	M 20	G 1/2"	-	M 20	M 20	-	13/16"	100 - 106	233043	K22437
m	14.50 x 18.00	M 24	-	-	M 24	M 24	-	15/16"	140 - 150	233044	K16421
3	16.50 x 20.00	M 27	G 3/4"	-	M 27	M 27	-	1"	150 - 160	233045	K16422
3	18.00 x 22.00	M 30	G 7/8"	-	M 30	M 30	-	1 1/8"	240 - 250	233046	K16423
3	22.00 x 25.00	M 33	G 1"	-	M 33	M 33	-	1 1/4"	260 - 270	233047	K16424
3	22.00 x 28.00	M 36	G 1 1/8"	-	M 36	M 36	-	1 3/8"	260 - 270	233048	K22438

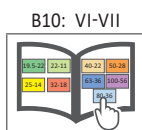
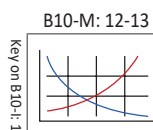

Service Keys for Collet Systems

Service Keys for ISO 10897 (DIN 6388) Collet Chuck Systems

Service Key			
Nominal Size	Size	Type	Part No.
16	40 - 43	S	068179
25	58 - 62	S	068182
32	68 - 75	S	115867

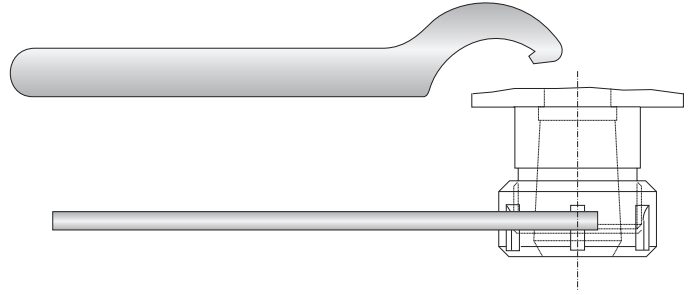

Service Keys for ISO 15488 (DIN 6499) Collet Chuck Systems

Service Key				
Nominal Size	Size	Service Key	Type	Part No.
ER 08 Mini	9.0	–	X	415373
ER 11 Mini	12.0	–	X	415374
ER 16 Mini	17.5	–	X	415375
ER 16	–	25	P	215927
ER 25	42.0	–	T	215929
ER 32	50.0	–	T	215930
ER 40	63.0	–	T	215931



Service Keys for Erickson Collet Chuck Systems

Service Key		
Service Key	Type	Part No.
13	P	315689
19	P	315691

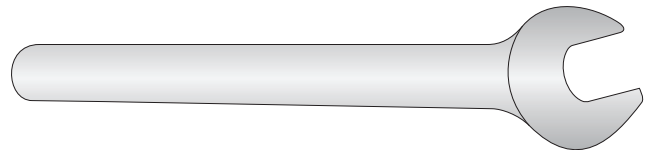

Service Keys for Milling Machine and Holding Arbors

Service Keys	
Service Key	Part No.
13	115785
16	115699
22	115660
27	115661
32	115662
40	115663
60	315637

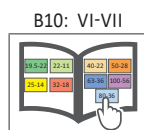
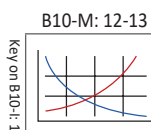
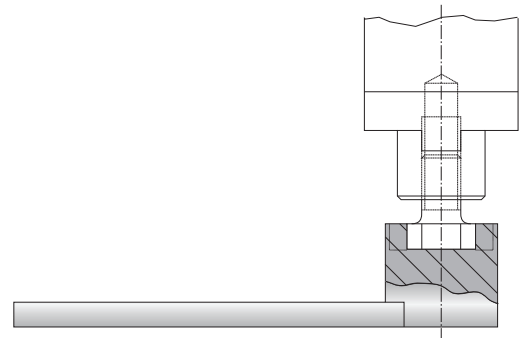

SECTION

B10-J

UPA Versatile Boring Heads

Wohlhaupter® UPA Versatile Boring Heads

UPA 3 | UPA 4 | UPA 5-S 6

▶ Diameter Range: 0.00 mm - 620.00 mm



Operation Facing and Boring

In 1936, the first model of the Wohlhaupter Universal Facing and Boring head was developed to launch the start of Wohlhaupter boring products. It became a staple to the boring industry.

Universal Facing and Boring heads are used on universal milling and boring machines, boring mills, and jig boring machines for machining stationary workpieces in individual and batch productions.

Your safety and the safety of others is very important. This catalogue contains important safety messages. Always read and follow all safety precautions.



This triangle is a safety hazard symbol. It alerts you to potential safety hazards that can cause tool failure and serious injury.

When you see this symbol in the catalogue, look for a related safety message that may be near this triangle or referred to in the nearby text.

There are safety signal words also used in the catalogue. Safety messages follow these words.

WARNING

WARNING (shown above) means that failure to follow the precautions in this message could result in tool failure and serious injury.

NOTICE means that failure to follow the precautions in this message could result in damage to the tool or machine but not result in personal injury.

NOTE and **IMPORTANT** are also used. These are important that you read and follow but are not safety-related.

Visit www.alliedmachine.com for the most up-to-date information and procedures.

Applicable Industries



Aerospace



Agriculture



Automotive



Firearms



General
Machining



Oil & Gas



Renewable
Energy

Universal Versatile Boring Heads Table of Contents

Reference Icons

The following icons will appear throughout the catalogue to help you navigate between products.



Setup / Assembly Information

Detailed instructions and information regarding the corresponding part(s)

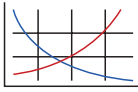

Recommended Cutting Data

Speed and feed recommendations for optimum and safe drilling

Introduction

UPA Product Overview 2 - 3

UPA 3 Boring System

UPA 3 Boring Head and Accessories 4 - 5

UPA 3 Shanks 6 - 7

UPA 4 and 5s6 Boring System

UPA 4 Boring Head and Accessories 8 - 9

UPA 5-S 6 Boring Heads and Accessories 10 - 11

UPA 4 and 5-S 6 Shanks 12

Technical Information and Chip Production Values 13

UPA Boring System Diagram 14 - 15

Series	Diameter Range
	Metric (mm)
UPA 3	0.00 - 260.00
UPA 4	0.00 - 400.00
UPA 5-S 6	0.00 - 620.00

UPA Product Overview



UPA Boring Head FACING AND BORING

Universal Facing and Boring Heads

The versatile Wohlhaupter UPA boring heads can be used for facing, boring, and taper turning. They can also be used for right- or left-handed turning.

Precise and versatile boring heads.

- Diameter range: 0.00 mm - 620.00 mm
- Slide adjustment up to 112.00 mm
- Can be used in a variety of operations

UNIVERSAL FACING AND BORING Applications

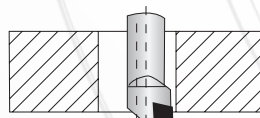
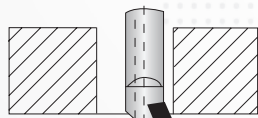
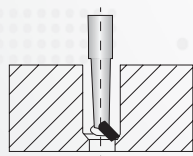

Boring with different tools

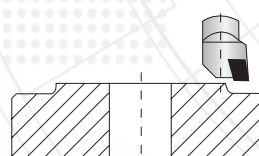

From inside outward

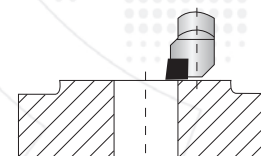

From outside inward

Facing

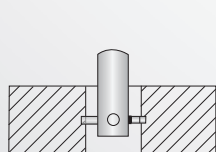

Recessing

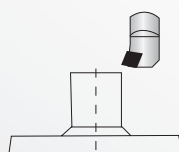

Outside Turning

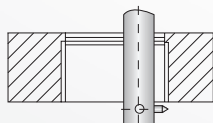

Thread Cutting

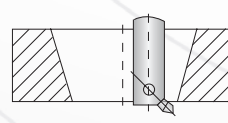

Taper Turning

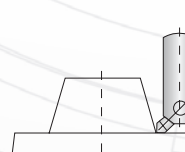

UNIVERSAL

FACING & BORING Application Examples

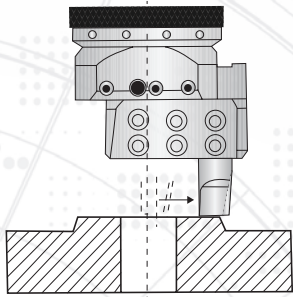

Facing with boring bar directly in slide

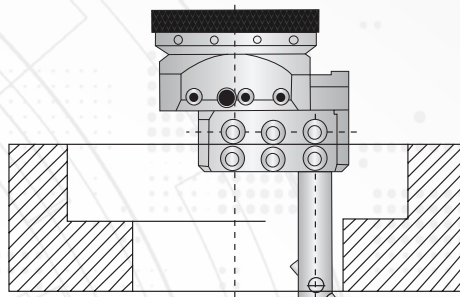

Boring with long boring bar

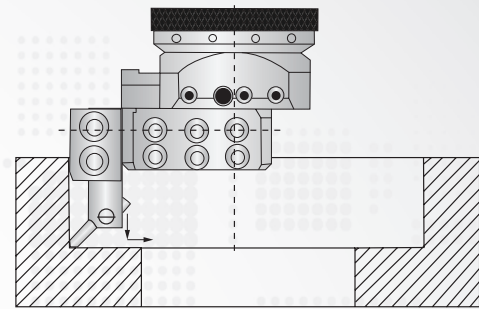

Boring and facing with short boring bar holder and a boring bar

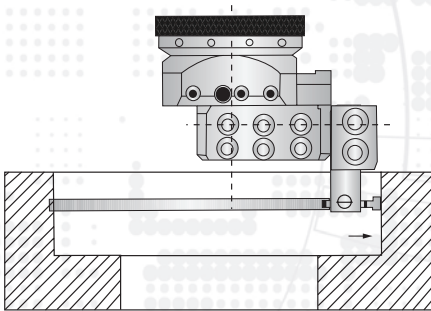

Recessing with short boring bar holder and a boring bar

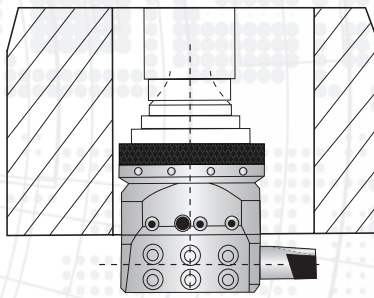

Deep hole boring with boring bar directly in slide

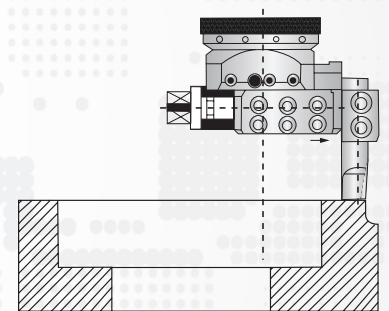

Large diameter facing with a long boring bar holder

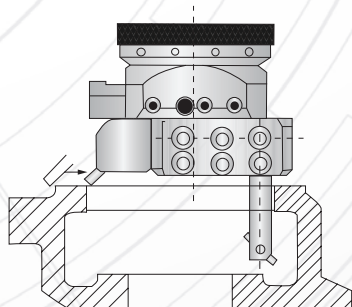

Facing in two areas with one boring bar and a boring bar holder

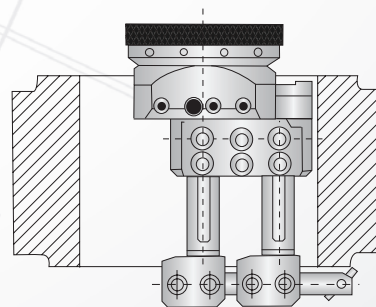

Facing the reverse side by using boring bar holders contained in attachment

UPA 3 Boring Head and Accessories

Diameter Range: 0.00 mm - 260.00 mm

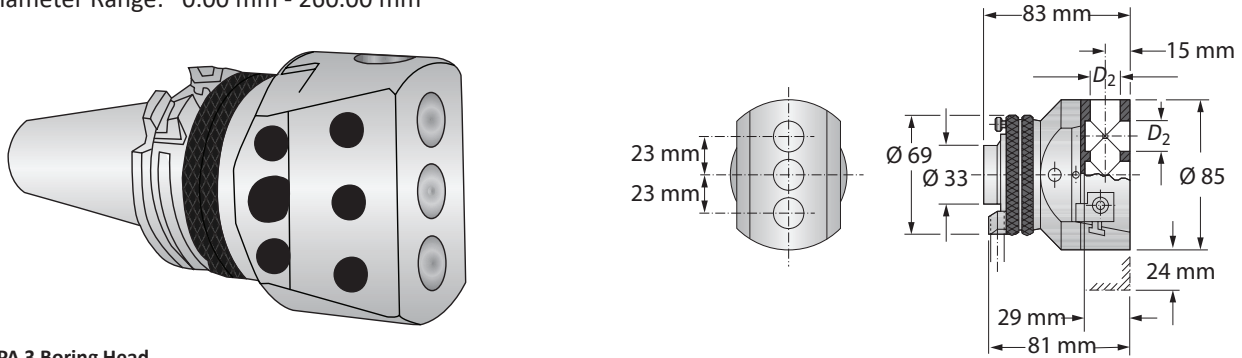

UPA 3 Boring Head

Boring Head			
Boring Range	D_2	Weight	Part No.
0.00 - 260.00	18.00	2.10 (kg)	005020

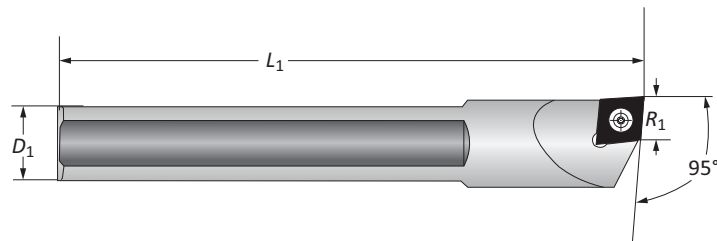

UPA 3 Boring Bars

Boring Bar				Cutting Direction	Insert Form	Part No.
D_1	L_1	R_1	Weight			
18.00	80.00	13.50	0.10 (kg)	R	103	081087
18.00	80.00	13.50	0.10 (kg)	L	103	218088

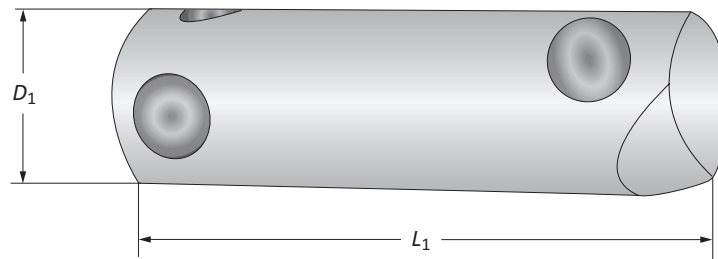

UPA 3 Boring Bars

Boring Bar		Boring Depth	Designation	Part No.
D_1	L_1			
18.00	60.00	30.00	B 306	073003
18.00	90.00	60.00	B 309	073004
18.00	120.00	90.00	B 312	073005

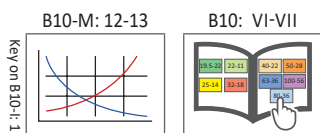

m = Metric (mm)

UPA 3 Accessories

Reducing Sleeves | Boring Bar Holders

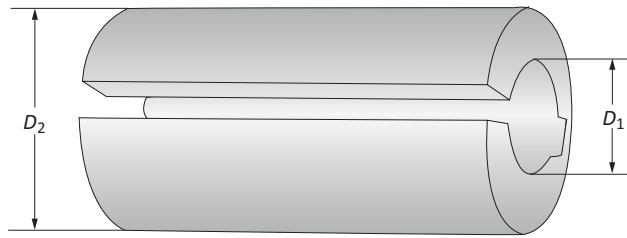

UPA 3 Reducing Sleeves

Reducing Sleeve		Weight	Part No.
D_2	D_1		
18.00	8.00	0.10 (kg)	071103
18.00	10.00	0.10 (kg)	071104
18.00	12.00	0.10 (kg)	071105
18.00	14.00	0.10 (kg)	071106

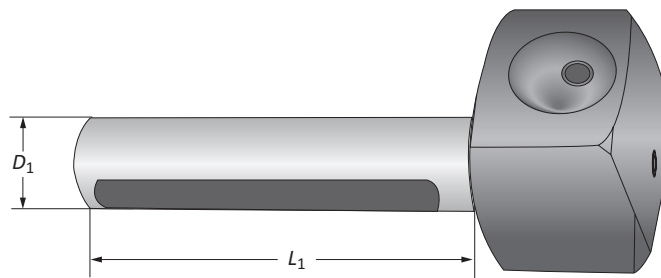

UPA 3 Boring Bar Holders

Boring Bar Holder		Working Diameter Range	Designation	Part No.
D_1	L_1			
18.00	82.00	85.00 - 190.00	BH 308	075001
18.00	120.00	160.00 - 260.00	BH 312	075002

UPA 3 Square Turning Bit

Square Turning Bit		Weight	Part No.
S	L_1		
6.00	40.00	11 (g)	089001

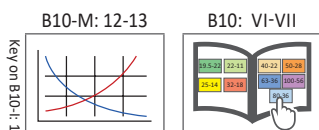
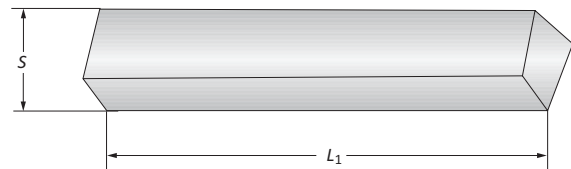

m = Metric (mm)

UPA 3 Master Shanks

CAT 40/50 | Morse Taper

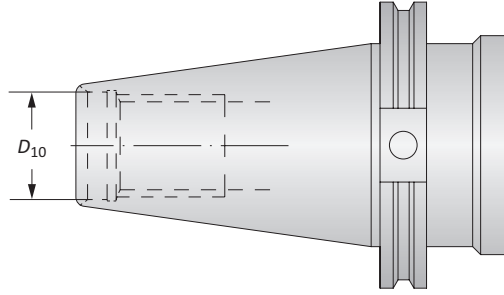

CAT 40/50 Shanks

		Shank			
		Style	D_{10}	Weight	Part No.
m		CAT 40	M16 x 2	1.06 (kg)	130001T016960
		CAT 50	M24 x 3	3.20 (kg)	130001T016962

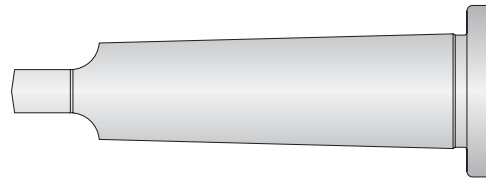

Morse Taper Shanks

		Shank		
		Style	Weight	Part No.
m		MT 3	0.30 (kg)	130001T004509
		MT 4	0.55 (kg)	130001T003590
		MT 5	1.35 (kg)	130001T003920

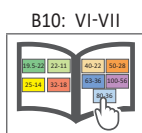
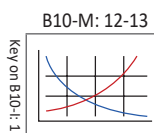

m = Metric (mm)

UPA 3 Master Shanks

R-8 | NMTB 40/50

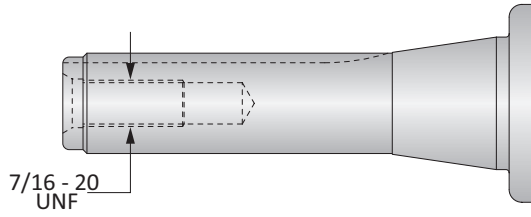

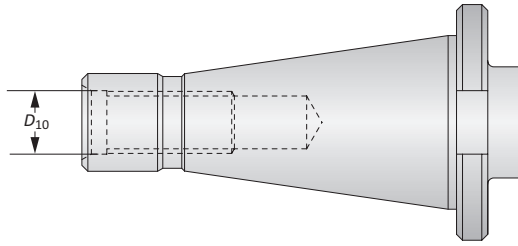

R-8 Shanks

Shank		Part No.
Weight		
 0.48 (kg)	130001T007166	



NMTB 40/50 Shanks

Shank		Weight	Part No.
Style	D_{10}		
 NMTB40	$\frac{3}{8}$ - 11	0.90 (kg)	130001T004498
 NMTB50	1 - 8	2.63 (kg)	130001T004480

Differential Screw

Thread	Weight	Part No.
 M16 x 2	0.03 (kg)	KW9208

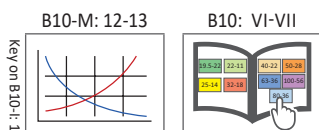

 = Metric (mm)

UPA 4 Boring Heads and Accessories

Diameter Range: 0.000" - 15.748" (0.00 mm - 400.00 mm)

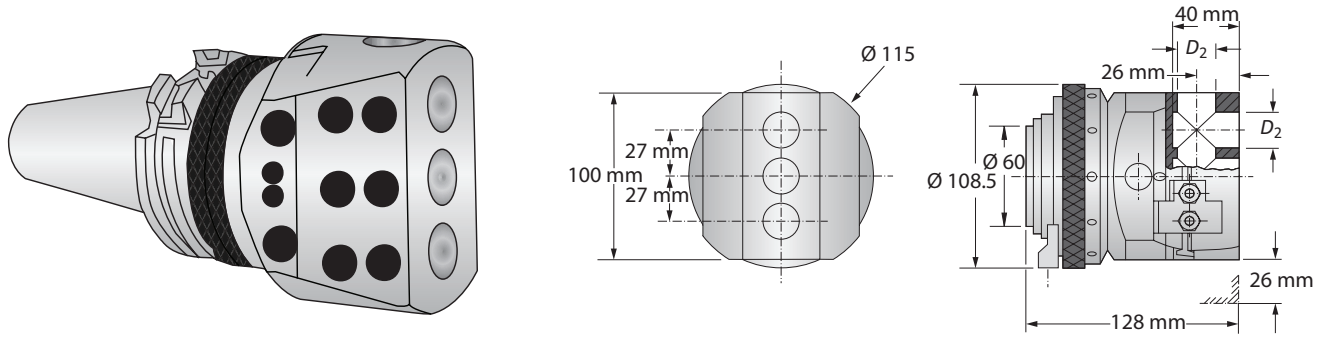

UPA 4 Boring Heads

		Boring Head		
Boring Range	D_2	Weight	Part No.	
0.00 - 400.00	22.00	6.50 (kg)	007020	

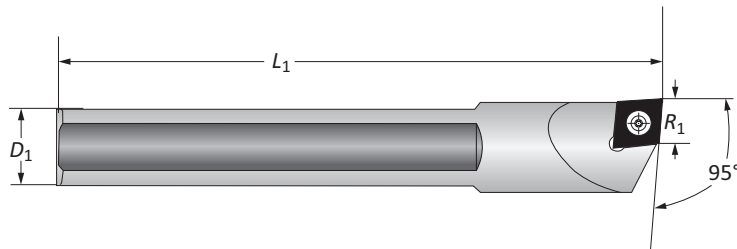

UPA 4 Boring Bars

		Boring Bar					
D_1	L_1	R_1	Weight	Cutting Direction	Insert Form	Part No.	
22.00	100.00	13.50	0.10 (kg)	R	103	081092	
22.00	100.00	13.50	0.10 (kg)	L	103	218089	

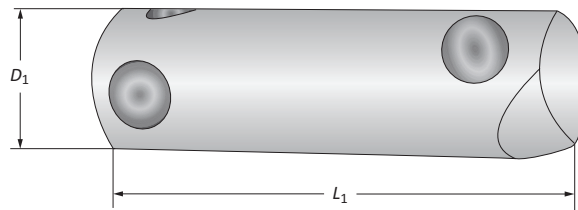

UPA 4 Boring Bars

		Boring Bar			
D_1	L_1	Boring Depth	Designation	Part No.	
22.00	85.00	45.00	B 408	073006	
22.00	125.00	85.00	B 412	073007	
22.00	165.00	125.00	B 416	073008	

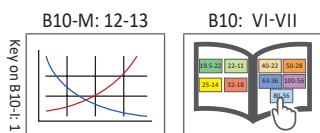

UPA 4 Accessories

Reducing Sleeves | Boring Bar Holders

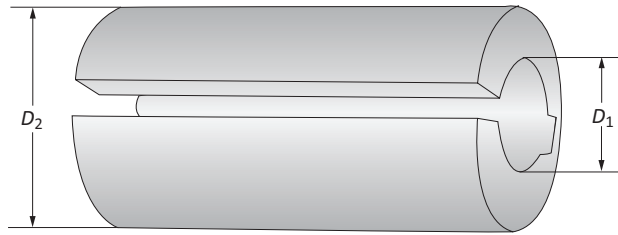

UPA 4 Reducing Sleeves

Reducing Sleeve				
	D_2	D_1	Weight	Part No.
m	22.00	8.00	0.10 (kg)	071107
	22.00	10.00	0.10 (kg)	071108
	22.00	12.00	0.10 (kg)	071109
	22.00	14.00	0.08 (kg)	071110
	22.00	18.00	0.08 (kg)	071111

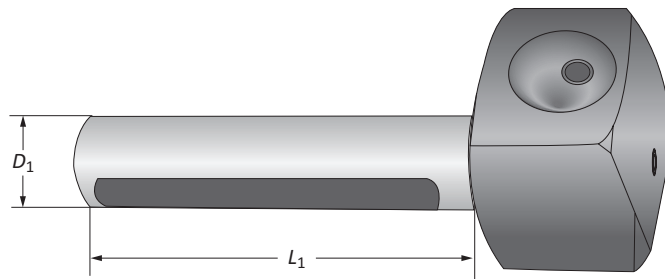

UPA 4 Boring Bar Holders

Boring Bar Holder					
	D_1	L_1	Designation	Working Diameter Range	Part No.
m	22.00	98.00	BH 410	115.00 - 240.00	075003
	22.00	180.00	BH 418	220.00 - 400.00	075004

UPA 4 Square Turning Bit

Square Turning Bit				
	S	L_1	Weight	Part No.
m	6.00	40.00	11 (g)	089001

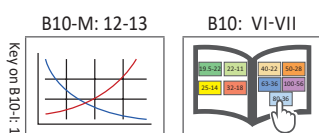
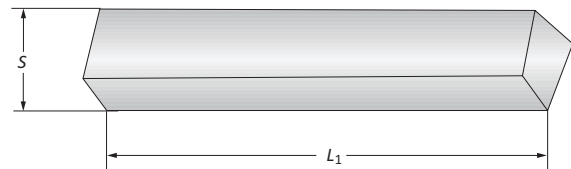

m = Metric (mm)

UPA 5-S 6 Boring Heads and Accessories

Diameter Range: 0.00 mm - 620.00 mm

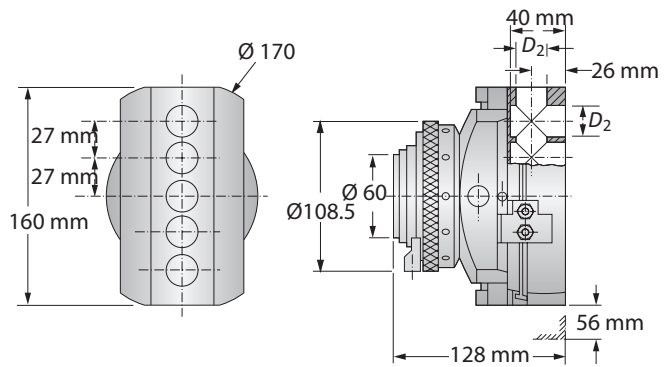
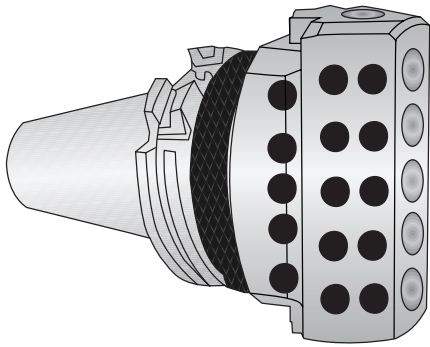

UPA 5-S 6 Boring Heads

		Boring Head		
	Boring Range	D_2	Weight	Part No.
m	0.00 - 620.00	22.00	7.90 (kg)	013020

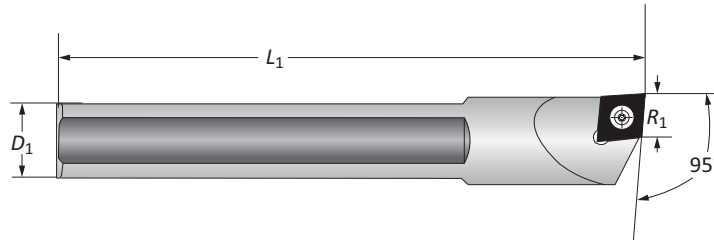

UPA 5-S 6 Boring Bars

		Boring Bar					
	D_1	L_1	R_1	Weight	Cutting Direction	Insert Form	Part No.
m	22.00	100.00	13.50	0.10 (kg)	R	103	081092
	22.00	100.00	13.50	0.10 (kg)	L	103	218089

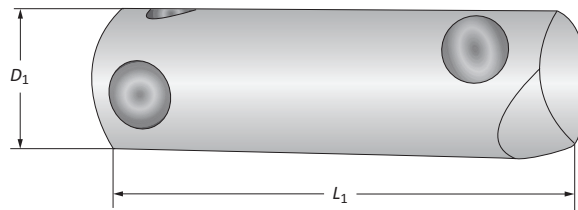

UPA 5-S 6 Boring Bars

		Boring Bar			
	D_1	L_1	Boring Depth	Designation	Part No.
m	22.00	85.00	45.00	B 408	073006
	22.00	125.00	85.00	B 412	073007
	22.00	165.00	125.00	B 416	073008

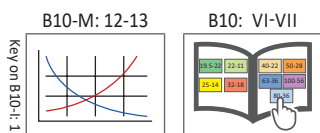

m = Metric (mm)

UPA 5-S 6 Accessories

Reducing Sleeves | Boring Bar Holders

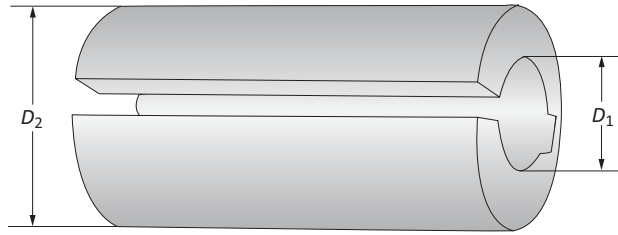

UPA 5-S 6 Reducing Sleeves

Reducing Sleeve		Weight	Part No.
D_2	D_1		
22.00	8.00	0.10 (kg)	071107
22.00	10.00	0.10 (kg)	071108
22.00	12.00	0.10 (kg)	071109
22.00	14.00	0.08 (kg)	071110
22.00	18.00	0.08 (kg)	071111

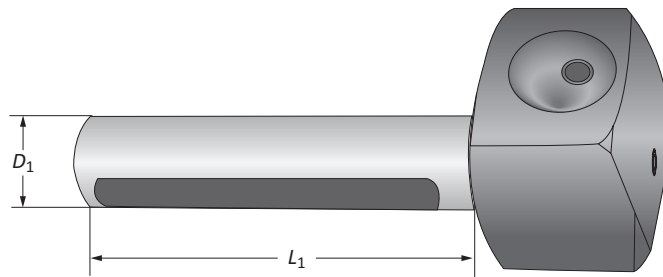

UPA 5-S 6 Boring Bar Holders

Boring Bar Holder		Designation	Working Diameter Range	Part No.
D_1	L_1			
22.00	228.00	BH 513	120.00 - 400.00	075003
22.00	230.00	BH 523	270.00 - 620.00	075004

UPA 5-S 6 Square Turning Bit

Square Turning Bit			
S	L_1	Weight	Part No.
6.00	40.00	11 (g)	089001

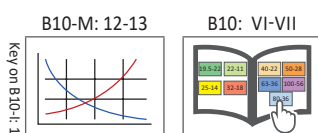
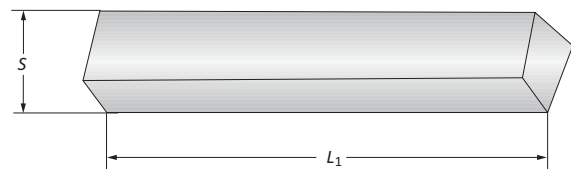

m = Metric (mm)

UPA 4 and 5-S 6 Master Shanks

CAT 40/50 | Morse Taper | NMTB 40/50

CAT 40/50 Shanks

Shank				
Style	D_{10}	Weight	Part No.	
m CAT 40	M16 x 2	1.45 (kg)	130005T016960	
CAT 50	M24 x 3	3.20 (kg)	130005T016962	

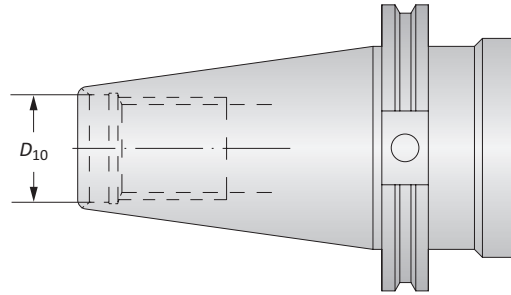

Morse Taper Shanks

Shank			
Style	Weight	Part No.	
m MT 4	0.86 (kg)	130005T003590	
MT 5	1.65 (kg)	130005T003920	

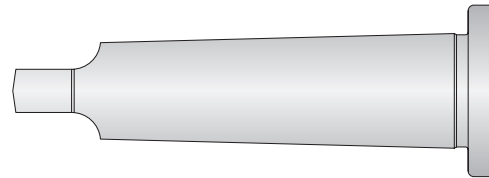

NMTB 40/50 Shanks

Shank				
Style	D_{10}	Weight	Part No.	
m NMTB40	$\frac{5}{8}$ - 11	1.30 (kg)	130005T004498	
NMTB50	1 - 8	2.90 (kg)	130005T004480	

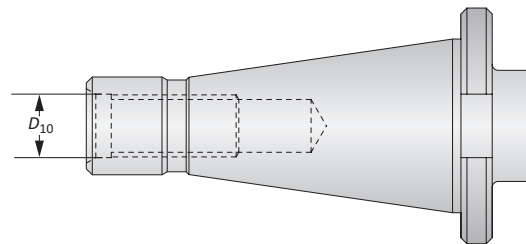

Differential Screw

Thread	Weight	Part No.
m M20 x 2.5	0.07 (kg)	KW9209

B10-M: 12-13

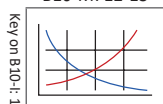

B10: VI-VII

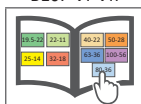

Technical Information | Chip Production Values

Technical Data

Type	UPA 3	UPA 4	UPA 5-S 6
Working accuracy	±0.005	±0.005	±0.005
Diameter range	25.00	35.00	45.00
MT shank	3.00	4.00	5.00
ISO shank	30.00	40.00	40.00
Facing and boring range	0.00 - 260.00	0.00 - 400.00	0.00 - 620.00
Adjustment of slide (max)	48.00	52.00	112.00
Self-activated feed of slide per revolution	0.05	0.02, 0.04, 0.06, 0.08, 0.10, 0.12, 0.14, 0.16, 0.18, 0.20, 0.22, 0.24	0.02, 0.04, 0.06, 0.08, 0.10, 0.12, 0.14, 0.16, 0.18, 0.20, 0.22, 0.24
Fine adjustment of one division	0.01	0.01	0.01
Fine adjustment of one revolution	1.00	0.40	0.40
Rapid return per revolution	1.00	-	-
Rapid return setting per revolution	-	6.00	6.00
Largest diameter of slide	85.00	115.00	170.00
Height of boring head without shank	81.00	128.00	128.00
Tool locations in slide	18.00	22.00	22.00
Max permissible revolutions	1000	600	600
End cut off accuracy	±0.05	±0.05	±0.05

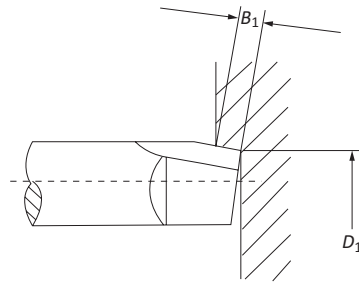

Chip Production Values

Chip Cutting Guide	Type	UPA 3	UPA 4	UPA 5-S 6
Max load	kW	2.50	7.00	9.50
With slide feed	mm/rev.	0.050	0.08, 0.12, 0.24	0.08, 0.12, 0.24
For smaller working \varnothing	D_1	60.00	150.00	200.00
Maximum width of chip	B_1	4.00	7.00, 6.00, 4.00	8.00, 7.00, 5.00
Maximum working \varnothing	D_1	260.00	400.00	500.00 / 620.00
Max width of clip without reinforcement rings	B_1	2.00	2.20, 2.00, 1.50	2.50, 2.00, 1.50
Max width of clip with reinforcement rings*	B_1	-	4.50, 4.00, 3.00	5.00, 4.00, 3.00

*By using the reinforcement rings contained in the normal attachment, chip cutting capacity is increased by 100%

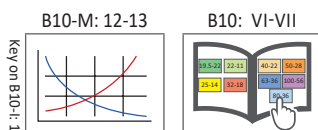

m = Metric (mm)

UPA 3 Boring Head Diagram

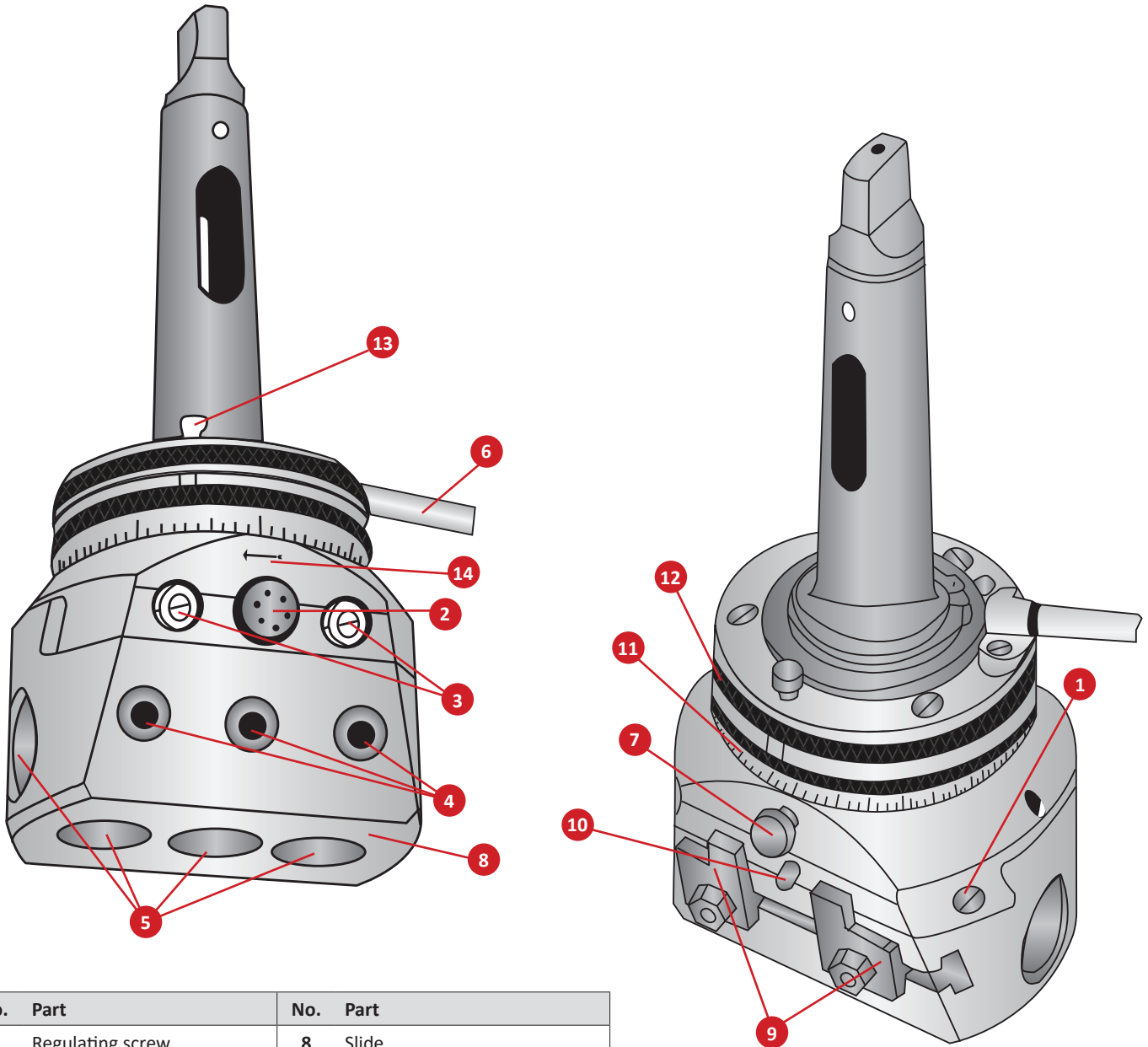

No.	Part	No.	Part
1	Regulating screw	8	Slide
2	Locking screw	9	Stop
3	Setting screws	10	Fixed pin
4	Fastening screw	11	Scale ring
5	Tool post holes	12	Holding ring
6	Holding rod	13	Button for return movement
7	Feed button	14	Arrow

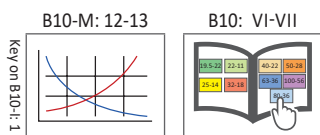

A
B
C
D
E
F
G
H
I
J
K
L
M
INDEX

UPA 4 / 5-S 6 Boring Heads Diagram

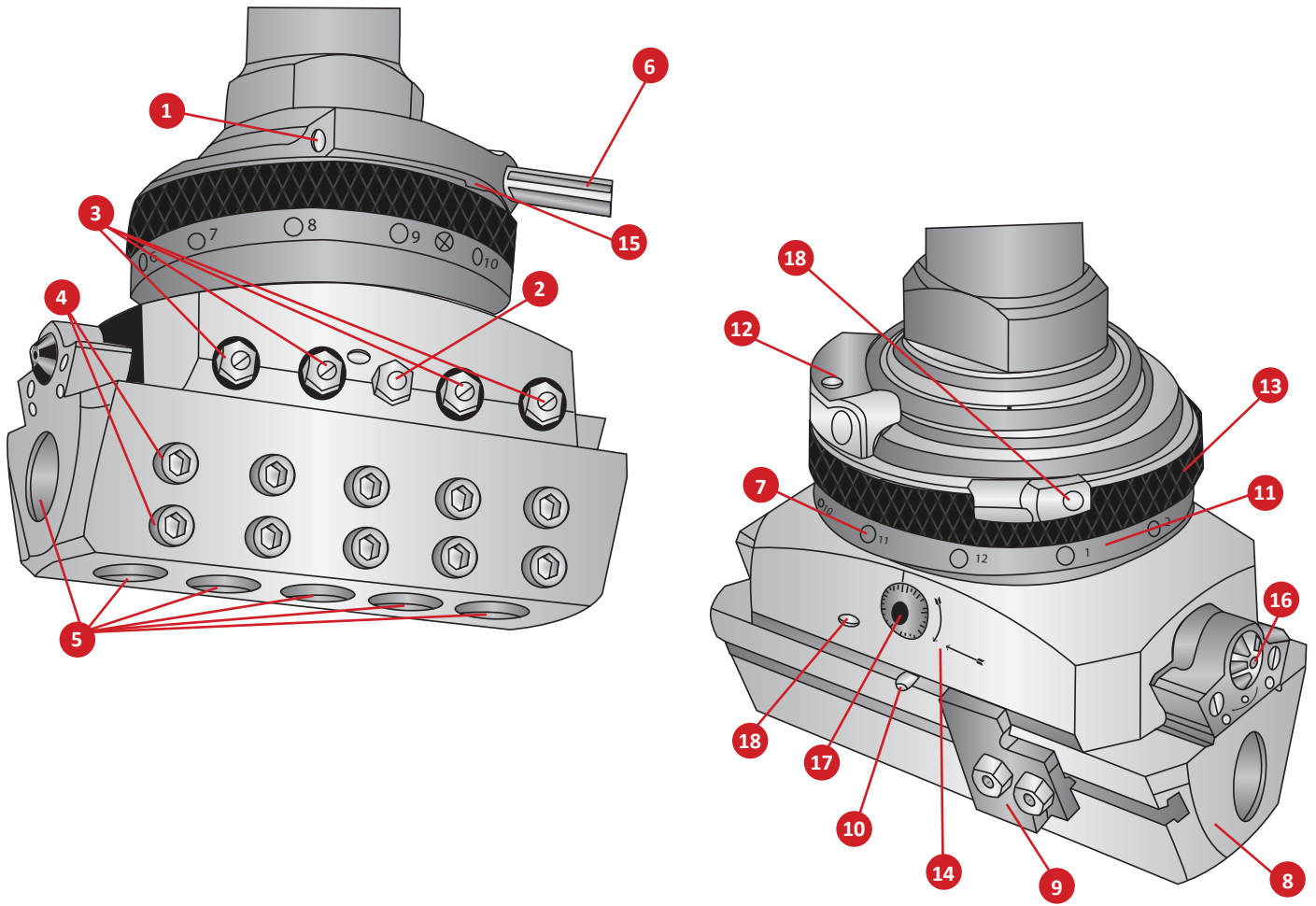

No.	Part	No.	Part
1	Regulating screw	10	Fixed pin
2	Locking screw	11	Scale ring
3	Setting screws	12	Retaining ring
4	Fastening screws	13	Feed ring
5	Tool post holes	14	Arrow
6	Holding rod	15	Recess
7	Feed buttons	16	Quick setting dial
8	Slide with rotation bores	17	Fine setting dial
9	Stop	18	Release ring

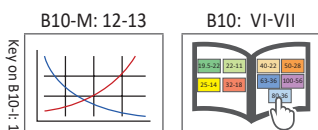

 = Metric (mm)

SECTION

B10-K

Special Boring Solutions

Wohlhaupter® Special Boring Solutions



Special Design Tooling

When it comes to special solutions for customers, Wohlhaupter has unique capabilities to effectively design and develop special boring tools. Our special boring tools are designed for specific machines, processes, and materials to help you save time and money.

If you have a particularly unique or difficult application, contact our Application Engineering team.

email: engineering.eu@alliedmachine.com

Your safety and the safety of others is very important. This catalogue contains important safety messages. Always read and follow all safety precautions.



This triangle is a safety hazard symbol. It alerts you to potential safety hazards that can cause tool failure and serious injury.

When you see this symbol in the catalogue, look for a related safety message that may be near this triangle or referred to in the nearby text.

There are safety signal words also used in the catalogue. Safety messages follow these words.

WARNING

WARNING (shown above) means that failure to follow the precautions in this message could result in tool failure and serious injury.

NOTICE means that failure to follow the precautions in this message could result in damage to the tool or machine but not result in personal injury.

NOTE and **IMPORTANT** are also used. These are important that you read and follow but are not safety-related.

Visit www.alliedmachine.com for the most up-to-date information and procedures.

Applicable Industries



Aerospace



Agriculture



Automotive



Firearms



General
Machining



Oil & Gas



Renewable
Energy

Wohlhaupter® Special Boring Solutions Table of Contents

Special Tooling Solutions

ES-Bore Fine Boring Lay Down Cartridge	2
EK Groover Lay Down Cartridge	3
Anti-Vibration Multistep Boring Tool	4
OD Turning Tool Padded Line Boring Tool	5
3E ^{TECH+} Special Tools	6
DigiBore Special Boring Tools	7
Combi-Line Special Boring Tool	8

Online Tools	9
-------------------------------	---

ES-Bore Fine Boring Lay Down Cartridge

A
B
C
D
E
F
G
H
I
J
K
L
M
INDEX

DIGITAL ES-BORE WITH ADAPTER PLATE



NOTE: ES-Bore digital fine boring cartridges must be used with the new 3E^{TECH+} and adapter plate. The ES-Bore cannot be used with 3E^{TECH}.

NOTE: 3E^{TECH+} adjustment accuracy of 0.001 mm on diameter



ANALOG ES-BORE

LAY DOWN CARTRIDGES

ES-BORE

- ▶ Mounts to custom designed boring tools
- ▶ Available with digital 3E^{TECH+} or analog adjustment
- ▶ Accurate adjustments with easy-to-use settings
- ▶ Versatility in many different application types over 1.102" (28.00 mm)



GROOVING TOOLS

EK GROOVER

- ▶ Create complex grooves faster and deeper than ever before
- ▶ Eliminate chatter in hard-to-reach internal forms
- ▶ The electronically-controlled insert release can be adapted to most machine tools
- ▶ Single or double grooving in one operation

ROUGH BORING TOOLS

LAY DOWN CARTRIDGE

- ▶ Increase the productivity of your roughing tool while protecting your investment
- ▶ If the tool is ever damaged, simply replace a cartridge and resume making chips



SPECIAL BORING TOOLS
ANTI-VIBRATION

- ▶ Vibration dampening rings
- ▶ Optimized tool weight
- ▶ Used to reduce harmonic vibration in deeper boring applications

SPECIAL BORING TOOLS
MULTISTEP BORING TOOL

- ▶ Fine adjustment tool for reverse machining
- ▶ Combined with multidiameter fine adjustable cartridges for finish machining



SPECIAL BORING TOOLS

OD TURNING TOOLS

- ▶ Multistep OD turning
- ▶ Drastically reduce cycle time
- ▶ Improve surface finish and feature concentricity

SPECIAL BORING TOOLS

PADDED TOOLING

- ▶ Aids in stable part processing
- ▶ Expands length to diameter capabilities
- ▶ Improves surface finish
- ▶ Pads are replaceable to extend tool life



NOTE: 3E^{TECH+} adjustment accuracy of 0.001 mm on diameter



NOTE: 3E^{TECH+} adjustment accuracy of 0.001 mm on diameter

3E^{TECH+} BORING TOOL

MULTISTEP BORING TOOL

- ▶ Easy diameter adjustments with 3E^{TECH+}
- ▶ One digital readout module to use on all steps

3E^{TECH+} BORING TOOL

LINE BORING TOOL

- ▶ One digital readout module used on all steps
- ▶ Easy diameter adjustment at the machine spindle

DigiBore Special Boring Tools



NOTE: Metric item pictured
NOTE: Digital adjustment accuracy of 0.002 mm on diameter



NOTE: Metric item pictured
NOTE: Digital adjustment accuracy of 0.002 mm on diameter

FINISH BORING TOOLS

DIGIBORE WITH 249 (248)

- ▶ Standard DigiBore head, standard 249 (248) head, and special slide for precise two-step bore
- ▶ MVS connection

FINISH BORING TOOLS

DIGIBORE SPECIAL

- ▶ Standard DigiBore boring head with OD turn and OD chamfer insert holder
- ▶ MVS connection

Combi-Line Special Boring Tool

A

B

C

D

E

F

G

H

I

J

K

L

M

INDEX



ROUGH, FINISH, and CHAMFER BORING TOOLS

COMBI-LINE

- ▶ Standard Combi-Line tooling with added chamfer cartridge
- ▶ MVS connection

Online Tools

ToolMD® | Wohlhaupter® Boring Insert Selector

ToolMD®

www.toolmd.com

Design Your Own Solutions

ToolMD is a configurator for Wohlhaupter modular tooling systems that allows customers to virtually build their own solution. This online-based simulator puts the entire Wohlhaupter product line at your fingertips. It provides a digital bank of every individual part that Wohlhaupter manufactures in either inch or metric.

Once you select a component, you will be guided by a series of user-friendly prompts to select the next components until you have built your tooling system. Throughout the process, you can monitor the size of your custom tool and ensure what you're building matches your real-life specifications. Once a complete system is virtually assembled, the program will render the tool in either a 2D or 3D drawing to view on your device.

Designing your tools with ToolMD saves you time and allows you to instantly obtain the right tool for the job.



 Design anytime from anywhere.
Available online 24/7.

WOHLHAUPTER® | Boring Insert Selector

www.alliedmachine.com/bis



- Generate the correct boring insert for your application in just six easy steps



- Search for your new insert item number by entering your old item number

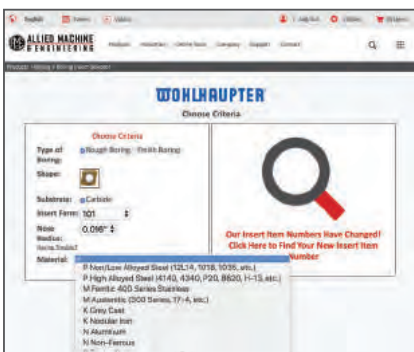

- Choose type, shape, substrate, insert form, nose radius, and workpiece material
- Order easily by adding the item to your cart

A
B
C
D
E
F
G
H
I
J
K
L
M
INDEX

SECTION

B10-L

Lay Down Cartridges

Wohlhaupter® Lay Down Cartridges

Holders for Pre-Machining | Holders for Compact Boring Bars | Short Clamp Holders | Fine Boring Holders

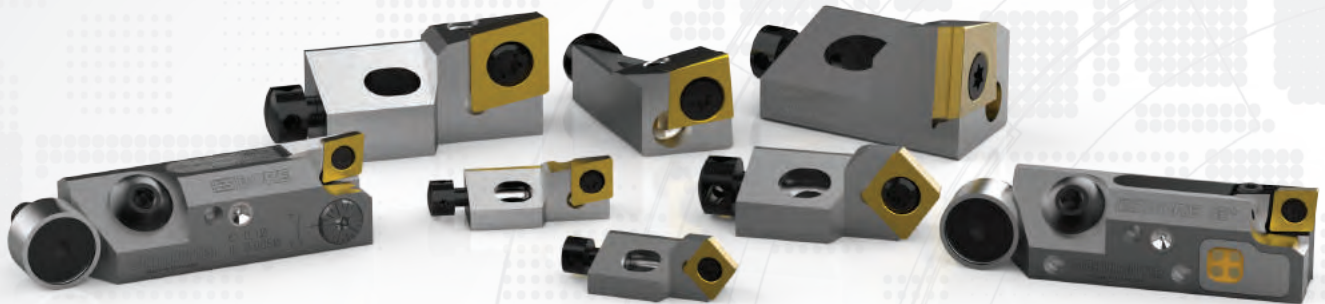

Robust. Powerful. Versatile. Engineered Solutions.

From pre-machining holes with heavy stock removal to finish machining with tight tolerances and excellent surface finish, Wohlhaupter's extensive range of lay down cartridges can help you achieve specific boring solutions. Wohlhaupter's lay down cartridges bring innovative concepts designed to improve productivity, reduce scrap, and reduce the cost per part.

Your safety and the safety of others is very important. This catalogue contains important safety messages. Always read and follow all safety precautions.



This triangle is a safety hazard symbol. It alerts you to potential safety hazards that can cause tool failure and serious injury.

When you see this symbol in the catalogue, look for a related safety message that may be near this triangle or referred to in the nearby text.

There are safety signal words also used in the catalogue. Safety messages follow these words.

WARNING

WARNING (shown above) means that failure to follow the precautions in this message could result in tool failure and serious injury.

NOTICE means that failure to follow the precautions in this message could result in damage to the tool or machine but not result in personal injury.

NOTE and **IMPORTANT** are also used. These are important that you read and follow but are not safety-related.

Visit www.alliedmachine.com for the most up-to-date information and procedures.

Applicable Industries



Aerospace



Agriculture



Automotive



Firearms



General
Machining



Oil & Gas



Renewable
Energy

Lay Down Cartridges Table of Contents

Reference Icons

The following icons will appear throughout the catalogue to help you navigate between products.

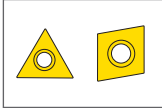

Inserts

For use with insert holder boring heads and boring bars using indexable inserts

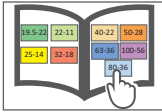

MVS Connection Color Guide

Detailed instructions and information regarding the MVS connection(s)

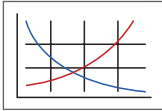

Recommended Cutting Data

Speed and feed recommendations for optimum and safe boring

ES-Bore Lay Down Cartridges

Digital 3E ^{TECH+} Insert Forms 101 and 20.	2
Analogue Insert Forms 101 and 20.	3
Mounting Dimensions.	4
Accessories.	5

Compact Lay Down Cartridges

Insert Forms 101, 103, 104 and 105.	6
Insert Form 112.	7
Insert Forms 04 and 05.	8
Mounting Dimensions.	9
Accessories.	10

ES-Bore Digital 3E^{TECH+} Fine Boring Cartridges | Insert Forms 101 and 20

Diameter Range: ≥1.102" (28.00 mm)

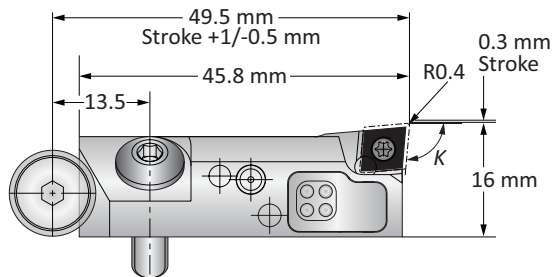

Holder Type	K	ISO	Minimum Boring Diameter	Cutting Direction	Insert Form	Weight	Part No.
	90°	CC.. 0602..	28.00	Right	101	0.06 (kg)	345032
	90°	CC.. 0602..	28.00	Left	101	0.06 (kg)	345033
	90°	TOGX 0802..	28.00	Right	20	0.06 (kg)	345042
	90°	TOGX 0802..	28.00	Left	20	0.06 (kg)	345043
	95°	CC.. 0602..	28.00	Right	101	0.06 (kg)	345030
	95°	CC.. 0602..	28.00	Left	101	0.06 (kg)	345031
	95°	TOGX 0802..	28.00	Right	20	0.06 (kg)	345040
	95°	TOGX 0802..	28.00	Left	20	0.06 (kg)	345041

NOTE: ES-Bore digital fine boring cartridges must be used with the new 3E^{TECH+} and adapter plate. The ES-Bore cannot be used with 3E^{TECH}.
NOTE: 3E^{TECH+} module, adapter, and charging unit sold separately.

3E^{TECH+} Digital Readout Module

Part No.	Charging Unit*
536015	536016

NOTE: WEEE-Reg.-Nr. DE 15820388
 *Charging unit sold separately



NOTE: 3E^{TECH+} adjustment accuracy of 0.001 mm on diameter

Adapter Plate for 3E^{TECH+}

Cutting Direction	Part No.
Right	536017
Left	536018

NOTE: Adapter sold separately.



B10-M: 12-13

B10-H



B10: VI-VII

m = Metric (mm)
 Inserts sold separately

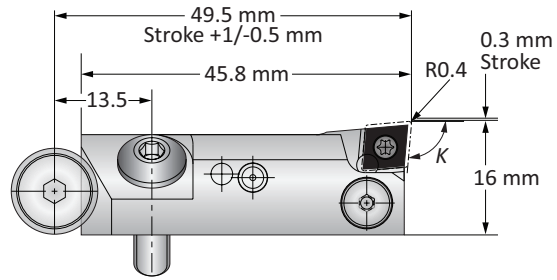

ES-Bore Analogue Fine Boring Cartridges | Insert Forms 101 and 20

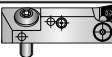
Diameter Range: $\geq 1.102''$ (28.00 mm)

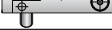

Holder Type	K	ISO	Minimum Boring Diameter	Cutting Direction	Insert Form	Weight	Part No.
	90°	CC.. 0602..	28.00	Right	101	0.06 (kg)	345036
	90°	CC.. 0602..	28.00	Left	101	0.06 (kg)	345037
	90°	TOGX 0802..	28.00	Right	20	0.06 (kg)	345046
	90°	TOGX 0802..	28.00	Left	20	0.06 (kg)	345047
	95°	CC.. 0602..	28.00	Right	101	0.06 (kg)	345034
	95°	CC.. 0602..	28.00	Left	101	0.06 (kg)	345035
	95°	TOGX 0802..	28.00	Right	20	0.06 (kg)	345044
	95°	TOGX 0802..	28.00	Left	20	0.06 (kg)	345045

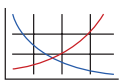
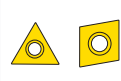
Ⓜ

B10-M: 12-13  B10-H  B10: VI-VII 

Key on B10-L: 1

Ⓜ = Metric (mm)
Inserts sold separately

ES-Bore Accessories

Screws | Service Keys | 3E^{TECH+} Accessories

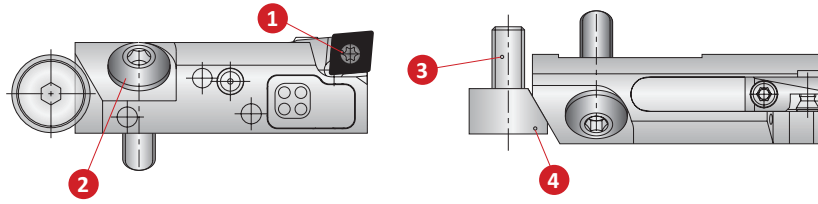

	1 Insert Screw		2 Mounting Screw	3 Height Adjusting Screw	4 Height Adjusting Wedge
	Insert Form 101	Insert Form 20			
Screw	115676 (T8)	115535 (T7)	515632 (s3)	115466 (s3)	415721
Service Key	115590	115591	051110	051110	-

3E^{TECH+} Accessories

1 Charging Unit
Part No. 536016

NOTE: Charging unit sold separately from 3E^{TECH+}



NOTE: 3E^{TECH+} adjustment accuracy of 0.001 mm on diameter

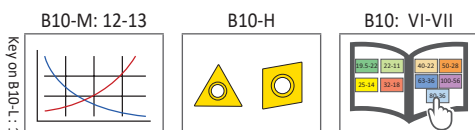

 = Metric (mm)
Inserts sold separately

Compact Lay Down Cartridges | Insert Forms 101, 103, 104 & 105

Diameter Range: ≥ 25.00 mm

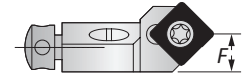
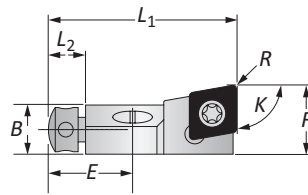
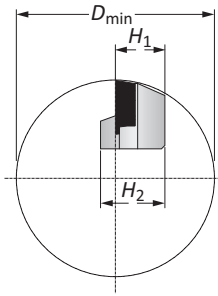
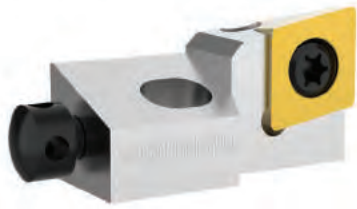



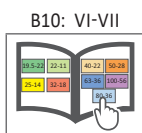
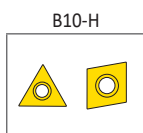
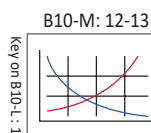



Holder Type	K	ISO	D_{min} Boring Range	Designation	Insert Holder								Insert Form	Part No.
					L_1	L_2	B	H_1	H_2	F	R Radius	E		
	90°	CC..0602..	25.00	SCFCR08CK-06	28.00	6.00	6.50	8.00	10.00	10.00	0.40	13.00	101	345001
	90°	CC..09T3..	40.00	SCFCR10CK-09	38.00	7.50	10.00	10.00	13.00	14.00	0.80	17.00	103	345002
	90°	CC..1204..	50.00	SCFCR12CK-12	45.00	8.00	14.00	12.00	16.00	20.00	0.80	20.00	104	345003
	90°	CC..1605..	55.00	SCFCR14CK-16	54.00	8.00	16.00	14.00	18.00	23.00	0.80	23.50	105	345004
	80°	CC..0602..	25.00	SCOCR08CK-06	28.00	6.00	6.50	8.00	10.00	9.00	0.40	13.00	101	345014
	80°	CC..09T3..	40.00	SCOCR10CK-09	38.00	7.50	10.00	10.00	13.00	12.50	0.80	17.00	103	345009
	75°	CC..0602..	25.00	SCR08CK-06	28.00	6.00	6.50	8.00	10.00	8.50	0.40	13.00	101	345013
	75°	CC..09T3..	40.00	SCR10CK-09	38.00	7.50	10.00	10.00	13.00	11.70	0.80	17.00	103	345008
	70°	CC..0602..	25.00	SCPCR08CK-06	28.00	6.00	6.50	8.00	10.00	8.00	0.40	13.00	101	345012
	70°	CC..09T3..	40.00	SCPCR10CK-09	38.00	7.50	10.00	10.00	13.00	11.00	0.80	17.00	103	345007
	60°	CC..0602..	25.00	SCTCR08CK-06	28.00	6.00	6.50	8.00	10.00	7.00	0.40	13.00	101	345011
	60°	CC..09T3..	40.00	SCTCR10CK-09	38.00	7.50	10.00	10.00	13.00	9.70	0.80	17.00	103	345006
	45°	CC..0602..	25.00	SCSCR08CK-06	24.00	6.00	6.50	8.00	10.00	10.00	0.40	13.00	101	345010
	45°	CC..09T3..	40.00	SCSCR10CK-09	32.00	7.50	10.00	10.00	13.00	14.50	0.80	17.00	103	345005

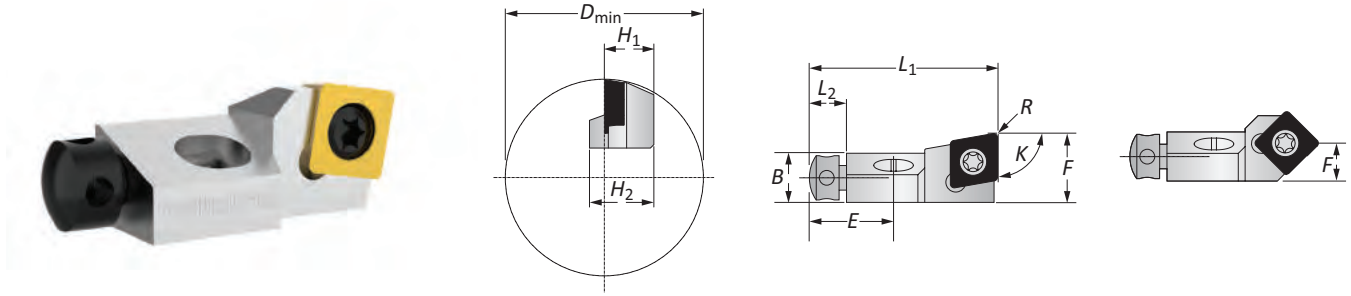

Compact Lay Down Cartridges | Insert Form 112

Diameter Range: ≥40.00 mm



Holder Type	K	ISO	D _{min} Boring Range	Designation	Insert Holder								Insert Form	Part No.
					L ₁	L ₂	B	H ₁	H ₂	F	R Radius	E		
	80°	SC..09T3..	40.00	SSOCR10CK-09	38.00	7.50	10.00	10.00	13.00	12.50	0.80	17.00	112	345019
	75°	SC..09T3..	40.00	SSRCR10CK-09	38.00	7.50	10.00	10.00	13.00	11.70	0.80	17.00	112	345018
	70°	SC..09T3..	40.00	SSPCR10CK-09	38.00	7.50	10.00	10.00	13.00	11.00	0.80	17.00	112	345017
	60°	SC..09T3..	40.00	SSTCR10CK-09	38.00	7.50	10.00	10.00	13.00	9.70	0.80	17.00	112	345016
	45°	SC..09T3..	40.00	SSSCR10CK-09	32.00	7.50	10.00	10.00	13.00	14.00	0.80	17.00	112	345015

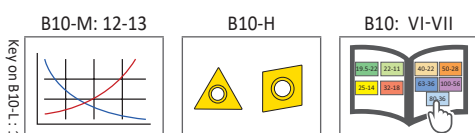

Key on B10-L-1

 = Metric (mm)
Inserts sold separately

Tangential Compact Lay Down Cartridges | Insert Forms 04 & 05

Diameter Range: $\geq 2.125''$ (54.00 mm)

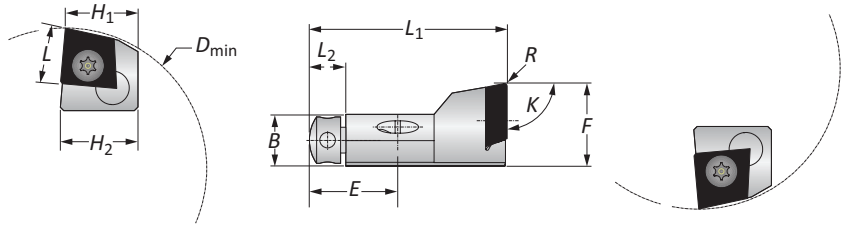
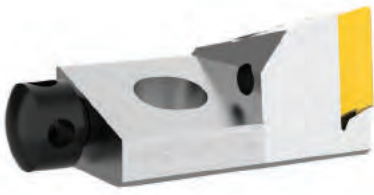

Insert Form 04, 05 Insert Holders

Holder Type	K	D _{min} Boring Range	Insert Holder								Holder Cutting Form	L	Insert Form	Part No.
			L ₁	L ₂	B	H ₁	H ₂	F	R Radius	E				
	90°	54.00	38.00	7.50	10.00	14.00	15.00	16.00	0.50	17.00	Right	10.50	04	345023
	90°	54.00	38.00	7.50	10.00	14.00	15.00	16.00	0.50	17.00	Left	10.50	04	345025
	90°	70.00	45.00	8.00	14.00	19.00	20.00	22.00	0.50	20.00	Right	14.50	05	345020
	90°	70.00	45.00	8.00	14.00	19.00	20.00	22.00	0.50	20.00	Left	14.50	05	345022

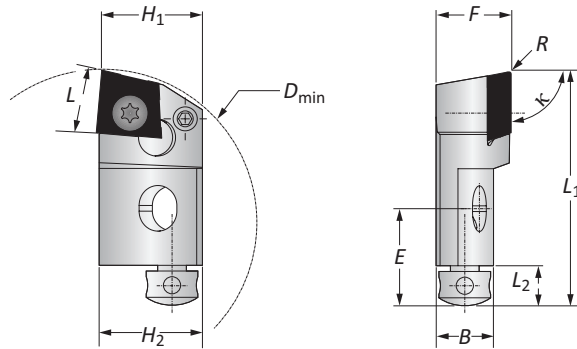
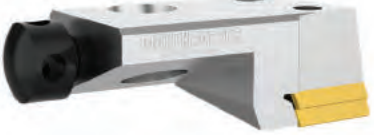

Insert Form 04, 05 Radial Cutting Insert Holders

Holder Type	K	D _{min} Boring Range	Insert Holder								Holder Cutting Form	L	Insert Form	Part No.
			L ₁	L ₂	B	H ₁	H ₂	F	R Radius	E				
	90°	54.00	41.00	7.50	10.00	17.00	18.00	13.00	0.50	17.00	Right	10.50	04	345024
	90°	70.00	50.00	8.00	14.00	21.00	22.00	17.00	0.50	20.00	Right	14.50	05	345021

B10-M: 12-13 B10-H B10: VI-VII

Key on B10-L: 1

= Metric (mm)
Inserts sold separately



Compact Lay Down Cartridge Mounting Dimensions

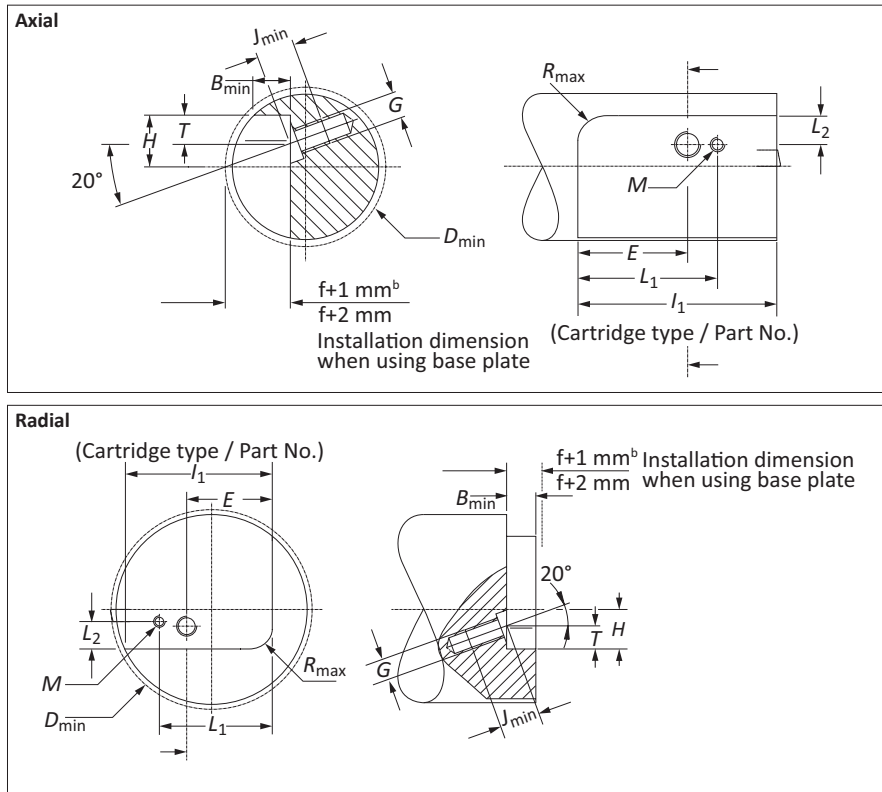

	Installation Dimensions				Mounting Thread and Base Plate							Cartridge Type
	D_{min}	H	R_{max}	B_{min}	E	L_1	T	L_2	G	M	J_{min}	
m	25.00	8.00	2.00	6.50	13.00	18.50	4.50	4.20	M4	M2	8.00	XXXXX 08CK ^{1,2}
	40.00	10.00	2.50	10.00	17.00	24.50	5.00	4.70	M6	M3	11.00	XXXXX 10CK
	50.00	12.00	5.50	14.00	20.00	28.00	6.00	5.70	M6	M3	12.00	XXXXX 12CK
	55.00	14.00	5.50	16.00	23.50	33.00	6.00	7.20	M8	M3	13.00	XXXXX 14CK
	70.00	20.00	6.50	14.00	20.00	27.50	6.00	11.20	M8	M3	15.00	345020
	70.00	22.00	6.50	14.00	20.00	28.00	6.00	11.20	M8	M3	15.00	345021*
	70.00	20.00	6.50	14.00	20.00	27.50	6.00	11.20	M8	M3	15.00	345022
	54.00	15.00	3.00	10.00	17.00	23.50	5.00	9.70	M6	M3	11.00	345023
	54.00	18.00	3.00	10.00	17.00	24.00	5.00	9.20	M6	M3	11.00	345024*
	54.00	15.00	3.00	10.00	17.00	23.50	5.00	9.70	M6	M3	11.00	345025

*Radial

1. From D_{min} 25 mm - 32 mm, the short clamp holder is 0.5 mm from the middle.
2. Installation with base plate.

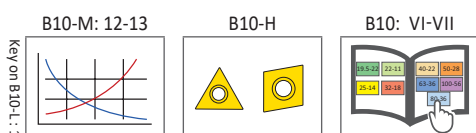

m = Metric (mm)
Inserts sold separately

Compact Lay Down Cartridges Accessories

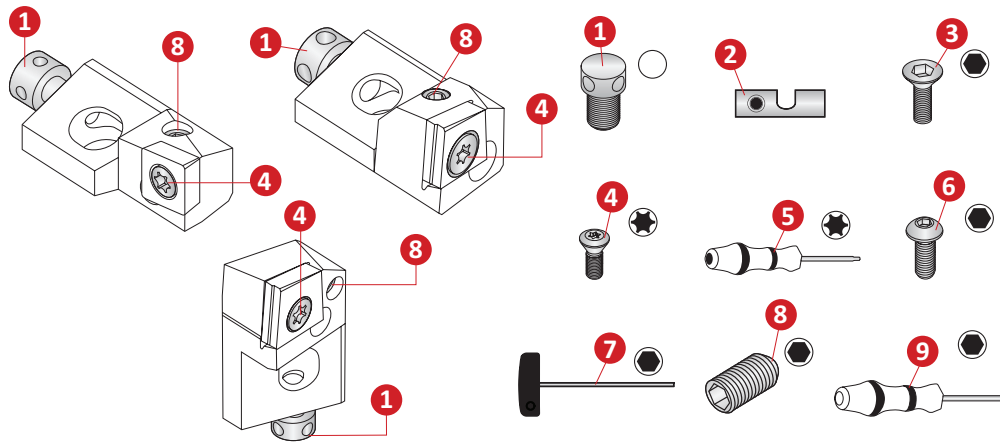

Insert Holder Part No.	1 Axial Barrel Screw	2 Shim	3 Insert Screw	4 Insert Screw	5 Torx Driver	6 Holder Fixing Screw	7 Hex Driver	8 Radial Set Screw	9 Hex Driver
345001	215742	345201	215461	115676	115590	215343	415577	114224	215472
345002	415299	345202	116433	115673	115664	215634	415164	070161	215473
345003	215250	345203	116433	415298	215150	215431	415164	215467	115575
345004	215265	345204	116433	215149	215150	315476	415165	215467	115575
345005	415299	345216	116433	115673	115664	215634	415164	070161	215473
345006	415299	345218	116433	115673	115664	215634	415164	070161	215473
345007	415299	345208	116433	115673	115664	215634	415164	070161	215473
345008	415299	345208	116433	115673	115664	215634	415164	070161	215473
345009	415299	345202	116433	115673	115664	215634	415164	070161	215473
345010	215742	345211	215461	115676	115590	215343	415577	114224	215472
345011	215742	345211	215461	115676	115590	215343	415577	114224	215472
345012	215742	345213	215461	115676	115590	215343	415577	114224	215472
345013	215742	345213	215461	115676	115590	215343	415577	114224	215472
345014	215742	345201	215461	115676	115590	215343	415577	114224	215472
345015	415299	345215	116433	115673	115664	215634	415164	070161	215473
345016	415299	345216	116433	115673	115664	215634	415164	070161	215473
345017	415299	345218	116433	115673	115664	215634	415164	070161	215473
345018	415299	345218	116433	115673	115664	215634	415164	070161	215473
345019	415299	345208	116433	115673	115664	215634	415164	070161	215473
345020	215250	345220	116433	415949	215150	315476	415165	215467	115575
345021	215250	345221	116433	415949	215150	315476	415165	215104	115575
345022	215250	345222	116433	415949	215150	315476	415165	215467	115575
345023	415299	345223	116433	415977	115664	215634	415164	415280	215473
345024	415299	345224	116433	415977	115664	215634	415164	070161	215473
345025	415299	345225	116433	415977	115664	215634	415164	415280	215473

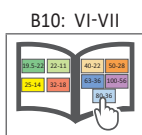
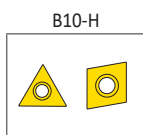
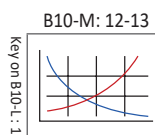

m = Metric (mm)
Inserts sold separately

SECTION

B10-M

Accessories / Technical Information



Your safety and the safety of others is very important. This catalogue contains important safety messages. Always read and follow all safety precautions.



This triangle is a safety hazard symbol. It alerts you to potential safety hazards that can cause tool failure and serious injury.

When you see this symbol in the catalogue, look for a related safety message that may be near this triangle or referred to in the nearby text.

There are safety signal words also used in the catalogue. Safety messages follow these words.

⚠ WARNING

WARNING (shown above) means that failure to follow the precautions in this message could result in tool failure and serious injury.

NOTICE means that failure to follow the precautions in this message could result in damage to the tool or machine but not result in personal injury.

NOTE and **IMPORTANT** are also used. These are important that you read and follow but are not safety-related.

Visit www.alliedmachine.com for the most up-to-date information and procedures.

Applicable Industries



Aerospace



Agriculture



Automotive



Firearms



General
Machining



Oil & Gas



Renewable
Energy

Reference Icons

The following icons will appear throughout the catalogue to help you navigate between products.

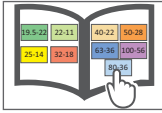

MVS Connection Color Guide

Detailed instructions and information regarding the MVS connection(s)

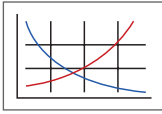

Recommended Cutting Data

Speed and feed recommendations for optimum and safe boring

Accessories and Technical Information Table of Contents

Threaded Taper Pins 2 - 3

Clamping Pieces 4

Heavy Metal Balancing Screws 5

Torque Drivers and Wrenches 6

Torque Driver Set and Wrench Set 7

Technical Information

Guidelines for not Exceeding Recommended Length-to-diameter Ratio 8 - 10

Calculating Tool Assembly Weight 11

Recommended Cutting Data

Metric 12 - 13

Accessories

Threaded Taper Pins for MVS Connections

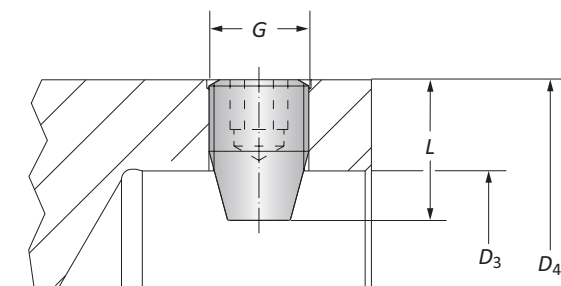

	Connection	Taper Pin		Service Key	Steel	Titanium
	$D_4 D_3$	G	L		Part No.	Part No.
E	19.5 - 11	M5 x 0.5	6.50	s2.5 / A	115949	-
	22 - 11	M5 x 0.5	8.30	s2.5 / A	215375	-
m	25 - 14	M8 x 1.0	8.30	s4 / B	132174	-
	32 - 18	M8 x 1.0	10.40	s4 / B	132142	-
	40 - 22	M10 x 1.0	14.50	s5 / B	133113	-
	50 - 28	M12 x 1.0	16.70	s6 / B	132145	415334
	63 - 36	M16 x 1.5	19.80	s8 / B	132146	415336
F	80 - 36	M16 x 1.5	28.80	s8 / B	132191	415335
	100 - 56	M24 x 2.0	34.00	s12 / B	215470	415337

NOTE: Steel or titanium taper pins are used in balancing the Alu-Line tooling.

Accessories

Threaded Taper Pins for MVS Connections

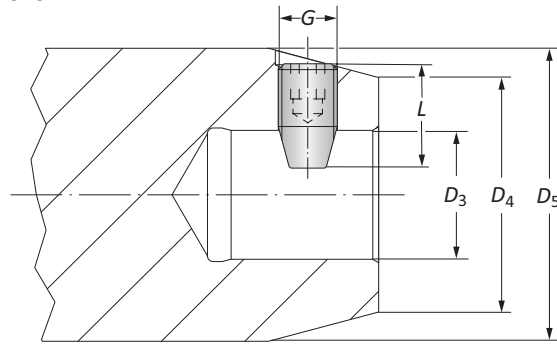

Connection <i>D₄ D₃</i>	Taper Pin			Service Key	Steel	Titanium
	<i>G</i>	<i>L</i>	<i>D₅</i>		Part No.	Part No.
22 - 11	M5 x 0.5	8.30	32.00	s2.5 / A	215375	-
22 - 11	M5 x 0.5	16.00	40.00	s2.5 / A	215376	-
22 - 11	M5 x 0.5	16.00	50.00	s2.5 / A	215376	-
22 - 11	M5 x 0.5	16.00	63.00	s2.5 / A	215376	-
25 - 14	M8 x 1.0	10.40	32.00	s4 / B	132142	-
25 - 14	M8 x 1.0	10.40	36.00	s4 / B	132142	-
32 - 18	M8 x 1.0	10.40	35.00	s4 / B	132142	-
32 - 18	M8 x 1.0	14.50	37.00	s4 / B	132143	-
32 - 18	M8 x 1.0	14.50	40.00	s4 / B	132143	-
32 - 18	M8 x 1.0	14.50	46.00	s4 / B	132143	-
40 - 22	M10 x 1.0	14.50	40.00	s5 / B	133113	-
40 - 22	M10 x 1.0	17.80	47.00	s5 / B	132144	-
40 - 22	M10 x 1.0	17.80	50.00	s5 / B	132144	-
50 - 28	M12 x 1.0	16.70	63.00	s6 / B	132145	415334
63 - 36	M16 x 1.5	19.80	80.00	s8 / B	132146	415336

NOTE: Steel or titanium taper pins are used in balancing the Alu-Line tooling.

A
B
C
D
E
F
G
H
I
J
K
L
M
INDEX

Accessories

Clamping Pieces for MVS Connection 100 - 56 | D 60 / D 40 Connections

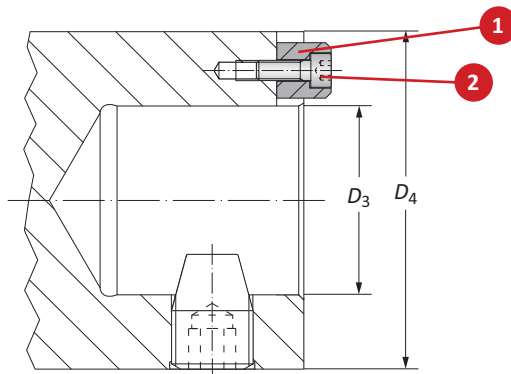

Clamping Pieces for MVS 100 - 56

Connection	1 Torque			2 Cap Screw		
	Service Key	D x L	Part No.	Service Key	D x L	Part No.
100 - 56	-	-	115641	S5 / B	M6 x 1 x 16	115147

Clamping Pieces for D 60 / D 40

Connection	1 Torque
	Part No.
D 60	115643 (125 mm)
D 60	KW31562 (110 mm)
D 40	117143

Clamping Pieces for D 60 / D 40

Connection	2 Cap Screw		
	Service Key	D x L	Part No.
D 60	s10 / B	M12 x 1.75 x 25	115237
D 40	s5 / B	M6 x 1 x 16	115147

Clamping Pieces for D 60 / D 40

Connection	3 Cap Screw		
	Service Key	D x L	Part No.
D 60	s14 / C	M16 x 2 x 80	115170 ⁽¹⁾
D 60	s14 / C	M16 x 2 x 55	215189 ⁽²⁾
D 40	s10 / B	M12 x 1.75 x 75	315186 ⁽³⁾
D 40	s10 / B	M12 x 1.75 x 50	077104 ⁽²⁾

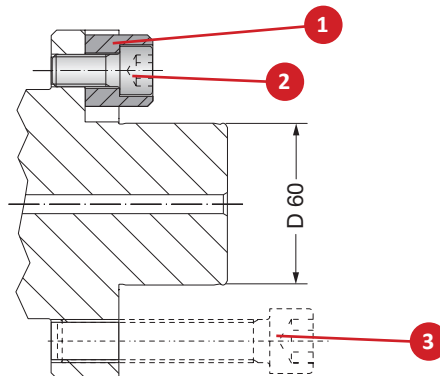

⁽¹⁾ To mount boring tools above $\varnothing 200.00$ mm, see section B10-F

⁽²⁾ Cap screws used for mounting cutter heads to DIN 1830

⁽³⁾ $\varnothing 200.00$ mm - 520.00 mm

Accessories

Heavy Metal Balancing Screws

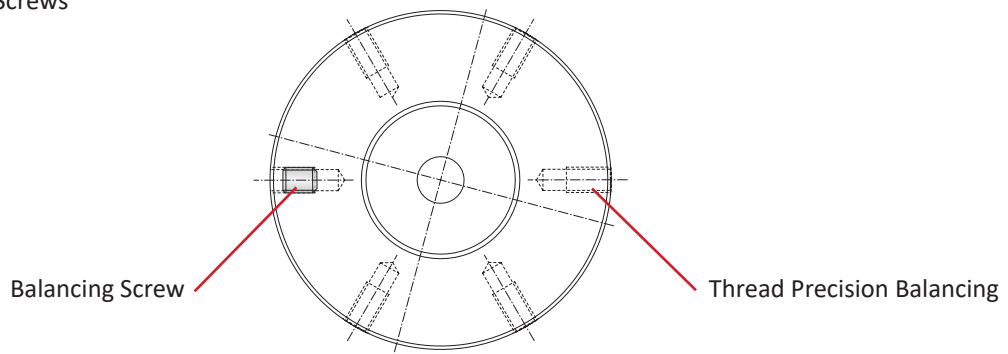

Balancing Screw		
Nominal Size	Service Key	Part No.
M5 x 0.8 x 6	0.8 x 4 / K	415573
M6 x 1 x 6	0.8 x 4 / K	415284
M6 x 1 x 8	0.8 x 4 / K	415341
M6 x 1 x 10	0.8 x 4 / K	415283
M8 x 1.25 x 8	1.2 x 6.5 / K	415285
M8 x 1.25 x 10	1.2 x 6.5 / K	415286
M8 x 1.25 x 12	1.2 x 6.5 / K	415287

Accessories

Torque Drivers | Wrenches

Service Keys for Insert Holders and Fixing Screws (Type A, B, C, F)

Service Key	Part No.
s1.5 / A	215472
s2 / A	215473
s2 / B	415761
s2.5 / A	115575
s2.5 / B	415577
s3 / A	115630
s3 / B	415578
s4 / B	115576
s4 / F	315265
s4 / B	415164
s5 / B	115577
s5 / B	415165
s6 / B	115578
s8 / B	115579
s8 / C	415611
s10 / B	115580
s12 / B	215638
s14 / C	215639

Fixed Torque Driver (Type B, H)

Service Key	Part No.
T6 / H	115537
T7 / H	115591
T8 / H	115590
T15 / H	115664
T20 / H	215150
T25 / B	415121

Torque Driver (Type H)

Service Key	Part No.
T6 / H	415507
T7 / H	415508
T8 / H	415514
T15 / H	415510
T20 / H	415543

Torque Driver (Type K)

Service Key	Part No.
0.5 x 3 / K	315322
0.8 x 4 / K	415579
1.2 x 6.5 / K	415580

Wrench (Type P)

Service Key	Part No.
13 / P	315689
15 / P	315690
19 / P	315691

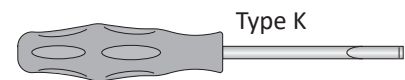
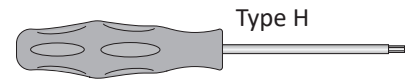
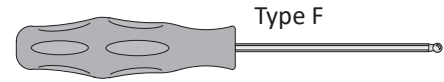
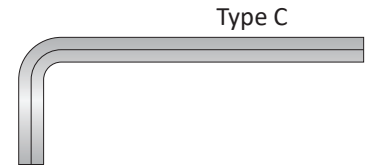
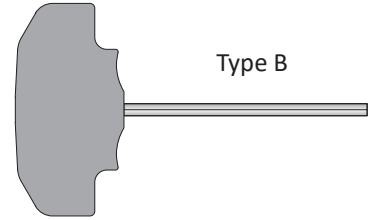
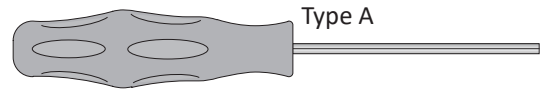

Accessories

Torque Driver Set | 25 Piece Wrench Set



NOTE: Torque driver set pictured

Torque Driver Set: Torx® Bits, Hexagon Bits, Flat Blade Bits

Type	Pieces	Size	Set Part No.
Flat Blade Bit	1	0.3 - 1.2 (Nm)	103086
Flat Blade Bit	1	1.2 - 3.0 (Nm)	
Flat Blade Bit	1	4.0 - 8.0 (Nm)	
Torque Driver	3	T6	
Torque Driver	3	T7	
Torque Driver	3	T8	
Torque Driver	1	T16	
Torque Driver	1	T20	
Torque Driver	1	T25	
Hexagon Bit	3	s2	
Hexagon Bit	3	s2.5	
Hexagon Bit	2	s3	
Hexagon Bit	2	s4	
Hexagon Bit	1	s5	
Flat Blade Bit	1	0.5 x 3.0	

25 Piece Wrench Set

Type	Size	Set Part No.
A	s1.5 / s2 / s2.5 / s3 / s4	103025
B	s4 / s5 / s6 / s8 / s10 / s12 / s14	
C	s7	
F	s4	
H	T6 / T7 / T8 / T15 / T20 / T25	
K	0.5 x 3	
P	s13 / s15 / s19	

Guidelines for not Exceeding Recommended Length-to-diameter Ratio

To calculate, see graphics below:

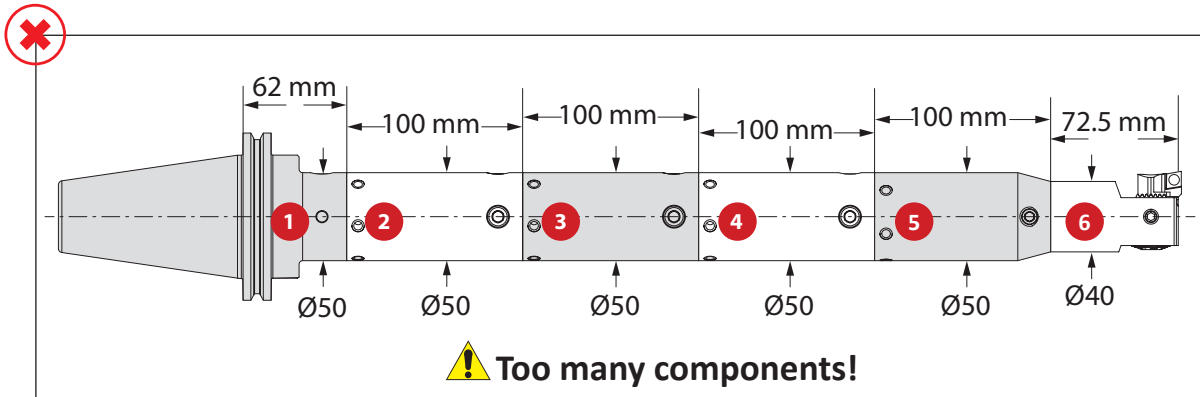

NOTE: Length-to-diameter ratio is calculated using body diameters not cutting diameter.

NOTE: Do not exceed recommended 10xD length-to-diameter ratio or exceed four total components (including shank)

Step 1: Find L : D by component

- 1. $1.2 = 62/50$
- 2. $2.0 = 100/50$
- 3. $2.0 = 100/50$
- 4. $2.0 = 100/50$
- 5. $2.0 = 100/50$
- 6. $1.8 = 72.5/40$

Step 2: Add each L : D Average

- 1.2
- 2.0
- 2.0
- 2.0
- 2.0
- 2.0
- + 1.8
- 11.0 = L : D ratio**

Too long with too many components!

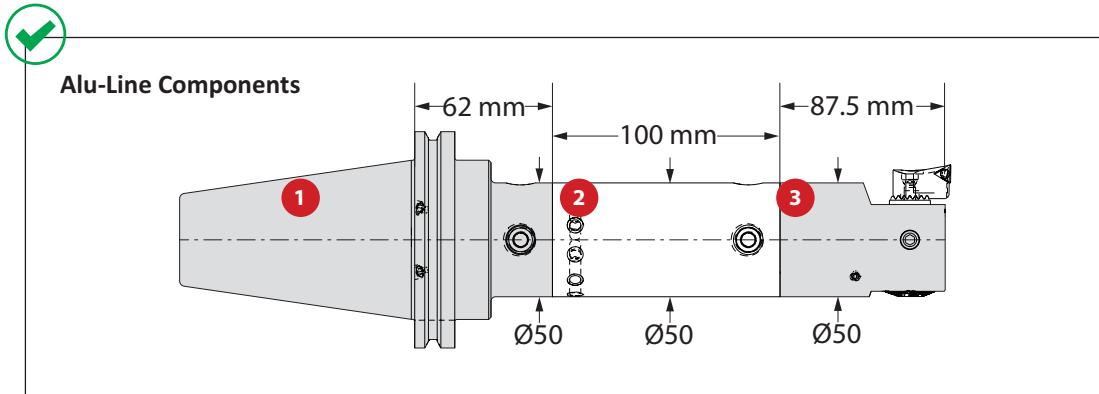

NOTE: Length-to-diameter ratio is calculated using body diameters not cutting diameter.

NOTE: Do not exceed recommended 5xD length-to-diameter ratio when using Alu-Line (Aluminium) components or exceed four total components (including shank).

Step 1: Find L : D by component

- 1. $1.2 = 62/50$
- 2. $2.0 = 100/50$
- 3. $1.8 = 87.5/50$

Step 2: Add each L : D average

- 1.2
- 2.0
- + 1.8
- 5.0 = L : D ratio**

⚠ WARNING Tool failure can cause serious injury. To prevent:

- Do not exceed recommended 10xD length-to-diameter ratio or exceed four total components (including shank)
- When using Alu-Line components, do not exceed recommended 5xD length-to-diameter ratio
- When using tool steel components, do not exceed recommended 6xD length-to-diameter ratio
- When using heavy metal components, do not exceed recommended 8xD length-to-diameter ratio
- When using a carbide shank, do not exceed recommended 9xD length-to-diameter ratio
- When using a NOVI^{TECH} module, do not exceed recommended 10xD length-to-diameter ratio

Factory technical assistance is available for your specific applications through our Application Engineering department. email: engineering.eu@alliedmachine.com

Guidelines for not Exceeding Recommended Length-to-diameter Ratio

To calculate, see graphics below:

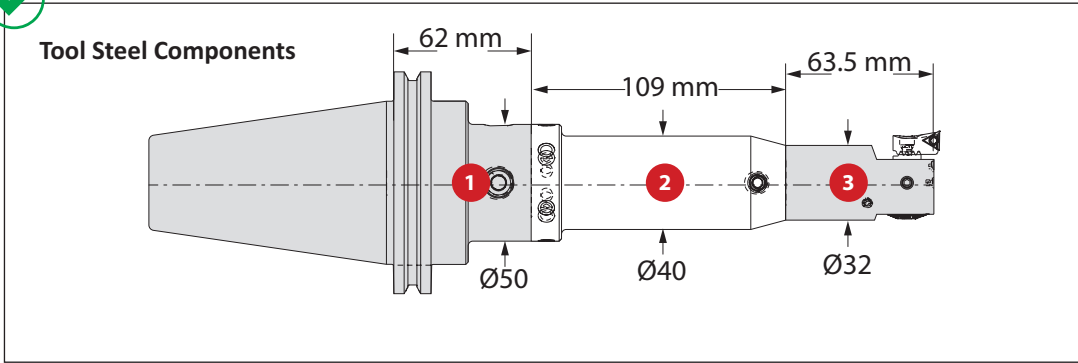

NOTE: Length-to-diameter ratio is calculated using body diameters not cutting diameter.

NOTE: When using steel components, do not exceed recommended 6xD length-to-diameter ratio or exceed four total components (including shank).

Step 1: Find L : D by component

1 $1.2 = 62/50$

2 $2.7 = 109/40$

3 $2.0 = 63.5/32$

Step 2: Add each L : D average

1.2

2.7

+ 2.0

5.9 = L : D ratio

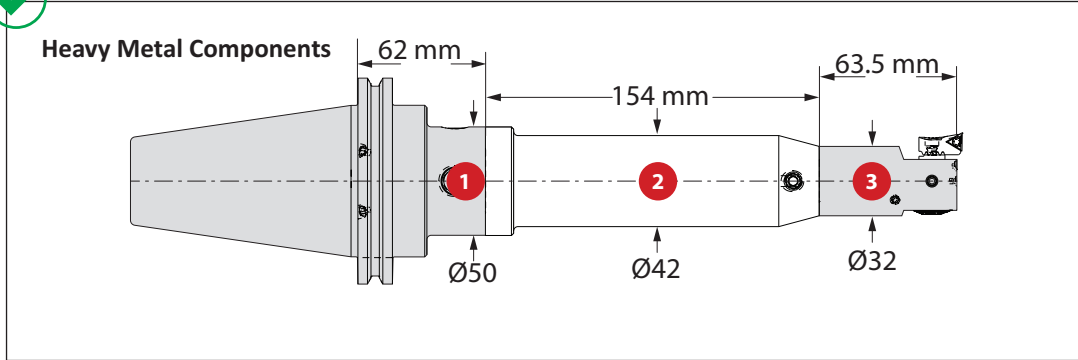

NOTE: Length-to-diameter ratio is calculated using body diameters not cutting diameter.

NOTE: When using heavy metal components, do not exceed recommended 8xD length-to-diameter ratio or exceed four total components (including shank).

Step 1: Find L : D by component

1 $1.2 = 62/50$

2 $3.6 = 154/42$

3 $2.0 = 63.5/32$

Step 2: Add each L : D average

1.2

3.6

+ 2.0

6.8 = L : D ratio



1 WARNING Tool failure can cause serious injury. To prevent:

- Do not exceed recommended 10xD length-to-diameter ratio or exceed four total components (including shank)
- When using Alu-Line components, do not exceed recommended 5xD length-to-diameter ratio
- When using tool steel components, do not exceed recommended 6xD length-to-diameter ratio
- When using heavy metal components, do not exceed recommended 8xD length-to-diameter ratio
- When using a carbide shank, do not exceed recommended 9xD length-to-diameter ratio
- When using a NOVI^{TECH} module, do not exceed recommended 10xD length-to-diameter ratio

Factory technical assistance is available for your specific applications through our Application Engineering department. email: engineering.eu@alliedmachine.com

Guidelines for not Exceeding Recommended Length-to-diameter Ratio

To calculate, see graphics below:

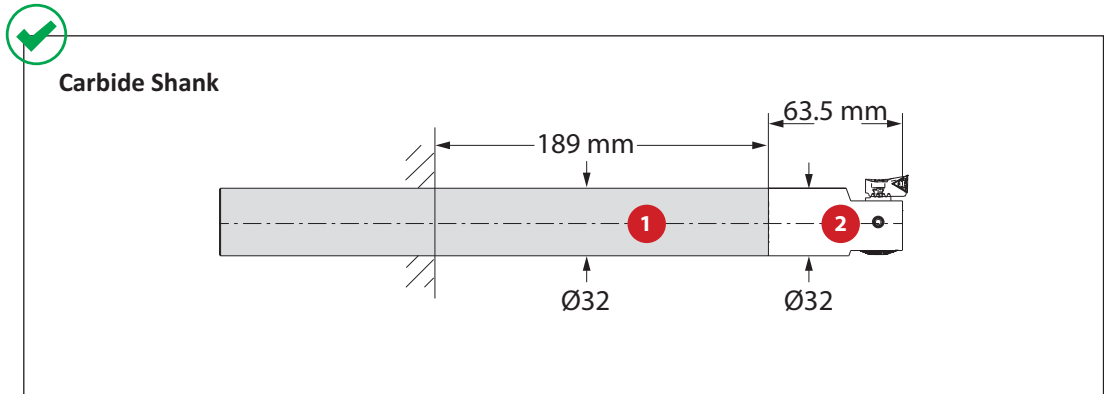

NOTE: Length-to-diameter ratio is calculated using body diameters not cutting diameter.

NOTE: When using carbide shank components, do not exceed recommended 9xD length-to-diameter ratio or exceed 4 total components.

Step 1: Find L : D by component

- 1 8.1 = 189/32
- 2 2.0 = 63.5/32

Step 2: Add each L : D average

$$\begin{array}{r}
 5.9 \\
 + 2.0 \\
 \hline
 7.9 = L : D \text{ ratio}
 \end{array}$$

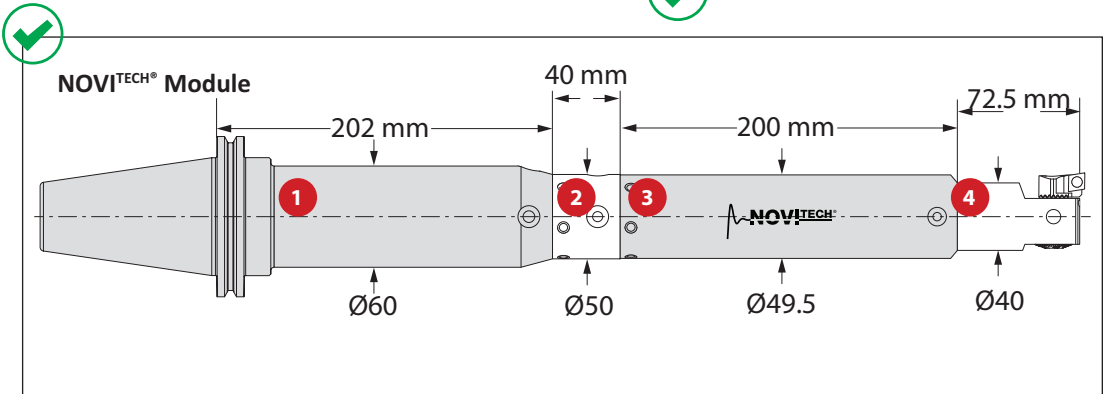

NOTE: Length-to-diameter ratio is calculated using body diameters not cutting diameter.

NOTE: Do not exceed recommended 10xD length-to-diameter ratio when using NOVI^{TECH} intermediate modules or exceed four total components (including shank)

NOTE: The NOVI^{TECH} intermediate module should always be assembled as close as possible to the cutting edge (i.e. the next component behind the boring head)

Step 1: Find L : D by component

- 1 3.3 = 202/60
- 2 0.8 = 40/50
- 3 4.0 = 200/49.5
- 4 1.8 = 72.5/40

Step 2: Add each L : D average

$$\begin{array}{r}
 3.3 \\
 0.8 \\
 4.0 \\
 + 1.8 \\
 \hline
 9.9 = L : D \text{ ratio}
 \end{array}$$

Component	Length-to-diameter Ratio
Alu-Line	5xD
Tool Steel	6xD
Heavy Metal	8xD
Carbide	9xD
NOVI ^{TECH}	10xD

1. WARNING Tool failure can cause serious injury. To prevent:

- Do not exceed recommended 10xD length-to-diameter ratio or exceed four total components (including shank)
- When using Alu-Line components, do not exceed recommended 5xD length-to-diameter ratio
- When using tool steel components, do not exceed recommended 6xD length-to-diameter ratio
- When using heavy metal components, do not exceed recommended 8xD length-to-diameter ratio
- When using a carbide shank, do not exceed recommended 9xD length-to-diameter ratio
- When using a NOVI^{TECH} module, do not exceed recommended 10xD length-to-diameter ratio

Factory technical assistance is available for your specific applications through our Application Engineering department. email: engineering.eu@alliedmachine.com

Calculating Tool Assembly Weight

To calculate, see graphics below:

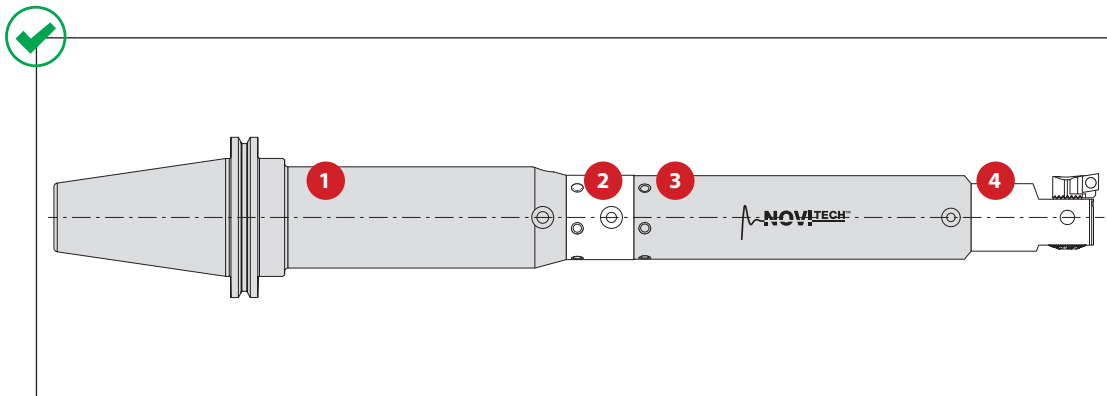

Step 1: Find weight for each component circled in the example table below

Example:

MVS Connection	Boring Range	4 Boring Head				Weight	Part No.
		X_1	X_2	L_2	D_5		
$D_1 \& D_2$ 40 - 22	53.01 - 65.98	75.00	39.00	72.50	-	0.70 (kg)	320004

Step 2: Calculate total assembly weight

$$\begin{array}{r}
 1 \ 6.6 \text{ kg} \\
 2 \ 0.6 \text{ kg} \\
 3 \ 3.5 \text{ kg} \\
 + 4 \ 0.7 \text{ kg} \\
 \hline
 11.4 \text{ kg}
 \end{array}$$

Step 3: Consult machine tool builder to ensure tool assembly weight does not exceed machine capabilities.

WARNING Exceeding weight capacity for machine tool spindle and tool changer can cause machine damage and/or serious injury. To prevent:
 -Consult machine tool builder for machine's weight limitations.
 Factory technical assistance is also available for specific applications through our Application Engineering department. *email: engineering.eu@alliedmachine.com*

Recommended Cutting Data | Metric (mm)

ISO	Material	(BHN) Hardness	Grade	*Speed M / Min	Recommended Feed (mm / tooth) Nose Radii			
					0.1 mm	0.2 mm	0.4 mm	0.9 mm
P	Free-Machining Steel 1118, 1215, 12L14, etc.	100 - 250	Carbide	150 - 300	0.02 - 0.08	0.05 - 0.13	0.10 - 0.15	0.15 - 0.23
	Low-Carbon Steel 1010, 1020, 1025, 1522, 1144, etc.	85 - 275	Carbide	145 - 280	0.02 - 0.05	0.05 - 0.10	0.08 - 0.13	0.13 - 0.20
	Medium-Carbon Steel 1030, 1040, 1050, 1527, 1140, 1151, etc.	125 - 325	Carbide	145 - 280	0.02 - 0.05	0.05 - 0.10	0.08 - 0.13	0.13 - 0.20
	Alloy Steel 4140, 5140, 8640, etc.	125 - 375	Carbide	120 - 215	0.02 - 0.05	0.05 - 0.10	0.08 - 0.13	0.13 - 0.20
	High-Strength Alloy 4340, 4330V, 300M, etc.	225 - 400	Carbide	100 - 180	0.02 - 0.05	0.05 - 0.10	0.08 - 0.13	0.13 - 0.20
	Structural Steel A36, A285, A516, etc.	100 - 350	Carbide	145 - 280	0.02 - 0.05	0.05 - 0.10	0.08 - 0.13	0.13 - 0.20
	Tool Steel H-13, H-21, A-4, O-2, S-3, etc.	150 - 250	Carbide	100 - 180	0.02 - 0.05	0.05 - 0.08	0.08 - 0.10	0.10 - 0.15
S	High-Temp Alloy Hastelloy B, Inconel 600, etc.	140 - 310	Carbide	30 - 70	0.02 - 0.05	0.05 - 0.08	0.08 - 0.13	0.10 - 0.15
	Titanium Alloy	140 - 310	Carbide	40 - 90	0.02 - 0.05	0.05 - 0.08	0.08 - 0.13	0.10 - 0.15
	Aerospace Alloy S82	185 - 350	Carbide	40 - 90	0.02 - 0.05	0.05 - 0.08	0.08 - 0.13	0.10 - 0.15
M	Stainless Steel 400 Series 416, 420, etc.	185 - 350	Carbide	90 - 160	0.02 - 0.05	0.05 - 0.10	0.08 - 0.10	0.10 - 0.15
	Stainless Steel 300 Series 304, 316, 17-4PH, etc.	135 - 275	Carbide	90 - 160	0.02 - 0.05	0.05 - 0.10	0.08 - 0.10	0.10 - 0.15
	Super Duplex Stainless Steel	135 - 275	Carbide	90 - 160	0.02 - 0.05	0.05 - 0.10	0.08 - 0.10	0.10 - 0.15

*Not to exceed max recommended RPM for boring head found in corresponding Wohlhaupter Operation Manual

Deep Hole Boring Speed Adjustment

⚠ For Dynamic Boring Tool Length

Boring Type	7xD	8xD	9xD	10xD
Roughing	❖	❖	❖	❖
Finishing	0.70	0.50	0.30	❖

❖ Contact our Application Engineering department for assistance when boring these depths without NOVI^{TECH}.

Deep Hole Boring Speed Adjustment

⚠ For Dynamic Boring Tool NOVI^{TECH} Length

Boring Type	8xD	9xD	10xD
Roughing	0.80	0.60	0.40
Finishing	0.90	0.70	0.50

*Not to exceed recommended RPM printed on NOVI^{TECH} module

Recommended Speed Example

If the recommended speed for a finish boring assembly under 5xD is 120 M/Min, then the speed for a 10xD finish boring assembly in the same application would be 60 M/Min (120 M/Min x 0.50 = 60 M/Min)

5xD = 120 M/Min

10xD = 60 M/Min

IMPORTANT: Max spindle speed refers to maximum possible speed for individual boring head and is not a recommended parameter. Factory technical assistance is available for your specific applications through our Application Engineering department. *email: engineering.eu@alliedmachine.com*

⚠ WARNING Tool failure can cause serious injury. To prevent:

- Do not exceed recommended 10xD length-to-diameter ratio or exceed four total components (including shank)
- When using Alu-Line components, do not exceed recommended 5xD length-to-diameter ratio
- When using tool steel components, do not exceed recommended 6xD length-to-diameter ratio
- When using heavy metal components, do not exceed recommended 8xD length-to-diameter ratio
- When using a carbide shank, do not exceed recommended 9xD length-to-diameter ratio
- When using a NOVI^{TECH} module, do not exceed recommended 10xD length-to-diameter ratio

Factory technical assistance is available for your specific applications through our Application Engineering department. *email: engineering.eu@alliedmachine.com*

Recommended Cutting Data | Metric (mm)

ISO	Material	(BHN) Hardness	Grade	*Speed M / Min	Recommended Feed (mm / tooth) Nose Radii			
					0.1 mm	0.2 mm	0.4 mm	0.9 mm
H	Wear Plate Hardox®, AR400, T-1, etc.	400 - 600	Carbide	30 - 60	0.02 - 0.05	0.05 - 0.08	0.08 - 0.10	0.10 - 0.15
			CBN	70 - 180	0.02 - 0.05	0.05 - 0.08	0.08 - 0.10	0.10 - 0.15
	Hardened Steel	300 - 500	Carbide	40 - 80	0.02 - 0.05	0.05 - 0.08	0.08 - 0.10	0.10 - 0.15
			CBN	70 - 180	0.02 - 0.05	0.05 - 0.08	0.08 - 0.10	0.10 - 0.15
K	SG / Nodular Cast Iron	120 - 320	Carbide	145 - 260	0.02 - 0.05	0.05 - 0.10	0.08 - 0.13	0.13 - 0.20
	Grey / White Iron	180 - 320	Carbide	180 - 320	0.02 - 0.05	0.05 - 0.10	0.08 - 0.13	0.13 - 0.20
			CBN	400 - 1000	0.02 - 0.05	0.05 - 0.10	0.08 - 0.13	0.13 - 0.20
N	Cast Aluminium	30 - 180	Carbide	260 - 850	0.02 - 0.05	0.05 - 0.10	0.08 - 0.13	0.13 - 0.20
			PCD	495 - 1995	0.02 - 0.05	0.05 - 0.10	0.08 - 0.13	0.13 - 0.20
	Wrought Aluminium	30 - 180	Carbide	205 - 600	0.02 - 0.05	0.05 - 0.13	0.10 - 0.15	0.15 - 0.23
	Aluminium Bronze	100 - 250	Carbide	145 - 280	0.02 - 0.05	0.05 - 0.10	0.10 - 0.13	0.13 - 0.20
Brass	100	Carbide	205 - 600	0.02 - 0.05	0.05 - 0.10	0.08 - 0.13	0.13 - 0.20	
Copper	60	Carbide	100 - 180	0.02 - 0.05	0.05 - 0.08	0.08 - 0.10	0.10 - 0.13	

*Not to exceed max recommended RPM for boring head found in corresponding Wohlhaupter Operation Manual

Deep Hole Boring Speed Adjustment

⚠ For Dynamic Boring Tool Length				
Boring Type	7xD	8xD	9xD	10xD
Roughing	❖	❖	❖	❖
Finishing	0.70	0.50	0.30	❖

❖ Contact our Application Engineering department for assistance when boring the depths without NOVI^{TECH}.

Deep Hole Boring Speed Adjustment

⚠ For Dynamic Boring Tool NOVI ^{TECH} Length			
Boring Type	8xD	9xD	10xD
Roughing	0.80	0.60	0.40
Finishing	0.90	0.70	0.50

*Not to exceed recommended RPM printed on NOVI^{TECH} module

Recommended Speed Example

If the recommended speed for a finish boring assembly under 5xD is 120 M/Min, then the speed for a 10xD finish boring assembly in the same application would be 60 M/Min (120 M/Min x 0.50 = 60 M/Min)

5xD = 120 M/Min	10xD = 60 M/Min
-----------------	-----------------

IMPORTANT: Max spindle speed refers to maximum possible speed for individual boring head and is not a recommended parameter. Factory technical assistance is available for your specific applications through our Application Engineering department. *email: engineering.eu@alliedmachine.com*

⚠ WARNING Tool failure can cause serious injury. To prevent:

- Do not exceed recommended 10xD length-to-diameter ratio or exceed four total components (including shank)
- When using Alu-Line components, do not exceed recommended 5xD length-to-diameter ratio
- When using tool steel components, do not exceed recommended 6xD length-to-diameter ratio
- When using heavy metal components, do not exceed recommended 8xD length-to-diameter ratio
- When using a carbide shank, do not exceed recommended 9xD length-to-diameter ratio
- When using a NOVI^{TECH} module, do not exceed recommended 10xD length-to-diameter ratio

Factory technical assistance is available for your specific applications through our Application Engineering department. *email: engineering.eu@alliedmachine.com*

A
B
C
D
E
F
G
H
I
J
K
L
M
INDEX

Part No.	Page
071779...	B10-I: 24
071780...	B10-I: 24
071781...	B10-I: 24
071782...	B10-I: 24
071783...	B10-I: 24
071784...	B10-I: 24
071785...	B10-I: 24
071786...	B10-I: 24
071787...	B10-I: 24
071788...	B10-I: 24
071789...	B10-I: 24
071790...	B10-F: 15, B10-I: 24
071791...	B10-I: 24
071792...	B10-I: 24
071793...	B10-F: 15, B10-I: 24
071794...	B10-I: 24
071795...	B10-F: 15, B10-I: 24
071796...	B10-I: 24
071797...	B10-I: 24
071798...	B10-F: 15, B10-I: 24
071799...	B10-I: 24
071800...	B10-I: 24
071801...	B10-I: 24
071826...	B10-I: 27
071827...	B10-I: 27
071828...	B10-I: 27
071829...	B10-I: 27
071830...	B10-I: 27
071831...	B10-I: 27
071832...	B10-I: 27
071833...	B10-I: 27
071834...	B10-I: 27
071835...	B10-I: 27
071836...	B10-I: 27
071837...	B10-I: 27
071901...	B10-I: 26
071902...	B10-I: 26
071903...	B10-I: 26
071904...	B10-I: 26
071912...	B10-I: 26
071913...	B10-I: 26
071914...	B10-I: 26
071915...	B10-I: 26
071916...	B10-I: 26
071917...	B10-I: 26
071918...	B10-I: 26
071919...	B10-I: 26
071920...	B10-I: 26
071921...	B10-I: 26
071922...	B10-I: 26
071923...	B10-I: 26
071924...	B10-I: 26
071925...	B10-I: 26
071926...	B10-I: 26
071927...	B10-I: 26
071928...	B10-I: 26
071929...	B10-I: 26
071930...	B10-I: 26
071931...	B10-I: 26
071932...	B10-I: 26
071933...	B10-I: 26
071934...	B10-I: 26
071935...	B10-I: 26
071936...	B10-I: 26

Part No.	Page
071937...	B10-I: 26
071938...	B10-I: 26
071939...	B10-I: 26
071940...	B10-I: 26
071941...	B10-I: 26
071986...	B10-I: 21
071987...	B10-I: 21
071988...	B10-I: 21
071989...	B10-I: 21
071990...	B10-I: 21
071991...	B10-I: 21
071992...	B10-I: 21
071993...	B10-I: 21
071994...	B10-I: 21
073003...	B10-J: 4
073004...	B10-J: 4
073005...	B10-J: 4
073006...	B10-J: 8, B10-J: 10
073007...	B10-J: 8, B10-J: 10
073008...	B10-J: 8, B10-J: 10
075001...	B10-J: 5
075002...	B10-J: 5
075003...	B10-J: 9, B10-J: 11
075004...	B10-J: 9, B10-J: 11
077104...	B10-M: 4
077110...	B10-G: 25
081041...	B10-A: 8
081042...	B10-A: 8
081043...	B10-A: 8
081044...	B10-A: 8
081045...	B10-A: 8
081046...	B10-A: 8
081047...	B10-A: 8
081048...	B10-A: 8
081049...	B10-A: 8
081050...	B10-A: 8
081053...	B10-A: 8
081055...	B10-A: 9, B10-A: 40
081087...	B10-J: 4
081092...	B10-J: 8, B10-J: 10
081306WHC05...	B10-A: 31, B10-A: 39, B10-A: 54, B10-A: 63
081307WHW04...	B10-A: 31, B10-A: 39, B10-A: 54, B10-A: 63
081308WHC05...	B10-A: 31, B10-A: 39, B10-A: 54, B10-A: 63
081309WHC05...	B10-A: 31, B10-A: 39, B10-A: 54, B10-A: 63
081310WHC05...	B10-A: 31,

Part No.	Page
	B10-A: 39, B10-A: 54, B10-A: 63
081310WHW04...	B10-A: 31, B10-A: 39, B10-A: 54, B10-A: 63
081311WHC05...	B10-A: 31, B10-A: 39, B10-A: 54, B10-A: 63
081312WHC05...	B10-A: 31, B10-A: 39, B10-A: 54, B10-A: 63
081313WHC05...	B10-A: 31, B10-A: 39, B10-A: 54, B10-A: 63
081313WHW04...	B10-A: 31, B10-A: 39, B10-A: 54, B10-A: 63
081314WHC05...	B10-A: 31, B10-A: 39, B10-A: 54, B10-A: 63
081315WHC05...	B10-A: 31, B10-A: 39, B10-A: 54, B10-A: 63
081316WHC05...	B10-A: 31, B10-A: 39, B10-A: 54, B10-A: 63
081316WHW04...	B10-A: 31, B10-A: 39, B10-A: 54, B10-A: 63
081317WBN150...	B10-A: 31, B10-A: 39, B10-A: 54, B10-A: 63
081318WBN150...	B10-A: 31, B10-A: 39, B10-A: 54, B10-A: 63
081319WBN150...	B10-A: 31, B10-A: 39, B10-A: 54, B10-A: 63
081320WBN150...	B10-A: 31, B10-A: 39, B10-A: 54, B10-A: 63

Part No.	Page
081321WBN150...	B10-A: 31, B10-A: 39, B10-A: 54, B10-A: 63
081322WBN150...	B10-A: 31, B10-A: 39, B10-A: 54, B10-A: 63
081323WHC05...	B10-A: 39, B10-A: 54, B10-A: 63
081324WHC05...	B10-A: 39, B10-A: 54, B10-A: 63
081341WBN150...	B10-A: 31, B10-A: 39, B10-A: 54, B10-A: 63
081401WHC126...	B10-A: 6, B10-A: 53
081402WHC126...	B10-A: 6, B10-A: 53
081403HC126...	B10-A: 53
081403WHC126...	B10-A: 6, B10-A: 53
081404HC126...	B10-A: 53
081404WHC126...	B10-A: 6, B10-A: 53
081405WHC126...	B10-A: 6, B10-A: 53
081406WHC126...	B10-A: 6, B10-A: 53
081407WHC126...	B10-A: 6, B10-A: 53
081408WHC126...	B10-A: 6, B10-A: 53
089001...	B10-J: 5, B10-J: 9, B10-J: 11
097153...	B10-H: 16
097154...	B10-H: 16
097241...	B10-H: 23
097242...	B10-H: 23
097244...	B10-H: 23
097245...	B10-H: 23
097247...	B10-H: 23
097249...	B10-H: 23
097252...	B10-H: 28
097253...	B10-H: 30
097254...	B10-H: 30
097255...	B10-H: 30
097256...	B10-H: 30
097257...	B10-H: 30
097258...	B10-H: 30

Part No.	Page
097259...	B10-H: 30
097260...	B10-H: 30
097261...	B10-H: 30
097262...	B10-H: 30
097294...	B10-H: 30
097324...	B10-H: 23
097445...	B10-H: 20
097454...	B10-H: 14
097462...	B10-H: 24
097486...	B10-H: 15
097487...	B10-H: 17
097496...	B10-H: 20
097497...	B10-H: 20
097512...	B10-H: 18
097529...	B10-H: 20
097539...	B10-H: 28
097546...	B10-H: 16
097552...	B10-H: 15
097557...	B10-H: 15
097559...	B10-H: 26
097566...	B10-H: 28
097599...	B10-H: 16
097686...	B10-H: 17
097701...	B10-H: 16
097738...	B10-H: 23
097755...	B10-H: 14
097831...	B10-H: 35
097832...	B10-H: 19
097833...	B10-H: 19
097862...	B10-H: 20
097877...	B10-H: 17
097899...	B10-H: 20
097926...	B10-H: 20
097953...	B10-H: 18
097957...	B10-H: 20
098060...	B10-F: 16
098061...	B10-F: 16
098062...	B10-F: 16
098063...	B10-F: 16
098064...	B10-F: 16
098065...	B10-F: 16
098066...	B10-F: 16
098067...	B10-F: 16
098068...	B10-F: 16
098069...	B10-F: 16
098070...	B10-F: 16
098071...	B10-F: 16
098073...	B10-F: 16
099049...	B10-I: 28
099050...	B10-I: 28
099051...	B10-I: 28
099053...	B10-I: 28
099054...	B10-I: 28
099055...	B10-I: 28
271128...	B10-I: 23
271129...	B10-I: 23
271130...	B10-I: 23
271131...	B10-I: 23
271132...	B10-I: 22
271133...	B10-I: 22
271134...	B10-I: 22
271135...	B10-I: 22
271136...	B10-I: 22
271137...	B10-I: 22
502066...	B10-A: 64
1	
103025...	B10-M: 7
103045...	B10-A: 21

Part No.	Page
103046...	B10-A: 20
103047...	B10-A: 23
103048...	B10-A: 22
103049...	B10-A: 25
103050...	B10-A: 24
103051...	B10-A: 27
103052...	B10-A: 26
103061...	B10-A: 73
103062...	B10-A: 74
103063...	B10-A: 75
103064...	B10-A: 76
103065...	B10-A: 77
103066...	B10-A: 78
103080...	B10-A: 80
103081...	B10-A: 79
103086...	B10-M: 7
103088...	B10-A: 48
103089...	B10-A: 49
109109...	B10-F: 33
114224...	B10-A: 19, B10-A: 71, B10-L: 10
115118...	B10-G: 22
115119...	B10-A: 19
115136...	B10-A: 35, B10-B: 27
115147...	B10-A: 18, B10-I: 33, B10-M: 4
115166...	B10-A: 71
115169...	B10-I: 33
115170...	B10-M: 4
115180...	B10-B: 27
115185...	B10-B: 27
115186...	B10-B: 27
115192...	B10-D: 23
115237...	B10-I: 33, B10-M: 4
115249...	B10-B: 27
115280...	B10-D: 23
115288...	B10-C: 7
115341...	B10-I: 33
115342...	B10-I: 33
115343...	B10-I: 33
115344...	B10-I: 33
115345...	B10-I: 33
115346...	B10-I: 33
115347...	B10-I: 33
115348...	B10-I: 33
115407...	B10-D: 23
115470...	B10-A: 19
115505...	B10-B: 15, B10-B: 21
115519...	B10-D: 23
115535...	B10-A: 19, B10-A: 58, B10-A: 72
115537...	B10-A: 19, B10-A: 58, B10-A: 72, B10-H: 14, B10-H: 15, B10-H: 19, B10-M: 6
115575...	B10-A: 19, B10-L: 10, B10-M: 6
115576...	B10-A: 19, B10-A: 58, B10-A: 72,

Part No.	Page
	B10-M: 6
115577...	B10-M: 6
115578...	B10-I: 12, B10-M: 6
115579...	B10-M: 6
115580...	B10-M: 6
115590...	B10-A: 19, B10-A: 58, B10-A: 72, B10-H: 20, B10-H: 21, B10-H: 22, B10-H: 23, B10-H: 24, B10-H: 25, B10-L: 10, B10-M: 6
115591...	B10-A: 19, B10-A: 58, B10-A: 72, B10-H: 16, B10-H: 17, B10-M: 6
115630...	B10-A: 72, B10-M: 6
115641...	B10-M: 4
115643...	B10-I: 33, B10-M: 4
115660...	B10-I: 39
115661...	B10-I: 39
115662...	B10-I: 39
115663...	B10-I: 39
115664...	B10-H: 29, B10-L: 10, B10-M: 6
115666...	B10-D: 23
115667...	B10-D: 23
115669...	B10-G: 22, B10-G: 25
115673...	B10-L: 10
115676...	B10-A: 19, B10-A: 58, B10-A: 72, B10-L: 10
115680...	B10-I: 9
115681...	B10-I: 9
115682...	B10-I: 9
115683...	B10-I: 9
115684...	B10-I: 9
115685...	B10-I: 9
115686...	B10-I: 9
115687...	B10-I: 9
115696...	B10-I: 33
115697...	B10-I: 33
115699...	B10-I: 39
115707...	B10-I: 33
115708...	B10-I: 33
115709...	B10-I: 33
115725...	B10-A: 18
115730...	B10-D: 23
115736...	B10-G: 25
115737...	B10-G: 25
115785...	B10-I: 39
115867...	B10-I: 39
115929...	B10-I: 33
115930...	B10-I: 33
115932...	B10-I: 33
115933...	B10-I: 33
115934...	B10-I: 33
115936...	B10-I: 33

Part No.	Page
115985...	B10-A: 58
116152...	B10-I: 33
116289...	B10-A: 19
116433...	B10-L: 10
116550...	B10-D: 23
117143...	B10-M: 4
117148...	B10-D: 23
119001...	B10-E: 12
119002...	B10-E: 12
119003...	B10-E: 12
119004...	B10-E: 12
119005...	B10-E: 12
119006...	B10-E: 12
119010...	B10-E: 8
119012...	B10-E: 8
119019...	B10-E: 9
119021...	B10-E: 9
119025...	B10-E: 9
119054...	B10-E: 8
119055...	B10-E: 8
119058...	B10-E: 12
119059...	B10-E: 8
119060...	B10-E: 9
119061...	B10-E: 9
119064...	B10-E: 9
119065...	B10-E: 12
119066...	B10-E: 12
119067...	B10-E: 9
119069...	B10-E: 12
119094...	B10-E: 8
119095...	B10-E: 9
119096...	B10-E: 9
119097...	B10-E: 9
119098...	B10-E: 9
126157...	B10-D: 23
130001T003590...	B10-J: 6
130001T003920...	B10-J: 6
130001T004480...	B10-J: 7
130001T004498...	B10-J: 7
130001T004509...	B10-J: 6
130001T007166...	B10-J: 7
130001T016960...	B10-J: 6
130001T016962...	B10-J: 6
130005T003590...	B10-J: 12
130005T003920...	B10-J: 12
130005T004480...	B10-J: 12
130005T004498...	B10-J: 12
130005T016960...	B10-J: 12
130005T016962...	B10-J: 12
132022T003590...	B10-F: 13
132022T003704...	B10-F: 12
132022T003920...	B10-F: 12

Part No.	Page
	B10-F: 13
132022T004480...	B10-F: 11
132022T004498...	B10-F: 11
132022T007166...	B10-F: 13
132022T010229...	B10-F: 12
132022T016960...	B10-F: 6
132022T016962...	B10-F: 6
132066T003704...	B10-F: 12
132066T003920...	B10-F: 13
132066T004480...	B10-F: 11
132066T004498...	B10-F: 11
132066T007166...	B10-F: 13
132066T010229...	B10-F: 12
132066T016960...	B10-F: 6
132066T016962...	B10-F: 6
132076T003704...	B10-F: 12
132076T004480...	B10-F: 11
132076T016962...	B10-F: 6
132088T003704...	B10-F: 12
132088T004480...	B10-F: 11
132088T016962...	B10-F: 6
132142...	B10-M: 3
132143...	B10-M: 3
132144...	B10-M: 3
132145...	B10-M: 3
132146...	B10-M: 3
132191...	B10-M: 2
133113...	B10-M: 3
137019...	B10-B: 33, B10-G: 10, B10-G: 11, B10-G: 20
137026...	B10-B: 30, B10-B: 31, B10-B: 33, B10-G: 10, B10-G: 11, B10-G: 20
137027...	B10-B: 33, B10-G: 10, B10-G: 11, B10-G: 20
140108...	B10-D: 23
140111...	B10-D: 23
140112...	B10-D: 23
140114...	B10-D: 23
140116...	B10-D: 23
140117...	B10-D: 23

Part No.	Page
140118...	B10-B: 33, B10-D: 23, B10-G: 20
140119...	B10-D: 23
140121...	B10-D: 23
143051...	B10-D: 18
143052...	B10-D: 18
143053...	B10-D: 18
143054...	B10-D: 18
143055...	B10-D: 18
143056...	B10-D: 18
143057...	B10-D: 18
143058...	B10-D: 18
145184...	B10-A: 18, B10-A: 19, B10-A: 47, B10-A: 71
148001...	B10-D: 7, B10-D: 9, B10-D: 11, B10-D: 16
148002...	B10-D: 7, B10-D: 9, B10-D: 11, B10-D: 16
148003...	B10-D: 7, B10-D: 9, B10-D: 11, B10-D: 16
148004...	B10-D: 7, B10-D: 9, B10-D: 10, B10-D: 11, B10-D: 14, B10-D: 16
148005...	B10-D: 7, B10-D: 9, B10-D: 10, B10-D: 11, B10-D: 14, B10-D: 17, B10-D: 21
148006...	B10-D: 7, B10-D: 9, B10-D: 10, B10-D: 11, B10-D: 14, B10-D: 17, B10-D: 21
148007...	B10-B: 32, B10-D: 8, B10-D: 9, B10-D: 10, B10-D: 13, B10-D: 17, B10-D: 19, B10-D: 20, B10-D: 21
148009...	B10-B: 32, B10-D: 8, B10-D: 9, B10-D: 10, B10-D: 13, B10-D: 17, B10-D: 19, B10-D: 20, B10-D: 21
148010...	B10-D: 19
148012...	B10-D: 20
148013...	B10-D: 20
148014...	B10-D: 20
148015...	B10-D: 20
148016...	B10-D: 20
148017...	B10-D: 7, B10-D: 9, B10-D: 11, B10-D: 16

A
B
C
D
E
F
G
H
I
J
K
L
M
INDEX

A

Part No.	Page
148018...	B10-D: 7, B10-D: 9, B10-D: 11, B10-D: 16

B

148021...	B10-D: 6, B10-D: 12
148022...	B10-D: 6, B10-D: 12
148023...	B10-D: 6, B10-D: 12

C

148024...	B10-D: 6, B10-D: 12
148110...	B10-D: 23
148113...	B10-D: 23
148114...	B10-D: 23

D

149010...	B10-G: 12
149020...	B10-G: 12
149030...	B10-D: 21
149055...	B10-G: 14
149056...	B10-G: 14
149058...	B10-G: 14

E

149083...	B10-G: 12
149085...	B10-G: 14
149089...	B10-G: 12
149090...	B10-G: 12
149093...	B10-G: 12
149094...	B10-G: 12
149096...	B10-G: 12
149099...	B10-G: 12

F

151001...	B10-D: 6, B10-D: 7, B10-D: 11, B10-D: 12
-----------	--

G

151002...	B10-D: 6, B10-D: 7, B10-D: 11, B10-D: 12
-----------	--

H

151003...	B10-D: 6, B10-D: 7, B10-D: 11, B10-D: 12
151004...	B10-D: 6, B10-D: 7, B10-D: 11, B10-D: 12

I

151005...	B10-D: 7, B10-D: 11
151006...	B10-D: 7, B10-D: 11
151007...	B10-D: 8, B10-D: 13

J

151008...	B10-D: 8, B10-D: 13
151009...	B10-D: 10, B10-D: 14

K

151010...	B10-D: 10, B10-D: 14
151011...	B10-D: 9
151012...	B10-D: 9
151013...	B10-D: 9
151014...	B10-D: 9
151015...	B10-D: 9

L

151019...	B10-D: 21
151022...	B10-D: 10, B10-D: 14
151023...	B10-D: 6, B10-D: 7
151024...	B10-D: 6, B10-D: 7

M

151025...	B10-D: 7
151026...	B10-D: 7
151027...	B10-D: 8
151028...	B10-D: 8
151032...	B10-D: 10, B10-D: 14

Part No.	Page
151034...	B10-D: 14
151035...	B10-D: 10, B10-D: 14

151036...	B10-D: 9
151037...	B10-D: 9
151038...	B10-D: 9
151039...	B10-D: 21
151043...	B10-D: 10, B10-D: 14

151059...	B10-D: 21
151061...	B10-D: 11, B10-D: 12
151062...	B10-D: 11, B10-D: 12

151086...	B10-D: 7, B10-D: 11
151087...	B10-D: 8, B10-D: 13
151088...	B10-D: 8, B10-D: 13
151090...	B10-D: 11
151091...	B10-D: 13
151092...	B10-D: 13
151093...	B10-D: 11, B10-D: 12

151094...	B10-D: 11, B10-D: 12
151095...	B10-D: 11
151096...	B10-D: 11
151097...	B10-D: 13
151098...	B10-D: 13
161002...	B10-I: 5
161003...	B10-I: 5
161004...	B10-I: 5
161005...	B10-I: 5
161006...	B10-I: 5
161016...	B10-I: 4
161024...	B10-I: 2
161026...	B10-I: 2
161027...	B10-I: 2
161028...	B10-I: 2
161038...	B10-I: 36, B10-I: 37
161082...	B10-I: 6
161098...	B10-I: 4
161099...	B10-I: 29
162002...	B10-I: 5
162003...	B10-I: 5
162004...	B10-I: 5
162011...	B10-I: 4
162015...	B10-I: 2
162016...	B10-I: 2
162017...	B10-I: 2
162018...	B10-I: 2
162019...	B10-I: 2
162020...	B10-I: 2
162032...	B10-I: 6
162033...	B10-I: 6
162080...	B10-I: 13
162081...	B10-I: 13
162082...	B10-I: 13
162083...	B10-I: 13
162093...	B10-I: 29
162094...	B10-I: 36, B10-I: 37
162095...	B10-I: 29
166103...	B10-I: 8
166104...	B10-I: 8
166105...	B10-I: 8
201065...	B10-G: 13

Part No.	Page
415164...	B10-M: 6
2	
201003...	B10-D: 16
201004...	B10-D: 16
201007...	B10-D: 16
201008...	B10-D: 16
201009...	B10-D: 16
201010...	B10-D: 17
201011...	B10-D: 17
201012...	B10-D: 17
201013...	B10-D: 17
201015...	B10-G: 13
201017...	B10-D: 16
201018...	B10-D: 16
201019...	B10-D: 16
201020...	B10-D: 16
201021...	B10-D: 17
201022...	B10-D: 17
201023...	B10-D: 17
201024...	B10-D: 17
201025...	B10-G: 13
201057...	B10-D: 16
201058...	B10-D: 16
201059...	B10-D: 16
201061...	B10-D: 17
201062...	B10-D: 17
201063...	B10-D: 17
201064...	B10-D: 17
201067...	B10-D: 16
201068...	B10-D: 16
201069...	B10-D: 16
201070...	B10-D: 16
201071...	B10-D: 17
201073...	B10-D: 17
201074...	B10-D: 17
201075...	B10-G: 13
201077...	B10-D: 16
201082...	B10-D: 15
201083...	B10-D: 15
201087...	B10-D: 15
201088...	B10-D: 15
201089...	B10-D: 15
209022...	B10-I: 33
209023...	B10-I: 33
209024...	B10-I: 33
209025...	B10-I: 33
209026...	B10-I: 33
209027...	B10-I: 33
209028...	B10-I: 33
209043...	B10-G: 15
209044...	B10-I: 7
209045...	B10-I: 7
209054...	B10-I: 13
209055...	B10-I: 13
209056...	B10-I: 13
209057...	B10-I: 13
209058...	B10-I: 13
209059...	B10-I: 13
209060...	B10-G: 15
209080...	B10-I: 6
209081...	B10-I: 6
209082...	B10-I: 4
209083...	B10-I: 4
209088...	B10-I: 3
209089...	B10-I: 3
209090...	B10-I: 3
209091...	B10-I: 3
209098...	B10-I: 7

Part No.	Page
209099...	B10-I: 7
210020...	B10-B: 6, B10-B: 19, B10-B: 24, B10-B: 25, B10-B: 30, B10-B: 31, B10-G: 10, B10-G: 11
210052...	B10-B: 12, B10-B: 18, B10-B: 24
210059...	B10-B: 12, B10-B: 24
210062...	B10-B: 12, B10-B: 18, B10-B: 24
210063...	B10-B: 6, B10-B: 19, B10-B: 24, B10-B: 25, B10-B: 30, B10-B: 31, B10-G: 10, B10-G: 11
210064...	B10-B: 6, B10-B: 19, B10-B: 24, B10-B: 25, B10-B: 30, B10-B: 31, B10-G: 10, B10-G: 11
210069...	B10-B: 12, B10-B: 24
211061...	B10-B: 7, B10-B: 14, B10-B: 20, B10-B: 26, B10-B: 32, B10-G: 20
211063...	B10-B: 7, B10-B: 14, B10-B: 20, B10-B: 26, B10-B: 32, B10-G: 20
214462...	B10-B: 27
215101...	B10-B: 33, B10-G: 20
215102...	B10-B: 33, B10-G: 20
215105...	B10-B: 33, B10-G: 20
215111...	B10-D: 23
215149...	B10-L: 10
215150...	B10-A: 58, B10-A: 72, B10-H: 29, B10-L: 10, B10-M: 6
215189...	B10-M: 4

Part No.	Page
215250...	B10-L: 10
215254...	B10-A: 47, B10-A: 71
215265...	B10-L: 10
215323...	B10-B: 15, B10-B: 27
215338...	B10-B: 15, B10-B: 21, B10-B: 27
215343...	B10-L: 10
215346...	B10-D: 23
215374...	B10-D: 23
215375...	B10-M: 3
215376...	B10-M: 3
215377...	B10-A: 19, B10-L: 10
215431...	B10-L: 10
215461...	B10-L: 10
215462...	B10-B: 15, B10-B: 21, B10-B: 27, B10-B: 33
215467...	B10-L: 10
215472...	B10-A: 19, B10-A: 72, B10-L: 10, B10-M: 6
215473...	B10-A: 58, B10-L: 10, B10-M: 6
215483...	B10-A: 18, B10-B: 8, B10-B: 33, B10-G: 21
215501...	B10-C: 7
215509...	B10-G: 25
215608...	B10-I: 33
215609...	B10-I: 33
215610...	B10-I: 33
215611...	B10-I: 33
215612...	B10-I: 33
215634...	B10-L: 10
215638...	B10-M: 6
215639...	B10-M: 6
215674...	B10-A: 19, B10-A: 72
215701...	B10-I: 33
215702...	B10-I: 33
215703...	B10-I: 33
215704...	B10-I: 33
215705...	B10-I: 33
215726...	B10-F: 14
215727...	B10-F: 14
215728...	B10-F: 14
215742...	B10-L: 10
215922...	B10-I: 30
215924...	B10-I: 30
215925...	B10-I: 30
215926...	B10-F: 14, B10-I: 30
215927...	B10-I: 39
215929...	B10-I: 39
215930...	B10-I: 39
215931...	B10-F: 15, B10-I: 39
218012...	B10-A: 8
218014...	B10-A: 8
218029...	B10-A: 9

Part No.	Page
	B10-A: 41
218030...	B10-A: 9, B10-A: 41
218031...	B10-A: 9, B10-A: 41
218032...	B10-A: 9, B10-A: 41
218033...	B10-A: 9, B10-A: 41
218034...	B10-A: 9, B10-A: 41
218037...	B10-A: 9, B10-A: 41
218038...	B10-A: 9, B10-A: 41
218039...	B10-A: 9, B10-A: 41
218040...	B10-A: 9, B10-A: 41
218041...	B10-A: 9, B10-A: 41
218042...	B10-A: 9, B10-A: 41
218043...	B10-A: 9, B10-A: 41
218044...	B10-A: 9, B10-A: 41
218045...	B10-A: 9, B10-A: 41
218046...	B10-A: 9, B10-A: 41
218047...	B10-A: 8
218048...	B10-A: 8
218049...	B10-A: 8
218050...	B10-A: 8
218051...	B10-A: 8
218052...	B10-A: 8
218053...	B10-A: 8
218058...	B10-A: 8
218059...	B10-A: 8
218060...	B10-A: 8
218061...	B10-A: 8
218062...	B10-A: 8
218063...	B10-A: 8
218064...	B10-A: 8
218071...	B10-A: 8
218072...	B10-A: 9, B10-A: 40
218074...	B10-A: 32
218075...	B10-A: 32
218076...	B10-A: 32
218077...	B10-A: 32
218079...	B10-A: 32
218080...	B10-A: 32
218081...	B10-A: 32
218082...	B10-A: 32
218083...	B10-A: 32
218084...	B10-A: 32
218088...	B10-J: 4
218089...	B10-J: 8, B10-J: 10
219030...	B10-E: 8
219031...	B10-E: 9
219032...	B10-E: 8
219033...	B10-E: 9
219034...	B10-E: 8
219035...	B10-E: 8
219036...	B10-E: 8
219037...	B10-E: 8

Part No.	Page
219038...	B10-E: 8
219039...	B10-E: 8
219040...	B10-E: 8
219041...	B10-E: 8
219042...	B10-E: 9
219043...	B10-E: 12
219044...	B10-E: 12
219051...	B10-E: 8
219052...	B10-E: 8
219053...	B10-E: 9
219054...	B10-E: 9
219055...	B10-E: 11
219056...	B10-E: 11
219057...	B10-E: 11
219058...	B10-E: 11
219059...	B10-E: 11
219060...	B10-E: 11
219061...	B10-E: 12
219062...	B10-E: 12
219063...	B10-E: 12
219066...	B10-E: 9
219068...	B10-E: 12
219076...	B10-I: 11
219077...	B10-I: 11
219082...	B10-E: 12
219083...	B10-E: 12
219084...	B10-E: 12
219085...	B10-E: 8
219086...	B10-E: 8
219087...	B10-E: 8
219088...	B10-E: 8
219089...	B10-E: 9
219090...	B10-E: 9
219091...	B10-E: 9
219092...	B10-E: 9
219093...	B10-E: 11
219094...	B10-E: 12
219095...	B10-E: 12
219096...	B10-E: 12
219168...	B10-A: 33, B10-E: 6
219169...	B10-A: 33, B10-E: 6
219170...	B10-I: 11
219171...	B10-I: 11
219172...	B10-I: 11
219173...	B10-I: 11
219174...	B10-I: 11
219175...	B10-I: 11
219176...	B10-A: 33, B10-E: 6
219177...	B10-A: 33, B10-E: 6
219185...	B10-A: 33, B10-E: 6
226011...	B10-D: 19
226012...	B10-D: 19
226013...	B10-D: 19
226014...	B10-G: 14
226030...	B10-D: 19
226031...	B10-D: 19, B10-G: 14
227001...	B10-F: 5
227002...	B10-F: 5
227003...	B10-F: 5
227004...	B10-F: 5
227005...	B10-F: 5
227006...	B10-F: 5
227007...	B10-F: 5
227008...	B10-F: 5
227009...	B10-F: 5
227010...	B10-F: 5
227011...	B10-F: 5

Part No.	Page
227012...	B10-F: 5
227014...	B10-F: 5
228003...	B10-I: 4
228004...	B10-I: 4
228006...	B10-I: 4
228007...	B10-I: 4
228014...	B10-I: 2
228020...	B10-I: 4
228021...	B10-I: 4
228022...	B10-I: 2
228023...	B10-I: 2
228024...	B10-I: 2
228025...	B10-I: 2
228026...	B10-I: 2
231005...	B10-I: 7
231006...	B10-I: 7
231007...	B10-I: 7
233001...	B10-I: 36
233002...	B10-I: 36
233003...	B10-I: 36
233004...	B10-I: 36
233005...	B10-I: 36
233006...	B10-I: 36
233007...	B10-I: 36
233008...	B10-I: 36
233009...	B10-I: 36
233020...	B10-I: 37
233021...	B10-I: 37
233022...	B10-I: 37
233023...	B10-I: 37
233024...	B10-I: 37
233025...	B10-I: 37
233026...	B10-I: 37
233027...	B10-I: 37
233028...	B10-I: 37
233040...	B10-I: 38
233041...	B10-I: 38
233042...	B10-I: 38
233043...	B10-I: 38
233044...	B10-I: 38
233045...	B10-I: 38
233046...	B10-I: 38
233047...	B10-I: 38
233048...	B10-I: 38
233070...	B10-I: 35
233071...	B10-I: 35
233072...	B10-I: 35
233073...	B10-I: 35
233074...	B10-I: 35
233075...	B10-I: 35
233076...	B10-I: 35
235001...	B10-D: 5
235002...	B10-D: 5
235003...	B10-D: 5
235011...	B10-D: 5
235012...	B10-D: 5
235013...	B10-D: 5
235021...	B10-D: 5
235022...	B10-D: 5
235023...	B10-D: 5
235031...	B10-D: 5
235032...	B10-D: 5
235033...	B10-D: 5
236020...	B10-A: 14, B10-A: 18
236021...	B10-A: 12
236022...	B10-A: 12
236023...	B10-A: 12

Part No.	Page
236024...	B10-A: 12
236025...	B10-A: 12
236031...	B10-A: 12
236071...	B10-A: 7, B10-A: 39
236081...	B10-A: 15, B10-A: 45, B10-A: 69
236082...	B10-A: 15, B10-A: 45, B10-A: 69
236083...	B10-A: 15, B10-A: 45, B10-A: 69
236084...	B10-A: 15, B10-A: 45, B10-A: 69
236088...	B10-A: 15, B10-A: 18, B10-A: 45, B10-A: 47
236089...	B10-A: 15, B10-A: 18, B10-A: 45, B10-A: 47
236120...	B10-A: 18, B10-A: 47
245011...	B10-F: 4
245012...	B10-F: 4
245013...	B10-F: 4
245014...	B10-F: 4
245015...	B10-F: 4
245016...	B10-F: 4
246004...	B10-F: 4
246009...	B10-F: 4
246010...	B10-F: 4
246012...	B10-F: 4
246013...	B10-F: 4
246014...	B10-F: 4
246015...	B10-F: 4
246016...	B10-F: 4
246017...	B10-F: 4
246018...	B10-F: 4
246019...	B10-F: 4
246020...	B10-F: 4
246021...	B10-F: 4
246022...	B10-F: 4
246023...	B10-F: 4
248001...	B10-A: 30
248002...	B10-A: 30
248003...	B10-A: 30
248051...	B10-A: 30
248052...	B10-A: 30
248053...	B10-A: 30
248054...	B10-A: 30
248055...	B10-A: 30
248056...	B10-A: 30
248063...	B10-A: 32
248064...	B10-A: 32
248065...	B10-A: 32
248071...	B10-A: 31
248136...	B10-A: 34, B10-F: 2
248137...	B10-A: 34, B10-F: 2
248138...	B10-A: 34, B10-F: 2
248142...	B10-A: 34, B10-F: 2
248143...	B10-A: 34, B10-F: 2
248144...	B10-A: 34, B10-F: 2
248145...	B10-A: 34, B10-F: 2

Part No.	Page
248147...	B10-A: 33, B10-E: 7
248148...	B10-A: 33, B10-E: 7
248149...	B10-A: 33, B10-E: 7
251001...	B10-D: 20
251002...	B10-D: 20
251003...	B10-D: 20
251004...	B10-D: 20
251005...	B10-D: 20
251006...	B10-D: 20
251007...	B10-D: 20
251008...	B10-D: 20
251009...	B10-D: 20
251010...	B10-G: 13
251011...	B10-G: 13
252090...	B10-F: 4
252091...	B10-F: 4
258021...	B10-G: 16
258061...	B10-G: 16
258098...	B10-G: 16
259080...	B10-F: 8
259081...	B10-F: 10
259082...	B10-F: 10
259084...	B10-F: 12
262002...	B10-F: 14
262003...	B10-F: 14
262004...	B10-F: 14
262005...	B10-F: 14
262006...	B10-F: 14
262007...	B10-F: 14
264051...	B10-B: 12
264077...	B10-B: 12
268009...	B10-D: 14
268010...	B10-D: 14
268019...	B10-D: 14
268020...	B10-D: 14
268021...	B10-D: 14
268022...	B10-D: 14
268023...	B10-D: 14
271004...	B10-I: 34
271005...	B10-I: 34
271008...	B10-I: 34
271018...	B10-I: 34
271045...	B10-I: 34
271046...	B10-I: 34
271047...	B10-I: 34
271049...	B10-I: 34
271050...	B10-I: 34
271051...	B10-I: 34
271052...	B10-I: 34
271070...	B10-I: 34
271073...	B10-I: 34
271074...	B10-I: 34
271075...	B10-I: 34
271075...	B10-I: 34
271190...	B10-I: 10
271191...	B10-I: 10
271192...	B10-I: 10
271193...	B10-I: 10
271194...	B10-I: 10
271195...	B10-I: 10
271196...	B10-I: 10
271197...	B10-I: 10
271198...	B10-I: 10
271199...	B10-I: 10
271200...	B10-I: 10
271201...	B10-I: 10
271202...	B10-I: 10
271203...	B10-I: 10
271204...	B10-I: 10

A

B

C

D

E

F

G

H

I

J

K

L

M

INDEX

Part No.	Page
271205...	B10-I: 10
271206...	B10-I: 10
271207...	B10-I: 10
271208...	B10-I: 10
271209...	B10-I: 10
271210...	B10-I: 10
271211...	B10-I: 10
275001...	B10-I: 29
275003...	B10-I: 29
275014...	B10-I: 31
275015...	B10-I: 31
275016...	B10-I: 31
275017...	B10-I: 31
275018...	B10-I: 31
275019...	B10-I: 31
275020...	B10-I: 31
275021...	B10-I: 31
275022...	B10-I: 31
275023...	B10-I: 31
275024...	B10-I: 31
275025...	B10-I: 31
275026...	B10-I: 31
275027...	B10-I: 31
275028...	B10-I: 31
275029...	B10-I: 31
275030...	B10-I: 31
275031...	B10-I: 31
275032...	B10-I: 31
275033...	B10-I: 31
275034...	B10-I: 31
275035...	B10-I: 31
275036...	B10-I: 31
275040...	B10-I: 31
275041...	B10-I: 31
275042...	B10-I: 31
275043...	B10-I: 31
275044...	B10-I: 31
275045...	B10-I: 31
275046...	B10-I: 31
275047...	B10-I: 31
275048...	B10-I: 31
275049...	B10-I: 31
275050...	B10-I: 31
275051...	B10-I: 31
275052...	B10-I: 31
275053...	B10-I: 31
275054...	B10-I: 31
275055...	B10-I: 31
275056...	B10-I: 31
275057...	B10-I: 31
275058...	B10-I: 31
275059...	B10-I: 31
275060...	B10-I: 31
275061...	B10-I: 31
275062...	B10-I: 31
275063...	B10-I: 31
275064...	B10-I: 31
275065...	B10-I: 31
275066...	B10-I: 31
275067...	B10-I: 31
275068...	B10-I: 31
275069...	B10-I: 31
275070...	B10-I: 31
275071...	B10-I: 31
275072...	B10-I: 31
275073...	B10-I: 31
275074...	B10-I: 31
275075...	B10-I: 31

Part No.	Page
275076...	B10-I: 31
275077...	B10-I: 31
275078...	B10-I: 31
275079...	B10-I: 31
275080...	B10-I: 31
275081...	B10-I: 31
275082...	B10-I: 31
275083...	B10-I: 31
275084...	B10-I: 31
276001...	B10-I: 29
276005...	B10-I: 31
276006...	B10-I: 31
276007...	B10-I: 31
276008...	B10-I: 31
276009...	B10-I: 31
276010...	B10-I: 31
276011...	B10-I: 31
276012...	B10-I: 31
276013...	B10-I: 31
276014...	B10-I: 31
276015...	B10-I: 31
276016...	B10-I: 31
276017...	B10-I: 31
276018...	B10-I: 31
276019...	B10-I: 31
276020...	B10-I: 31
276021...	B10-I: 31
276022...	B10-I: 31
276023...	B10-I: 31
276024...	B10-I: 31
276025...	B10-I: 31
276026...	B10-I: 31
276027...	B10-I: 31
276028...	B10-I: 31
276029...	B10-I: 31
276030...	B10-I: 31
276031...	B10-I: 31
276032...	B10-I: 31
276033...	B10-I: 31
276034...	B10-I: 31
276035...	B10-I: 31
276036...	B10-I: 31
276037...	B10-I: 31
276038...	B10-I: 31
276039...	B10-I: 31
276040...	B10-I: 31
276041...	B10-I: 31
276042...	B10-I: 31
276043...	B10-I: 31
276044...	B10-I: 31
276045...	B10-I: 31
276046...	B10-I: 31
276047...	B10-I: 31
276048...	B10-I: 31
276049...	B10-I: 31
276050...	B10-I: 31
276051...	B10-I: 31
276052...	B10-I: 31
276053...	B10-I: 31
276054...	B10-I: 31
276055...	B10-I: 31
276056...	B10-I: 31
276057...	B10-I: 31
276059...	B10-I: 31
276060...	B10-I: 31
276061...	B10-I: 31
277001...	B10-I: 30
277002...	B10-I: 30

Part No.	Page
277005...	B10-I: 30
277006...	B10-I: 30
277007...	B10-I: 30
277008...	B10-I: 30
277010...	B10-I: 32
277011...	B10-I: 32
277012...	B10-I: 32
277013...	B10-I: 32
277014...	B10-I: 32
277015...	B10-I: 32
277016...	B10-I: 32
277017...	B10-I: 32
277018...	B10-I: 32
277019...	B10-I: 32
277020...	B10-I: 32
277021...	B10-I: 32
277022...	B10-I: 32
277023...	B10-I: 32
277024...	B10-I: 32
277025...	B10-I: 32
277026...	B10-I: 32
277027...	B10-I: 32
277028...	B10-I: 32
277029...	B10-I: 32
277030...	B10-I: 32
277031...	B10-I: 32
277032...	B10-I: 32
277033...	B10-I: 32
277034...	B10-I: 32
277035...	B10-I: 32
277036...	B10-I: 32
277037...	B10-I: 32
277038...	B10-I: 32
277039...	B10-I: 32
277040...	B10-I: 32
277041...	B10-I: 32
277042...	B10-I: 32
277043...	B10-I: 32
277044...	B10-I: 32
277045...	B10-I: 32
277046...	B10-I: 32
277047...	B10-I: 32
277048...	B10-I: 32
277049...	B10-I: 32
277050...	B10-I: 32
277051...	B10-I: 32
277055...	B10-I: 32
277056...	B10-I: 32
277057...	B10-I: 32
277058...	B10-I: 32
277059...	B10-I: 32
277060...	B10-I: 32
277061...	B10-I: 32
277062...	B10-I: 32
277063...	B10-I: 32
277064...	B10-I: 32
277065...	B10-I: 32
277066...	B10-I: 32
277067...	B10-I: 32
277068...	B10-I: 32
277069...	B10-I: 32
277070...	B10-I: 32
277071...	B10-I: 32
277072...	B10-I: 32
277073...	B10-I: 32
277074...	B10-I: 32
277075...	B10-I: 32
277076...	B10-I: 32

Part No.	Page
277077...	B10-I: 32
277078...	B10-I: 32
277079...	B10-I: 32
277080...	B10-I: 32
277081...	B10-I: 32
277082...	B10-I: 32
277083...	B10-I: 32
277084...	B10-I: 32
277085...	B10-I: 32
277086...	B10-I: 32
277087...	B10-I: 32
277088...	B10-I: 32
277089...	B10-I: 32
278001...	B10-F: 14, B10-I: 30
278002...	B10-I: 30
278005...	B10-I: 32
278006...	B10-I: 32
278007...	B10-I: 32
278008...	B10-I: 32
278009...	B10-I: 32
278010...	B10-I: 32
278011...	B10-I: 32
278012...	B10-I: 32
278013...	B10-I: 32
278014...	B10-I: 32
278015...	B10-I: 32
278016...	B10-I: 32
278017...	B10-I: 32
278018...	B10-I: 32
278019...	B10-I: 32
278020...	B10-I: 32
278021...	B10-I: 32
278022...	B10-I: 32
278023...	B10-I: 32
278024...	B10-I: 32
278025...	B10-I: 32
278026...	B10-I: 32
278027...	B10-I: 32
278028...	B10-I: 32
278029...	B10-F: 15, B10-I: 32
278030...	B10-I: 32
278031...	B10-I: 32
278032...	B10-I: 32
278033...	B10-I: 32
278034...	B10-I: 32
278035...	B10-F: 15, B10-I: 32
278036...	B10-I: 32
278037...	B10-I: 32
278038...	B10-I: 32
278039...	B10-F: 15, B10-I: 32
278040...	B10-I: 32
278041...	B10-I: 32
278042...	B10-I: 32
278043...	B10-I: 32
278044...	B10-I: 32
278045...	B10-F: 15, B10-I: 32
278046...	B10-I: 32
278047...	B10-I: 32
278048...	B10-I: 32
278049...	B10-I: 32
278050...	B10-I: 32
278051...	B10-I: 32
297164...	B10-H: 24

Part No.	Page
297165...	B10-H: 24
297192...	B10-H: 24
297234...	B10-H: 24
297239...	B10-H: 22
297240...	B10-H: 22
297241...	B10-H: 22
297242...	B10-H: 22
297248...	B10-H: 22
297249...	B10-H: 24
297259...	B10-H: 17
297260...	B10-H: 17
297262...	B10-H: 17
297264...	B10-H: 17
297290...	B10-H: 25
297291...	B10-H: 25
297293...	B10-H: 25
297294...	B10-H: 25
297303...	B10-H: 25
297306...	B10-H: 25
297377...	B10-H: 22
297387...	B10-H: 20
297419...	B10-H: 25
297434...	B10-H: 20
297473...	B10-H: 16
297483...	B10-H: 24
297485...	B10-H: 20
297486...	B10-H: 25
297497...	B10-H: 28
297501...	B10-H: 24
297502...	B10-H: 24
297531...	B10-H: 22
297533...	B10-H: 24
297534...	B10-H: 20
297535...	B10-H: 28
297537...	B10-H: 20
297541...	B10-H: 16
297542...	B10-H: 16
297545...	B10-H: 21
297546...	B10-H: 21
297547...	B10-H: 21
297548...	B10-H: 21
297550...	B10-H: 20
297557...	B10-H: 20
297558...	B10-H: 20
297559...	B10-H: 22
297560...	B10-H: 22
297561...	B10-H: 24
297578...	B10-H: 24
297588...	B10-H: 22
297604...	B10-H: 18
297653...	B10-H: 22
297658...	B10-H: 22
297659...	B10-H: 25
297660...	B10-H: 25
297692...	B10-H: 17
297721...	B10-H: 26
297724...	B10-H: 20
297725...	B10-H: 20
297780...	B10-H: 17
297782...	B10-H: 17
297787...	B10-H: 25
297788...	B10-H: 25
297790...	B10-H: 25
297833...	B10-H: 20
297845...	B10-H: 17
297870...	B10-H: 24
297871...	B10-H: 24
297872...	B10-H: 24

Part No.	Page
297878...	B10-H: 22
297891...	B10-H: 20
297937...	B10-H: 31
297938...	B10-H: 31
297939...	B10-H: 31
297940...	B10-H: 31
297941...	B10-H: 31
297942...	B10-H: 31
297943...	B10-H: 31
297944...	B10-H: 31
297945...	B10-H: 31
297946...	B10-H: 31
297947...	B10-H: 31
297958...	B10-H: 22
297980...	B10-H: 21
297993...	B10-H: 18
297994...	B10-H: 21
297995...	B10-H: 21
297996...	B10-H: 28
297997...	B10-H: 28
299001...	B10-F: 3
299002...	B10-F: 3
299003...	B10-F: 3
299004...	B10-F: 3
299005...	B10-F: 3
299006...	B10-F: 3
299007...	B10-F: 3
299008...	B10-F: 3
299009...	B10-F: 3
3	
259079...	B10-F: 8
309001...	B10-G: 15
309041...	B10-G: 15
309043...	B10-G: 15
310001...	B10-B: 24
310003...	B10-B: 24
310004...	B10-B: 24
310005...	B10-B: 24
310006...	B10-B: 24
310007...	B10-B: 25
310008...	B10-B: 25
310009...	B10-B: 25
310010...	B10-B: 24
310020...	B10-B: 24
310070...	B10-B: 26
310071...	B10-B: 26
310074...	B10-B: 26
310075...	B10-B: 26
315015...	B10-I: 30
315016...	B10-I: 30
315017...	B10-I: 30
315018...	B10-I: 30
315155...	B10-A: 18, B10-A: 47, B10-A: 71
315156...	B10-A: 18, B10-A: 47, B10-A: 71
315186...	B10-G: 22, B10-G: 25, B10-M: 4
315234...	B10-F: 14
315235...	B10-F: 14
315248...	B10-A: 19, B10-A: 71
315265...	B10-M: 6
315279...	B10-B: 27
315320...	B10-H: 35

Part No.	Page
315322...	B10-H: 35, B10-M: 6
315323...	B10-H: 19
315355...	B10-G: 14
315403...	B10-G: 25
315415...	B10-G: 25
315476...	B10-L: 10
315629...	B10-A: 35
315637...	B10-I: 39
315684...	B10-A: 35
315687...	B10-A: 35
315689...	B10-I: 39, B10-M: 6
315690...	B10-M: 6
315691...	B10-I: 39, B10-M: 6
315788...	B10-I: 9
315789...	B10-I: 9
315790...	B10-I: 9
315801...	B10-A: 35
315943...	B10-B: 15, B10-B: 21
319002...	B10-E: 13
319003...	B10-E: 13
319004...	B10-E: 13
319005...	B10-E: 13
319006...	B10-E: 13
319007...	B10-E: 13
319008...	B10-E: 13
319009...	B10-E: 13
319010...	B10-A: 7, B10-A: 39
319013...	B10-E: 10
319016...	B10-E: 13
319017...	B10-E: 13
319018...	B10-E: 13
319019...	B10-E: 13
319021...	B10-E: 13
319022...	B10-E: 13
319023...	B10-E: 13
326062...	B10-G: 18
326082...	B10-G: 18
326083...	B10-G: 17
326084...	B10-G: 18
327001...	B10-F: 8
327002...	B10-F: 8
327003...	B10-F: 8
327004...	B10-F: 8
327005...	B10-F: 8
327006...	B10-F: 8
327007...	B10-F: 8
327010...	B10-F: 8
327011...	B10-F: 8
327012...	B10-F: 10
327013...	B10-F: 10
327016...	B10-F: 10
327017...	B10-F: 8
327018...	B10-F: 8
327019...	B10-F: 10
327020...	B10-F: 10
327021...	B10-F: 10
327022...	B10-F: 10
327023...	B10-F: 10
327024...	B10-F: 10
327025...	B10-F: 8
327026...	B10-F: 8
327027...	B10-F: 8
327028...	B10-F: 8
327033...	B10-F: 8
327034...	B10-F: 8

Part No.	Page
337105...	B10-B: 33, B10-G: 20
345001...	B10-L: 6
345002...	B10-L: 6
345003...	B10-L: 6
345004...	B10-L: 6
345005...	B10-L: 6
345006...	B10-L: 6
345007...	B10-L: 6
345008...	B10-L: 6
345009...	B10-L: 6
345010...	B10-L: 6
345011...	B10-L: 6
345012...	B10-L: 6
345013...	B10-L: 6
345014...	B10-L: 6
345015...	B10-L: 7
345016...	B10-L: 7
345017...	B10-L: 7
345018...	B10-L: 7
345019...	B10-L: 7
345020...	B10-L: 8
345021...	B10-L: 8
345022...	B10-L: 8
345023...	B10-L: 8
345024...	B10-L: 8
345025...	B10-L: 8
345030...	B10-L: 2
345031...	B10-L: 2
345032...	B10-L: 2
345033...	B10-L: 2
345034...	B10-L: 3
345035...	B10-L: 3
345036...	B10-L: 3
345037...	B10-L: 3
345040...	B10-L: 2
345041...	B10-L: 2
345042...	B10-L: 2
345043...	B10-L: 2
345044...	B10-L: 3
345045...	B10-L: 3
345046...	B10-L: 3
345047...	B10-L: 3
345201...	B10-L: 10
345202...	B10-L: 10
345203...	B10-L: 10
345204...	B10-L: 10
345208...	B10-L: 10
345211...	B10-L: 10
345213...	B10-L: 10
345215...	B10-L: 10
345216...	B10-L: 10
345218...	B10-L: 10
345220...	B10-L: 10
345221...	B10-L: 10
345222...	B10-L: 10
345223...	B10-L: 10
345224...	B10-L: 10
345225...	B10-L: 10
348007...	B10-D: 14
348009...	B10-D: 19
349005...	B10-G: 6
349006...	B10-G: 6
349009...	B10-D: 14
349010...	B10-G: 22
349011...	B10-G: 22
349012...	B10-G: 22
349013...	B10-G: 22

Part No.	Page
349014...	B10-G: 6
349015...	B10-G: 6
349016...	B10-G: 23
349017...	B10-G: 23
349021...	B10-G: 4
349022...	B10-G: 4
349023...	B10-G: 4
349024...	B10-G: 4
349031...	B10-G: 7
349032...	B10-G: 7
349033...	B10-G: 7
349034...	B10-G: 7
349035...	B10-G: 7
349036...	B10-G: 7
349037...	B10-G: 7
349038...	B10-G: 7
349043...	B10-G: 25
349051...	B10-G: 5
349052...	B10-G: 5
349053...	B10-G: 5
349054...	B10-G: 5
349201...	B10-G: 25
349202...	B10-G: 25
353064...	B10-F: 7
353065...	B10-F: 7
353066...	B10-F: 7
353067...	B10-F: 7
353068...	B10-F: 7
353069...	B10-F: 7
353070...	B10-F: 9
353071...	B10-F: 9
353072...	B10-F: 9
353073...	B10-F: 9
353074...	B10-F: 9
353075...	B10-F: 9
358015...	B10-G: 16
364030...	B10-B: 12
364031...	B10-B: 12
364077...	B10-B: 12, B10-B: 24
364138...	B10-B: 15, B10-B: 27
364139...	B10-B: 15, B10-B: 27
364260...	B10-B: 15, B10-B: 27
364270...	B10-B: 15, B10-B: 27
387112...	B10-I: 12
387113...	B10-I: 12
387114...	B10-I: 12
387115...	B10-I: 12
387116...	B10-I: 12
397110...	B10-H: 28
397118...	B10-H: 20
397133...	B10-H: 17
397146...	B10-H: 17
397164...	B10-H: 23
397165...	B10-H: 23
397166...	B10-H: 23
397167...	B10-H: 23
397168...	B10-H: 23
397191...	B10-H: 23
397192...	B10-H: 17
397235...	B10-H: 26
397237...	B10-H: 15
397244...	B10-H: 24
397251...	B10-H: 24

Part No.	Page
397252...	B10-H: 24
397257...	B10-H: 24
397260...	B10-H: 25
397261...	B10-H: 25
397270...	B10-H: 27
397271...	B10-H: 27
397272...	B10-H: 27
397273...	B10-H: 27
397274...	B10-H: 27
397301...	B10-H: 17
397352...	B10-H: 20
397354...	B10-H: 20
397355...	B10-H: 20
397356...	B10-H: 20
397357...	B10-H: 20
397439...	B10-H: 25
397585...	B10-H: 23
397586...	B10-H: 23
397587...	B10-H: 23
397588...	B10-H: 23
397589...	B10-H: 23
397590...	B10-H: 28
397593...	B10-H: 29
397594...	B10-H: 29
397595...	B10-H: 29
397610...	B10-H: 17
397614...	B10-H: 22
397632...	B10-H: 22
397640...	B10-H: 28
397654...	B10-H: 18
397662...	B10-H: 21
397663...	B10-H: 18
397666...	B10-H: 22
397672...	B10-H: 16
397673...	B10-H: 16
397674...	B10-H: 16
397675...	B10-H: 14
397676...	B10-H: 14
397688...	B10-H: 16
397689...	B10-H: 16
397702...	B10-H: 23
397703...	B10-H: 28
397704...	B10-H: 28
397705...	B10-H: 28
397709...	B10-H: 28
397710...	B10-H: 28
397737...	B10-H: 21
397738...	B10-H: 21
397739...	B10-H: 21
397740...	B10-H: 21
397741...	B10-H: 28
397742...	B10-H: 21
397763...	B10-H: 15
397764...	B10-H: 16
397765...	B10-H: 20
397766...	B10-H: 22
397767...	B10-H: 22
397768...	B10-H: 22
397769...	B10-H: 18
397770...	B10-H: 18
397771...	B10-H: 18
397772...	B10-H: 18
397783...	B10-H: 26
397784...	B10-H: 26
397785...	B10-H: 26
397786...	B10-H: 26
397787...	B10-H: 26
397788...	B10-H: 26

A

Part No.	Page
397809...	B10-H: 26
397810...	B10-H: 26
397816...	B10-H: 26
397817...	B10-H: 26
397844...	B10-H: 29
397916...	B10-H: 16
397917...	B10-H: 16

B

Part No.	Page
401003...	B10-C: 5, B10-C: 7
401004...	B10-C: 5, B10-C: 7
401005...	B10-C: 5, B10-C: 7
401006...	B10-C: 5, B10-C: 7
401007...	B10-C: 5, B10-C: 7
401008...	B10-C: 5, B10-C: 7
401009...	B10-C: 5, B10-C: 7
401010...	B10-C: 5, B10-C: 7
401011...	B10-C: 5, B10-C: 7

C

Part No.	Page
401204...	B10-C: 7
401205...	B10-C: 7
401206...	B10-C: 7
401207...	B10-C: 7
401208...	B10-C: 7
401209...	B10-C: 7
401210...	B10-C: 7
401223...	B10-C: 7
401224...	B10-C: 7

D

Part No.	Page
401225...	B10-C: 7
401226...	B10-C: 7
401227...	B10-C: 7
401230...	B10-C: 7
401323...	B10-C: 7
401324...	B10-C: 7
401327...	B10-C: 7
401329...	B10-C: 7
402001...	B10-C: 5

E

Part No.	Page
402005...	B10-C: 5
402011...	B10-C: 5
402013...	B10-C: 5
402017...	B10-C: 5
402019...	B10-C: 5
402021...	B10-C: 5
402025...	B10-C: 5
402026...	B10-C: 5
402029...	B10-C: 5

F

Part No.	Page
410001...	B10-B: 4
410002...	B10-B: 4
415111...	B10-D: 23
415112...	B10-A: 19, B10-A: 71, B10-D: 23
415113...	B10-D: 23

G

Part No.	Page
415121...	B10-M: 6
415127...	B10-F: 14
415164...	B10-L: 10
415165...	B10-L: 10, B10-M: 6
415181...	B10-G: 25

H

Part No.	Page
415244...	B10-A: 18, B10-A: 35, B10-A: 47, B10-A: 71
415280...	B10-L: 10
415283...	B10-M: 5
415284...	B10-M: 5
415285...	B10-M: 5
415286...	B10-M: 5
415287...	B10-M: 5
415298...	B10-L: 10

I

Part No.	Page
415511...	B10-H: 21, B10-H: 22, B10-H: 23, B10-M: 6
415514...	B10-A: 19, B10-A: 58, B10-A: 72, B10-H: 20, B10-H: 21, B10-H: 22, B10-H: 23, B10-H: 24, B10-H: 25, B10-M: 6
415543...	B10-H: 20, B10-H: 21, B10-H: 22, B10-H: 23, B10-H: 29, B10-M: 6
415573...	B10-M: 5
415577...	B10-A: 58, B10-I: 12, B10-L: 10, B10-M: 6

J

Part No.	Page
415578...	B10-A: 58, B10-M: 6
415579...	B10-M: 6
415580...	B10-M: 6
415611...	B10-M: 6
415636...	B10-G: 25
415761...	B10-M: 6
415895...	B10-A: 58, B10-A: 72, B10-B: 21
415896...	B10-A: 58, B10-A: 72, B10-B: 21
415898...	B10-G: 25

K

Part No.	Page
415900...	B10-B: 33, B10-G: 20
415913...	B10-G: 25
415949...	B10-L: 10
415977...	B10-L: 10
450001...	B10-A: 38
450021...	B10-A: 42
450022...	B10-A: 42
450023...	B10-A: 42, B10-A: 43
450024...	B10-A: 43
450026...	B10-A: 40
450027...	B10-A: 40
450028...	B10-A: 40
450038...	B10-A: 40
450039...	B10-A: 40
450040...	B10-A: 42
450041...	B10-A: 42, B10-A: 43
450125...	B10-A: 43
450129...	B10-A: 17
450130...	B10-A: 17
450132...	B10-A: 17
450133...	B10-A: 17
450134...	B10-A: 17
450135...	B10-A: 17
450136...	B10-A: 17
450137...	B10-A: 13, B10-A: 16, B10-A: 44, B10-A: 46
464003...	B10-B: 5
464004...	B10-B: 5
464005...	B10-B: 5
464006...	B10-B: 6
464007...	B10-B: 6
464008...	B10-B: 6
464009...	B10-B: 6
464010...	B10-B: 6
464035...	B10-B: 12
464036...	B10-B: 13
464037...	B10-B: 13
464038...	B10-B: 13
464039...	B10-B: 13
464040...	B10-B: 13

L

Part No.	Page
501001...	B10-A: 62
501004...	B10-A: 62
501005...	B10-A: 62
501016...	B10-A: 58, B10-A: 72, B10-B: 21
501019...	B10-A: 62
501050...	B10-A: 63
501051...	B10-A: 63
501052...	B10-A: 67
501053...	B10-A: 67
501054...	B10-A: 13, B10-A: 44, B10-A: 68
501055...	B10-A: 13, B10-A: 44, B10-A: 68
501056...	B10-A: 13, B10-A: 44, B10-A: 68
501058...	B10-A: 44, B10-A: 68
501059...	B10-A: 44, B10-A: 68
501060...	B10-A: 67
501061...	B10-A: 67
501064...	B10-A: 16, B10-A: 46, B10-A: 70
501065...	B10-A: 16, B10-A: 46, B10-A: 70
501066...	B10-A: 46, B10-A: 70
501067...	B10-A: 46, B10-A: 70
501157...	B10-A: 68
502001...	B10-A: 64
502002...	B10-A: 64
502003...	B10-A: 64
502004...	B10-A: 64
502005...	B10-A: 64
502012...	B10-A: 64
502013...	B10-A: 64
502014...	B10-A: 64
502015...	B10-A: 64
502016...	B10-A: 64
502023...	B10-A: 65
502024...	B10-A: 65
502025...	B10-A: 65
502026...	B10-A: 65
502027...	B10-A: 65
502034...	B10-A: 65
502035...	B10-A: 65
502036...	B10-A: 65
502037...	B10-A: 65
502038...	B10-A: 65
502045...	B10-A: 66
502046...	B10-A: 11, B10-A: 66
502047...	B10-A: 11, B10-A: 66
502048...	B10-A: 11, B10-A: 66
502049...	B10-A: 11, B10-A: 66
502050...	B10-A: 11, B10-A: 66
502051...	B10-A: 11, B10-A: 66
502052...	B10-A: 11
502053...	B10-A: 11
502054...	B10-A: 11
502055...	B10-A: 11
502056...	B10-A: 11
502057...	B10-A: 11
502058...	B10-A: 67
502059...	B10-A: 67
502060...	B10-A: 67
502061...	B10-A: 67
502062...	B10-A: 66
502064...	B10-A: 13, B10-A: 44, B10-A: 68
502066...	B10-A: 64
502068...	B10-A: 64
502069...	B10-A: 13, B10-A: 44, B10-A: 68
502070...	B10-A: 64

M

Part No.	Page
502071...	B10-A: 64
502072...	B10-A: 64
502073...	B10-A: 64
502074...	B10-A: 64
502075...	B10-A: 64
502076...	B10-A: 64
502077...	B10-A: 64
502078...	B10-A: 64
502079...	B10-A: 64
502080...	B10-A: 69, B10-A: 71
502081...	B10-A: 69, B10-A: 71
502082...	B10-A: 16, B10-A: 46, B10-A: 70
502088...	B10-A: 65
502089...	B10-A: 65
502090...	B10-A: 65
502091...	B10-A: 65
502092...	B10-A: 65
502093...	B10-A: 65
502094...	B10-A: 65
502095...	B10-A: 65
502096...	B10-A: 65
502097...	B10-A: 65
502165...	B10-A: 13, B10-A: 44, B10-A: 68
502180...	B10-A: 71
502183...	B10-A: 16, B10-A: 46, B10-A: 70
510001...	B10-A: 52
510114...	B10-A: 58
514003...	B10-A: 10, B10-A: 55
514004...	B10-A: 10, B10-A: 55
514005...	B10-A: 10
514006...	B10-A: 10
514007...	B10-A: 10
514008...	B10-A: 10
514009...	B10-A: 10
514010...	B10-A: 10
514011...	B10-A: 10
514012...	B10-A: 10
514015...	B10-A: 10, B10-A: 56
514016...	B10-A: 56
514017...	B10-A: 10
514019...	B10-A: 10
514021...	B10-A: 10
514023...	B10-A: 10
514025...	B10-A: 10
514027...	B10-A: 10
514029...	B10-A: 11
514030...	B10-A: 11
514031...	B10-A: 11
514032...	B10-A: 10, B10-A: 55
514033...	B10-A: 10, B10-A: 55
514034...	B10-A: 10, B10-A: 56
514035...	B10-A: 10, B10-A: 56
514201...	B10-A: 57

Part No.	Page
514202...	B10-A: 57
514203...	B10-A: 57
515166...	B10-A: 35
515178...	B10-B: 15, B10-B: 21
515286...	B10-A: 58
515491...	B10-A: 18, B10-B: 8, B10-B: 33, B10-G: 21
515535...	B10-I: 9
515595...	B10-B: 26
515596...	B10-B: 26
515675...	B10-I: 9
515676...	B10-I: 9
515677...	B10-I: 9
515678...	B10-I: 9
519002...	B10-E: 5
519003...	B10-E: 5
519004...	B10-E: 5
519005...	B10-E: 5
519006...	B10-E: 5
536001...	B10-A: 5
536002...	B10-A: 4
536005...	B10-A: 18
536015...	B10-A: 4, B10-A: 20, B10-A: 21, B10-A: 22, B10-A: 23, B10-B: 4, B10-B: 5, B10-B: 6, B10-B: 31, B10-G: 11, B10-L: 2
536016...	B10-A: 4, B10-A: 18, B10-A: 20, B10-A: 21, B10-A: 22, B10-A: 23, B10-B: 4, B10-B: 5, B10-B: 6, B10-B: 8, B10-B: 31, B10-B: 33, B10-G: 11, B10-G: 21, B10-L: 2, B10-L: 5
536017...	B10-L: 2
536018...	B10-L: 2
537051...	B10-B: 30, B10-G: 10
537052...	B10-B: 31, B10-G: 11
537055...	B10-G: 20
564034...	B10-B: 18
564045...	B10-B: 19
564046...	B10-B: 19
564047...	B10-B: 19
564048...	B10-B: 19
564049...	B10-B: 19
K	
K15282...	B10-I: 37
K15283...	B10-I: 37
K15284...	B10-I: 37
K15285...	B10-I: 37
K15286...	B10-I: 37
K16414...	B10-I: 36
K16415...	B10-I: 36

Part No.	Page
K16416...	B10-I: 36
K16417...	B10-I: 36
K16418...	B10-I: 36
K16419...	B10-I: 37
K16420...	B10-I: 37
K16421...	B10-I: 38
K16422...	B10-I: 38
K16423...	B10-I: 38
K16424...	B10-I: 38
K17847...	B10-I: 36
K18454...	B10-I: 36
K18455...	B10-I: 36
K18456...	B10-I: 37
K18457...	B10-I: 37
K22434...	B10-I: 38
K22436...	B10-I: 38
K22437...	B10-I: 38
K22438...	B10-I: 38
K22439...	B10-I: 36
K22440...	B10-I: 36
K23259...	B10-I: 36
K24276...	B10-I: 35
K24277...	B10-I: 35
K24278...	B10-I: 35
K24279...	B10-I: 35
K24280...	B10-I: 35
K24358...	B10-I: 35
K24391...	B10-I: 35
K31372...	B10-C: 6
K31373...	B10-C: 6
K31374...	B10-C: 6
K31375...	B10-C: 6
K31376...	B10-C: 6
K31377...	B10-C: 6
K31403...	B10-C: 6
K31404...	B10-C: 6
K31405...	B10-C: 6
K31406...	B10-C: 6
K31407...	B10-C: 6
K31408...	B10-C: 6
K31628...	B10-C: 6
K31630...	B10-C: 6
K31632...	B10-C: 6
K31634...	B10-C: 6
K32616...	B10-C: 6
K32618...	B10-C: 6
KW9208...	B10-J: 7
KW9209...	B10-J: 12
KW31562...	B10-M: 4
O	
OP-05T308...	B10-D: 21

A

B

C

D

E

F

G

H

I

J

K

L

M

INDEX

A

Interactive Experience

B

Visit our digital platform.

C

- Explore various locations and zones to see real people in real positions
- See our training and engineering departments
- Get a glimpse of our state-of-the-art logistical and machining equipment
- Virtually meet our customer service and marketing teams
- Access digital resources like literature, videos, and online tools and training

D



E

experience.alliedmachine.com

F



ToolMD[®]

Increase the production and success of your applications today.

G

- Direct access to 2D drawings and 3D models
- Assemble and view tool images in your browser
- Download drawings for use in most machining software programs
- Browse products, search item numbers, and save assemblies for future use

H

I

toolmd.com

J

WOHLHAUPTER Boring Insert Selector

Find the best insert for your application.

- Generate the correct boring insert for your job in just six easy steps
- Choose type, shape, substrate, insert form, nose radius, and material
- Order easily by adding the item to your cart

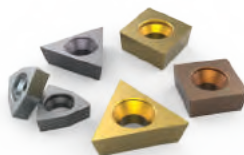

M

alliedmachine.com/bis

Insta-Code®

Eliminate the wait. Get your program now.

- Choose the best thread mill for your application
- Create program code for your machine
- Available as a PC download app (that can be used offline)
- Website app available 24/7



Insta-Code also has a **Cycle Time Calculator**

alliedmachine.com/InstaCode

Insta-Quote®

Design your custom tooling and receive a drawing and quote...all within minutes.

- Design and quote your own tooling
- Generate the solution you need in just a few steps
- Features the following products:
 - T-A® Inserts
 - T-A® Holders
 - GEN3SYS® XT Holders
 - ALVAN® Reamers

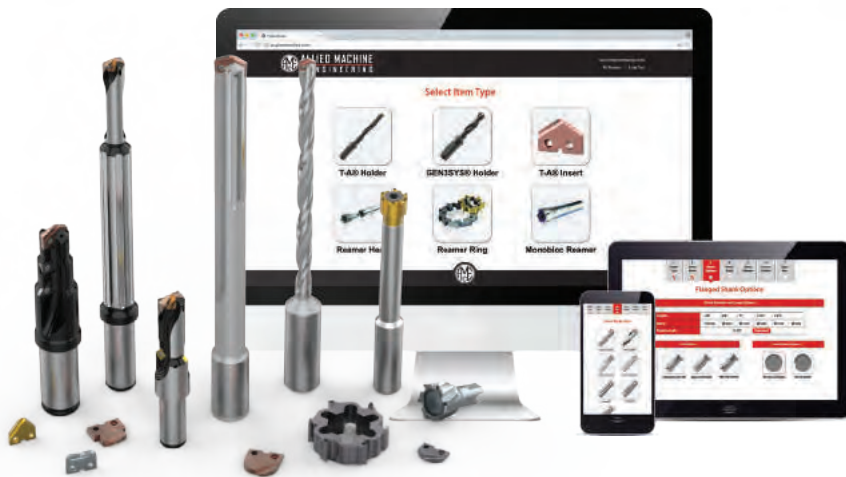

iq.alliedmachine.com

Solution Hub App

All Allied all the time.

- Quickly look up product information
- Links to our free online tools
- Locate distributors
- Stay up to date on news and events

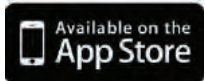

Machinist Tool App

Quickly convert cutting tool parameters for the machine inputs you need.

- Input data to calculate the RPM and speed and feed rates
- Also features the Boring Insert Selector
- Access product literature right at your fingertips

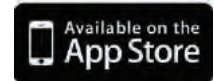

Customer Support

A
B
C
D
E
F
G
H
I
J
K
L
M
INDEX

Support You Can Count On

Allied Machine has many lines of support to ensure we're available to assist you at all times. It's important to establish relationships with new customers, but we also know it's equally important to strengthen and support relationships with existing customers. Whether you need help with an order or you need someone to come assist you at the spindle, we have the right people to get you what you need.



1

Internal Sales Support

Our inside sales team is trained to handle your account information and general inquiries. We are happy to assist you and find the answers to your questions.

 +44 (0)1384 400900 opt. 3

 sales.eu@alliedmachine.com

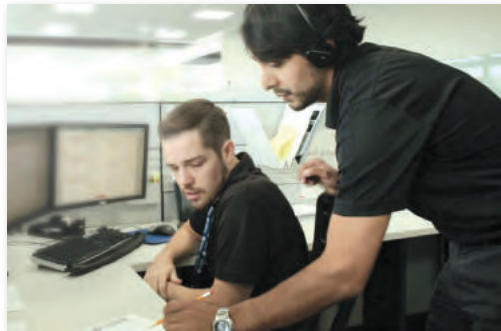

2

Engineering Support

Our highly trained and skilled Application Engineers are here to assist you. If you are experiencing technical difficulties, our engineers will recommend the best solutions to the problem. Speeds and feeds, coolant pressure, and other machining components all affect the performance of our tooling. Our Application Engineers (AEs) are experienced in working with difficult materials in many different environments. Give us a call and put our knowledge to the test.

 +44 (0)1384 400900 opt. 4

 engineering.eu@alliedmachine.com

3

Field Support

Allied Machine provides local engineering support all over the world. Our Field Sales Engineers (FSEs) spend months training in-house before going to the field. This support line allows us to provide assistance to our customers right at the spindle. They are available to visit your facility, run demos and tests, and work hand-in-hand with machine operators and engineers to find the best possible tooling solutions.

Visit www.alliedmachine.com/field-lookup to find your Regional Sales Manager.

 +44 (0)1384 400900 opt. 4

 engineering.eu@alliedmachine.com



Online Training

Get *all* the tooling training of our 2-day in-person Technical Education Seminar (TES) through the online **Allied Tool Academy** training platform. Level up your tooling IQ through a series of product overviews, demos, and short quizzes.

- Online TES Certification as well as other training modules
- On demand
- On YOUR schedule

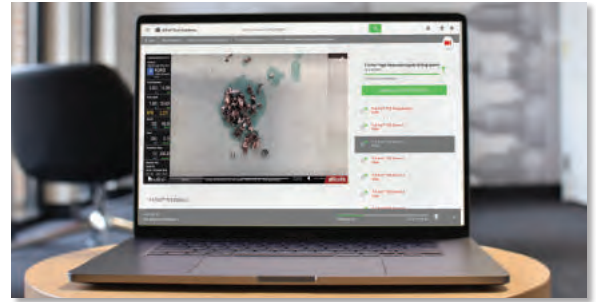

Register online today:
www.alliedtoolacademy.com



Register online today:
www.alliedmachine.com/live

Allied LIVE (Broadcasting)

Join us for **LIVE broadcast** training events where you will have the ability to learn about our tooling, watch live demos, and ask our trainers questions.

- Online
- Quick brief presentation provides basic knowledge of our products
- Watch live demos of tools at the spindle at different speeds and feeds



On-site Technical Education Seminar (TES)

Allied Machine's **Technical Education Seminar (TES)** puts the attendees in front of the machines. When you attend our two day TES program, you'll gain first-hand experience in *real-life* application situations. Test and experiment with different speeds and feeds, observe the results, and discover the best solution.

- Training Lab: In-depth training at the spindle allows you to choose speeds and feeds
- Learning Lab: Quick, brief sessions provide basic knowledge of our products

 Register online today:
www.alliedmachine.com/TES



Guaranteed Test / Demo Application Form

Distributor PO #	
------------------	--

The following must be filled out completely before your test will be considered

IMPORTANT: For processing, send Purchase Order to your Allied Field Sales Engineer (FSE). Please clearly mark the paperwork as "Test Order."

Distributor Information

Company Name: _____
 Contact: _____
 Account Number: _____
 Phone: _____
 Email: _____

End User Information

Company Name: _____
 Contact: _____
 Industry: _____
 Phone: _____
 Email: _____

Current Process List all tooling, coatings, substrates, speeds and feeds, tool life, and any problems you are experiencing

Test Objective List what would make this a successful test (i.e. penetration rate, finish, tool life, hole size, etc.)

Application Information

Hole Diameter: _____ in/mm	Tolerance: _____	Material: _____ (4150 / A36 / Cast Iron / etc.)
Pre-existing Diameter: _____ in/mm	Depth of Cut: _____ in/mm	Hardness: _____ (BHN / Rc)
Required Finish: _____ RMS		State: _____ (Casting / Hot rolled / Forging)

Machine Information

Machine Type: _____ (Lathe / Screw machine / Machine center / etc.)	Builder: _____ (Haas, Mori Seiki, etc.)	Model #: _____
Shank Required: _____ (CAT50 / Morse taper, etc.)		Power: _____ HP/KW
Rigidity: _____ <input type="checkbox"/> Excellent <input type="checkbox"/> Good <input type="checkbox"/> Poor	Orientation: _____ <input type="checkbox"/> Vertical <input type="checkbox"/> Horizontal	Tool Rotating: _____ <input type="checkbox"/> Yes <input type="checkbox"/> No
		Thrust: _____ lbs/N

Coolant Information

Coolant Delivery: _____ (Through tool / Flood)	Coolant Pressure: _____ PSI / bar
Coolant Type: _____ (Air mist, oil, synthetic, water soluble, etc.)	Coolant Volume: _____ GPM / LPM

Requested Tooling

QTY	Item Number

QTY	Item Number

engineering.eu@alliedmachine.com

Allied Machine & Engineering Co. (Europe) Ltd
 93 Vantage Point, Pensnett Estate,
 Kingswinford, DY6 7FR, United Kingdom

+44 (0)1384 400 900
www.alliedmachine.com



ALLIED MACHINE & ENGINEERING



WOHLHAUPTER
 Holmaking Solutions for Today's Manufacturing

Warranty Information



Allied Machine & Engineering ("Allied Machine") warrants to original equipment manufacturers, distributors, industrial and commercial users of its products for one year from the original date of sale that each new product manufactured or supplied by Allied Machine shall be free from defects in material and workmanship.

Allied Machine's sole and exclusive obligation under this warranty is limited to, at its option, without additional charge, replacing or repairing this product or issuing a credit. For this warranty to be applied, the product must be returned freight prepaid to the plant designated by an Allied Machine representative and which, upon inspection, is determined by Allied Machine to be defective in material and workmanship.

Complete information as to operating conditions, machine, setup, and the application of cutting fluid should accompany any product returned for inspection. This warranty shall not apply to any Allied Machine products which have been subjected to misuse, abuse, improper operating conditions, improper machine setup or improper application of cutting fluid or which have been repaired or altered if such repair or alteration, in the judgement of Allied Machine, would adversely affect the performance of the product.

THIS WARRANTY IS IN LIEU OF ALL OTHER WARRANTIES, EXPRESS OR IMPLIED, INCLUDING ANY IMPLIED WARRANTY OF MERCHANTABILITY OR FITNESS FOR A PARTICULAR PURPOSE. Allied Machine shall have no liability or responsibility for any claim, whether in contract, tort or otherwise, for any loss or damage arising out of, connected with, or resulting from the manufacture, sale, delivery or use of any product sold hereunder, in excess of the cost of replacement or repair as provided herein.

Allied Machine shall not be liable in contract or in tort (including, without limitation, negligence, strict liability or otherwise) for economic losses of any kind or for any special, incidental, indirect, consequential, punitive or exemplary damages arising in any way out of the performance of, or failure to perform this agreement.

ALL PRICES, DELIVERIES, DESIGNS, AND MATERIALS ARE SUBJECT TO CHANGE WITHOUT NOTICE.



Allied Machine & Engineering Co. Europe Ltd. is registered to ISO 9001:2015 by bsi.



Allied Machine & Engineering is registered to ISO 9001:2015 by DQS



Wohlhaupter GmbH is registered to ISO 9001:2015 by QA TECHNICH

Europe

Allied Machine & Engineering Co. (Europe) Ltd.

93 Vantage Point
Pensnett Estate
Kingswinford
West Midlands
DY6 7FR England

Phone:

+44 (0) 1384.400900

Wohlhaupter GmbH

Maybachstrasse 4
Postfach 1264
72636 Frickenhausen
Germany

Phone:

+49 (0) 7022.408.0

Fax:

+49 (0) 7022.408.212

United States

Allied Machine & Engineering

120 Deeds Drive
Dover OH 44622
United States

Phone:

+1.330.343.4283

Fax:

+1.330.602.3400

Toll Free USA and Canada:

800.321.5537

Toll Free USA and Canada:

800.223.5140

Allied Machine & Engineering

485 W Third Street
Dover OH 44622
United States

Phone:

+1.330.343.4283

Fax:

+1.330.364.7666
(Engineering Dept.)

Toll Free USA and Canada:

800.321.5537

Asia

Wohlhaupter India Pvt. Ltd.

B-23, 3rd Floor
B Block Community Centre
Janakpuri, New Delhi - 110058
India

Phone:

+91 (0) 11.41827044

Your local Allied Machine representative:

FEBAMETAL

Febametal S.p.A.

Via Grandi 15, Grugliasco (TO) 10095

011-7701412

febametal@febametal.com

www.febametal.com

www.alliedmachine.com

Allied Machine & Engineering Co. (Europe) Ltd is registered to **ISO 9001:2015** by bsi.

Allied Machine & Engineering is registered to **ISO 9001:2015** by DQS

Wohlhaupter GmbH is registered to **ISO 9001:2015** by QTA TECHNIC

 **ALLIED MACHINE
& ENGINEERING**

WOHLHAUPTER

Holemaking Solutions for Today's Manufacturing